

Construction

Horizontal multi-stage close coupled pumps in **chrome-nickel stainless steel**.

Compact and robust construction, without protruding flange and with single-piece lantern bracket and base.

Single-piece barrel casing, with front suction port above pumps axis and radial delivery at top.

Filling and draining plugs on the middle of the pump, accessible from any side (like the terminal box).

Applications

For water supply.

For clean liquids, without abrasives, which are non-aggressive for stainless steel (with suitable seal materials, on request).

Universal pump, for domestic use, for civil and industrial applications, for garden use and irrigation.

Operating conditions

Liquid temperature from - 15 °C to + 110 °C.

Ambient temperature up to 40 °C.

Maximum permissible pressure in the pump casing: 8 bar.

Continuous duty.

Motor

2-pole induction motor, 50 Hz (n ≈ 2800 rpm).

MXH: three-phase 230/400 V ± 10% up to 3 kW;
400/690 V ± 10% from 3,7 to 4 kW.

MXHM: single-phase 230 V ± 10%, with thermal protector.
Capacitor inside the terminal box.

Insulation class F. Protection IP 54.

Motor suitable for operation with frequency converter from 1,8 kW.

Classification scheme IE2 for three-phase motors from 0,75 kW.

Constructed in accordance with: EN 60034-1; EN 60034-30.

EN 60335-1, EN 60335-2-41.

Special features on request

- Other voltages.
- Frequency 60 Hz (as per 60 Hz data sheet).
- Protection IP 55.
- Special mechanical seal
- Pump casing seal rings in FPM.
- Higher or lower liquid or ambient temperatures.
- Motor suitable for operation with frequency converter up to 1,5 kW.

Materials

Component	Material
Pump casing	Chrome-nickel steel 1.4301 EN 10088 (AISI 304)
Stage casing	Chrome-nickel steel 1.4301 EN 10088 (AISI 304)
Wear ring	PTFE
Impeller	Chrome-nickel steel 1.4301 EN 10088 (AISI 304)
Casing cover	Chrome-nickel steel 1.4301 EN 10088 (AISI 304)
Spacer sleeve	Chrome-nickel steel 1.4301 EN 10088 (AISI 304)
Pump shaft	Chrome-nickel steel 1.4305 EN 10088 (AISI 303)
Plug	Chrome-nickel steel 1.4305 EN 10088 (AISI 303)
Mechanical seal with seat according to ISO 3069	Ceramic alumina, carbon, EPDM (Other materials on request)

Coverage chart n ≈ 2800 rpm

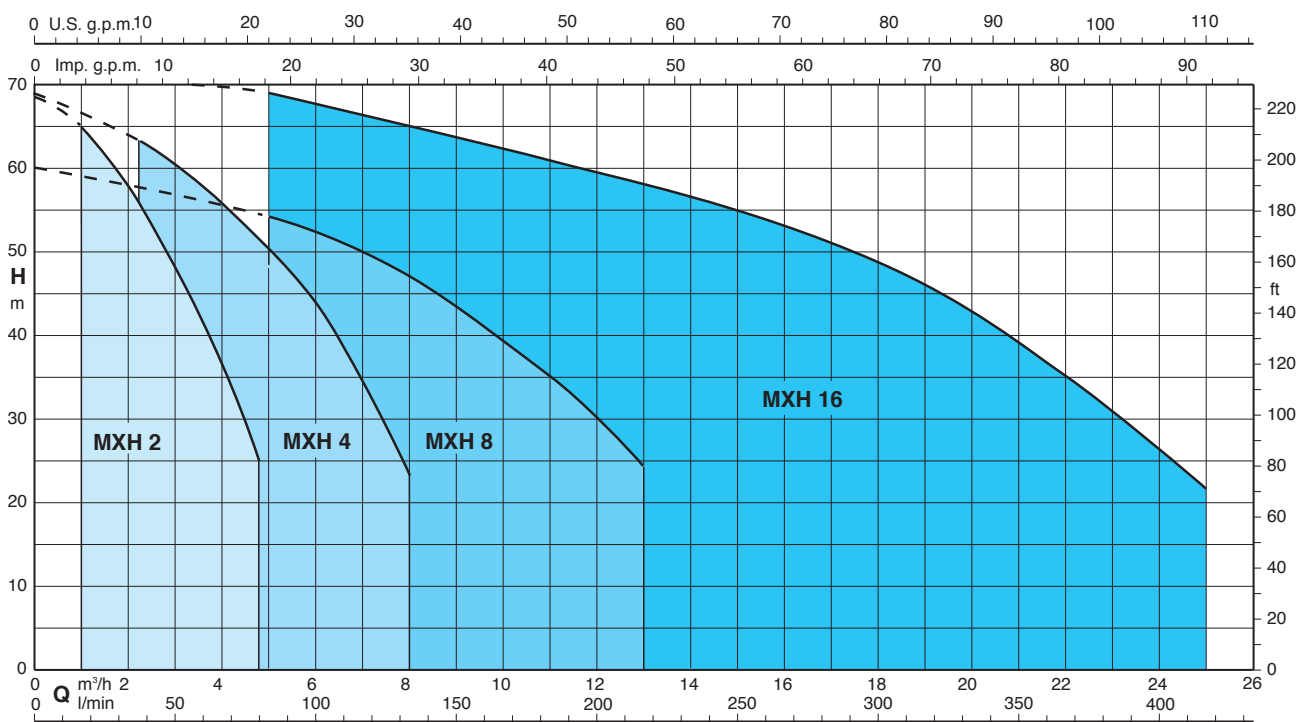

Performance n ≈ 2800 rpm

3 ~	230 V		400 V		1 ~	230 V		P ₁		P ₂		Q										
	A	A	A	A		kW	kW	HP	kW	HP	m ³ /h		l/min	0	1	1,5	2	2,5	3	3,5	4	4,25
MXH 202E	1,7	1	MXHM 202E	2,3	0,5	0,33	0,45	H m	22	20,5	19,4	18	16,4	14,2	12	9,9	8,7	5,5				
MXH 203E	2,4	1,4	MXHM 203E	3	0,65	0,45	0,6		33	31	29	27	24,5	21,7	18,6	15,5	13,8	9				
MXH 204/A	2,8	1,6	MXHM 204/A	4,2	0,9	0,55	0,75		45	42,5	40,4	37,5	34,5	30,8	26,7	22,4	20,1	14,8				
MXH 205/A	3,5	2	MXHM 205/A	5,4	1,2	0,75	1		57	53,5	50,5	47,5	43,5	39	34	28,5	25,8	19				
MXH 206/B	4,7	2,7	MXHM 206	7,4	1,5	1,1	1,5		68,5	65	61,5	58	53,5	48	43	36,5	33,5	25				

3 ~	230 V		400 V		1 ~	230 V		P ₁		P ₂		Q										
	A	A	A	A		kW	kW	HP	kW	HP	m ³ /h		l/min	0	2,25	3	3,5	4	4,5	5	6	7
MXH 402E	2,4	1,4	MXHM 402E	3	0,65	0,45	0,6	H m	22,5	20	19	18,5	17,5	16	15	12,5	9,5	6				
MXH 403/A	2,8	1,6	MXHM 403/A	4,2	0,9	0,55	0,75		33	30	29	27,5	26	24,5	23	19,5	15	9,5				
MXH 404/A	3,5	2	MXHM 404/A	5,4	1,2	0,75	1		44,5	40,5	38	36,5	35	33	31	26	20	12,5				
MXH 405/B	4,7	2,7	MXHM 405	7,4	1,5	1,1	1,5		56,5	52	50	47,5	45,5	43	40	33,5	26	16,5				
MXH 406	6,2	3,6	MXHM 406	9,2	2	1,5	2		68,5	63	60	58	56	53,5	51	44	35	23				

3 ~	230 V		400 V		1 ~	230 V		P ₁		P ₂		Q										
	A	A	A	A		kW	kW	HP	kW	HP	m ³ /h		l/min	0	5	6	7	8	9	10	11	12
MXH 802/A	3,5	2	MXHM 802/A	5,4	1,2	0,75	1	H m	22,5	20,5	20	19	18	16,5	15	13	11	8,5				
MXH 803	5	2,9	MXHM 803	7,4	1,5	1,1	1,5		36	32	30,5	29	27,5	25,5	23	20	17	14				
MXH 804	6,2	3,6	MXHM 804	9,2	2	1,5	2		48	42,5	41	39	37	34,5	32	28	24	19,5				
MXH 805/A	7,5	4,3	MXHM 805	11,2	2,5	1,8	2,5		60	54	52	49,5	47	43,5	39,5	35	29,5	24				

3 ~	230 V		400 V		P ₂		Q										
	A	A	kW	HP	m ³ /h	l/min		0	5	8	11	14	16	18	20	22	25
MXH 1602	6,2	3,6	1,5	2	H m	24	23	21,7	20,5	18,8	17,5	15,8	14	11,5	6,5		
MXH 1603/A	7,5	4,3	1,8	2,5		36	34	31,8	29,5	26,8	24,8	22,4	19,2	15,3	8,8		
MXH 1604/A	11,5	6,6	3	4		48	46,5	44,5	41,5	38	36	33	29	23	14		
MXH 1605/A	9,6	5,5	3,7	5		60	57,5	55	51,5	48	45	42	37,5	31,5	19		
MXH 1606/A	9,6	5,5	4	5,5		71	68	65	61	56	53	49	44	36	22		

P₁ Max. power input.
P₂ Rated motor power output.

Test results with clean cold water, without gas content.
Tolerances according to UNI EN ISO 9906:2012

+ 0,5 m security margin on NPSH-value is necessary.

Dimensions and weights

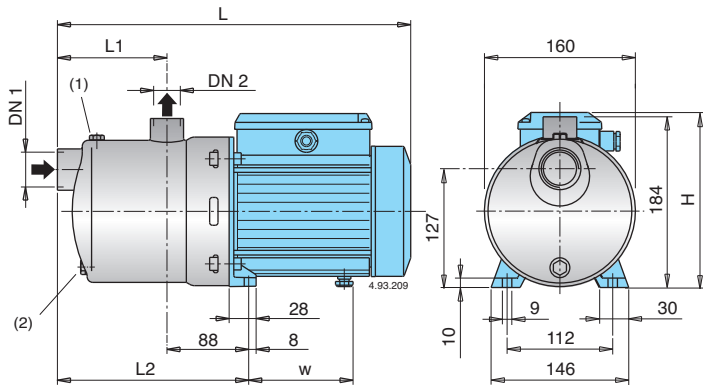

TYPE	DN1 ISO 228	DN2 ISO 228	mm							kg	
			L	L1	L2	H	w	MXH	MXHM		
MXH 202E - MXHM 202E	G 1 1/4	G 1	331	94	182	176	98,5	6,8	6,9		
MXH 203E - MXHM 203E	G 1 1/4	G 1	331	94	182	176	98,5	7,6	7,7		
MXH 204/A - MXHM 204/A	G 1 1/4	G 1	381	118	206	193	112	10	11		
MXH 205/A - MXHM 205/A	G 1 1/4	G 1	405	142	230	193	112	11,5	12,5		
MXH 402E - MXHM 402E	G 1 1/4	G 1	331	94	182	176	98,5	7,6	7,7		
MXH 403/A - MXHM 403/A	G 1 1/4	G 1	357	94	182	193	112	9,3	10,3		
MXH 404/A - MXHM 404/A	G 1 1/4	G 1	381	118	206	193	112	10,8	11,8		
MXH 802/A - MXHM 802/A	G 1 1/2	G 1	381	118	206	193	112	10,6	11,6		

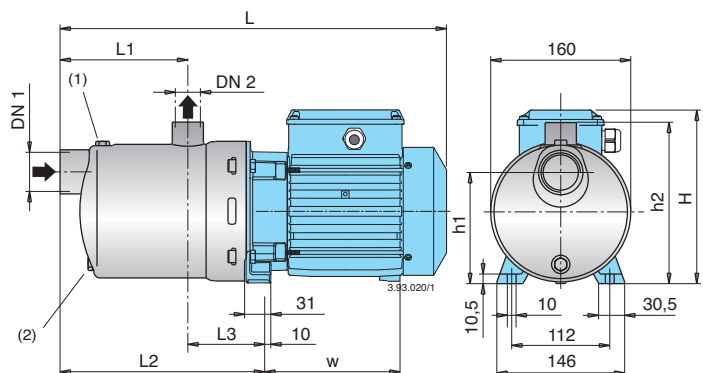

TYPE	DN1 ISO 228	DN2 ISO 228	mm										kg	
			L	L1	L2	L3	H	h1	h2	w	MXH	MXHM		
MXH 206/B - MXHM 206	G 1 1/4	G 1	500	166	254	88	210	127	184	167	18,5	18,6		
MXH 405/B - MXHM 405	G 1 1/4	G 1	476	142	230	88	210	127	184	167	18	18		
MXH 406 - MXHM 406	G 1 1/4	G 1	500	166	254	88	210	127	184	167	19,5	20,5		
MXH 803 - MXHM 803	G 1 1/2	G 1	452	118	206	88	210	127	184	167	15,8	16,9		
MXH 804 - MXHM 804	G 1 1/2	G 1	482	148	236	88	210	127	184	167	18,2	19,2		
MXH 805/A - MXHM 805	G 1 1/2	G 1	552	178	266	88	210	127	184	207	21,4	22,4		
MXH 1602	G 2	G 1 1/2	476	128	230	101	210	117	187	167	18,2	-		
MXH 1603/A	G 2	G 1 1/2	516	128	230	101	210	117	187	207	20,8	-		
MXH 1604/A	G 2	G 1 1/2	612	166	279	113	235	132	202	232	33,8	-		
MXH 1605/A	G 2	G 1 1/2	650	203	316	113	235	132	202	232	35,5	-		
MXH 1606/A	G 2	G 1 1/2	687	241	354	113	235	132	202	232	36,4	-		

(1) Filling (2) Draining

Characteristic curves $n \approx 2800$ rpm

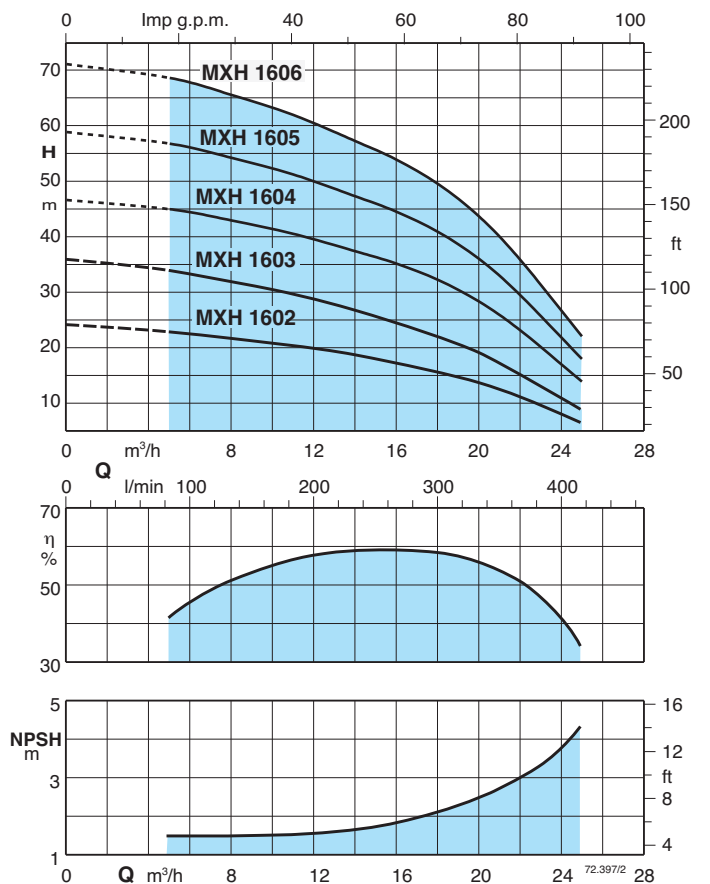
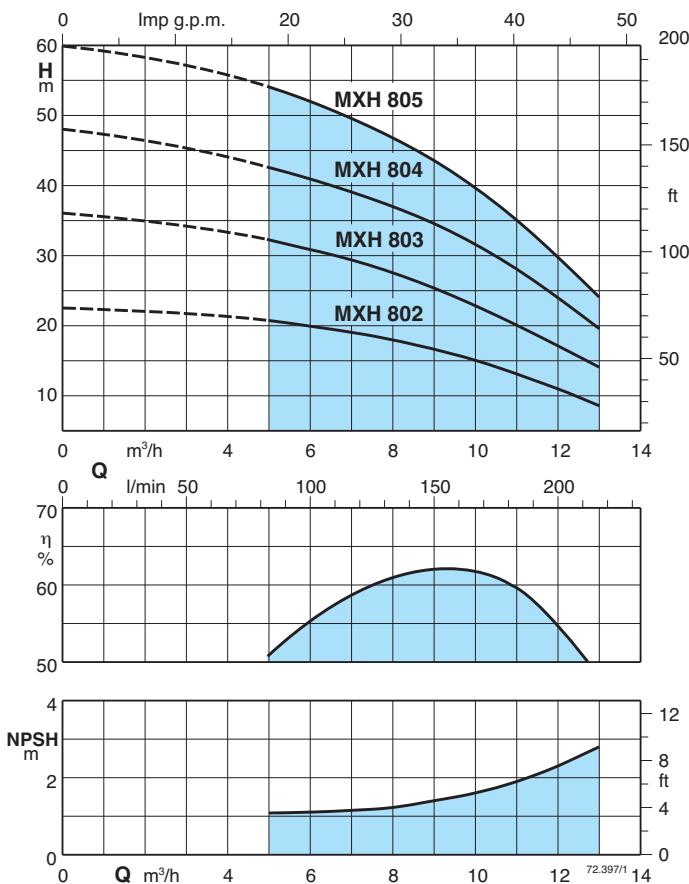
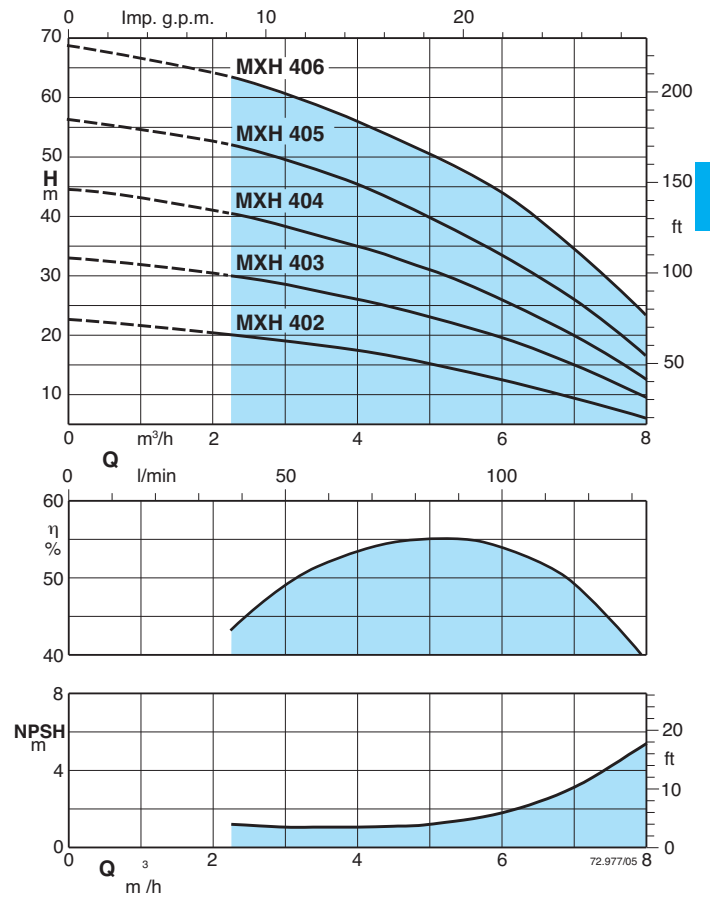
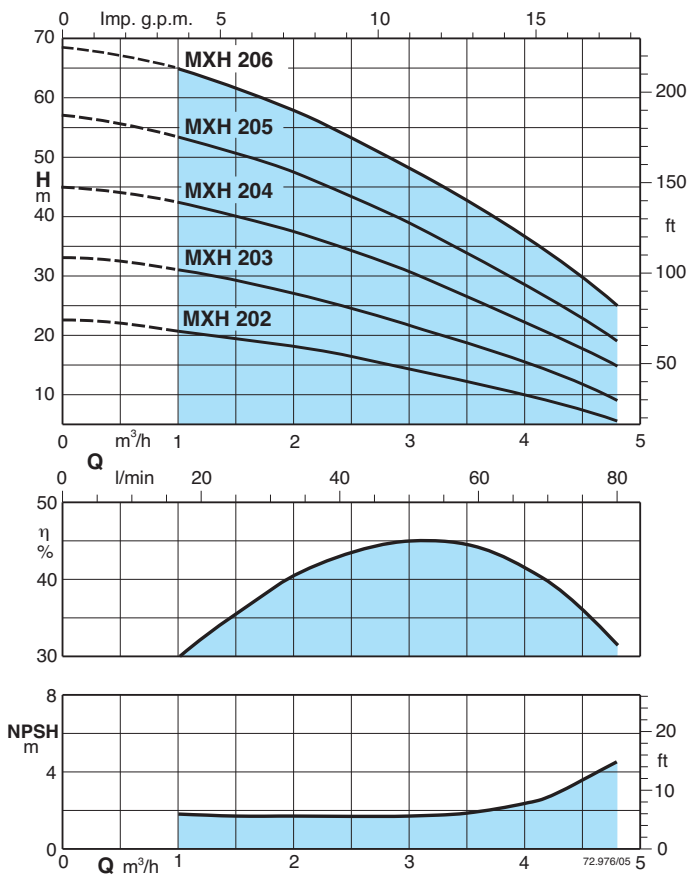

Features

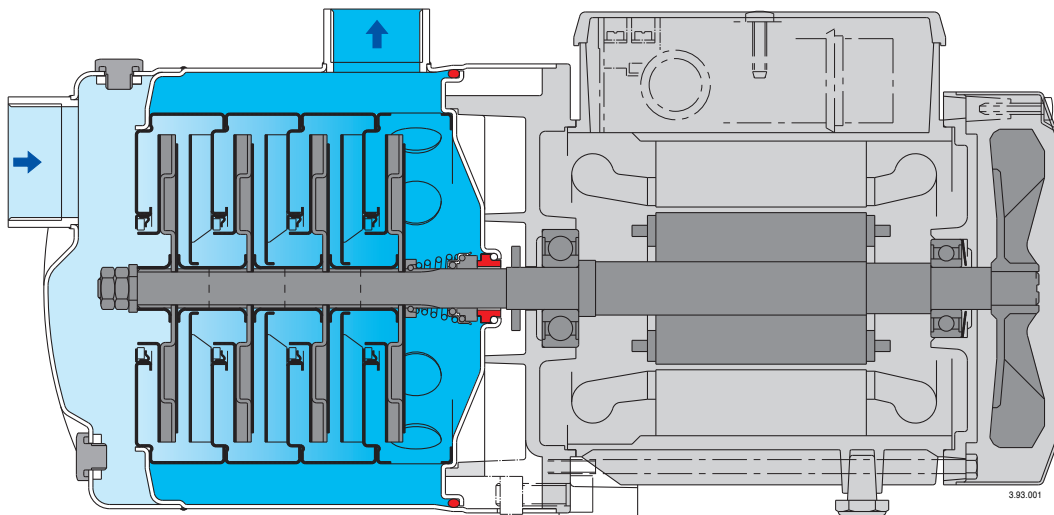

Extra safety

against running dry, with the suction port above pump axis.

Reliable

All hydraulic parts in contact with the pumped liquid are of stainless steel.
For liquids from -15 °C to 110 °C.

Robust

Single-piece, thick barrel casing.

Compact

Single-piece lantern bracket and base.
Without protruding flange.

Greater protection

against leakage, with the pump casing cover separated from the motor shield.
Possibility of inspecting the seal through the side apertures between the two walls.
Greater protection against water entering the motor from outside provided by an extension of the pump casing around the lantern bracket.



Construction

Horizontal multi-stage close coupled pumps in **chrome-nickel-molybdenum stainless steel AISI 316L**. Compact and robust construction, without protruding flange and with single-piece lantern bracket and base. Single-piece barrel casing, with front suction port above pumps axis and radial delivery at top. Filling and draining plugs on the middle of the pump, accessible from any side (like the terminal box).

Applications

For water supply. For clean liquids, without abrasives, which are non-aggressive for stainless steel (with suitable seal materials, on request). Universal pump, for domestic use, for civil and industrial applications, for garden use and irrigation.

Operating conditions

Liquid temperature from - 15 °C to + 110 °C.
Ambient temperature up to 40 °C.
Maximum permissible pressure in the pump casing: 8 bar.
Continuous duty.

Motor

2-pole induction motor, 50 Hz ($n \approx 2800$ rpm).
MXHL: three-phase 230/400 V $\pm 10\%$.
MXHLM: single-phase 230 V $\pm 10\%$, with thermal protector. Capacitor inside the terminal box.
Insulation class F. Protection IP 54.
Motor suitable for operation with frequency converter from 1,8 kW.
Classification scheme IE2 for three-phase motors from 0,75 kW.
Constructed in accordance with: EN 60034-1; EN 60034-30.
EN 60335-1, EN 60335-2-41.

Materials

Component	Material
Pump casing	Cr-Ni-Mo steel 1.4404 EN 10088 (AISI 316L)
Stage casing	Cr-Ni-Mo steel 1.4404 EN 10088 (AISI 316L)
Wear ring	PTFE
Impeller	Cr-Ni-Mo steel 1.4404 EN 10088 (AISI 316L)
Casing cover	Cr-Ni-Mo steel 1.4404 EN 10088 (AISI 316L)
Spacer sleeve	Cr-Ni-Mo steel 1.4404 EN 10088 (AISI 316L)
Pump shaft	Cr-Ni-Mo steel 1.4404 EN 10088 (AISI 316L)
Plug	Cr-Ni-Mo steel 1.4404 EN 10088 (AISI 316L)
Mechanical seal with seat according to ISO 3069	Ceramic alumina, carbon, EPDM (Other materials on request)

Special features on request

- Other voltages.
- Frequency 60 Hz (as per 60 Hz data sheet).
- Protection IP 55.
- Special mechanical seal
- Pump casing seal rings in FPM.
- Higher or lower liquid or ambient temperatures.
- Motor suitable for operation with frequency converter up to 1,5 kW.

Coverage chart $n \approx 2800$ rpm

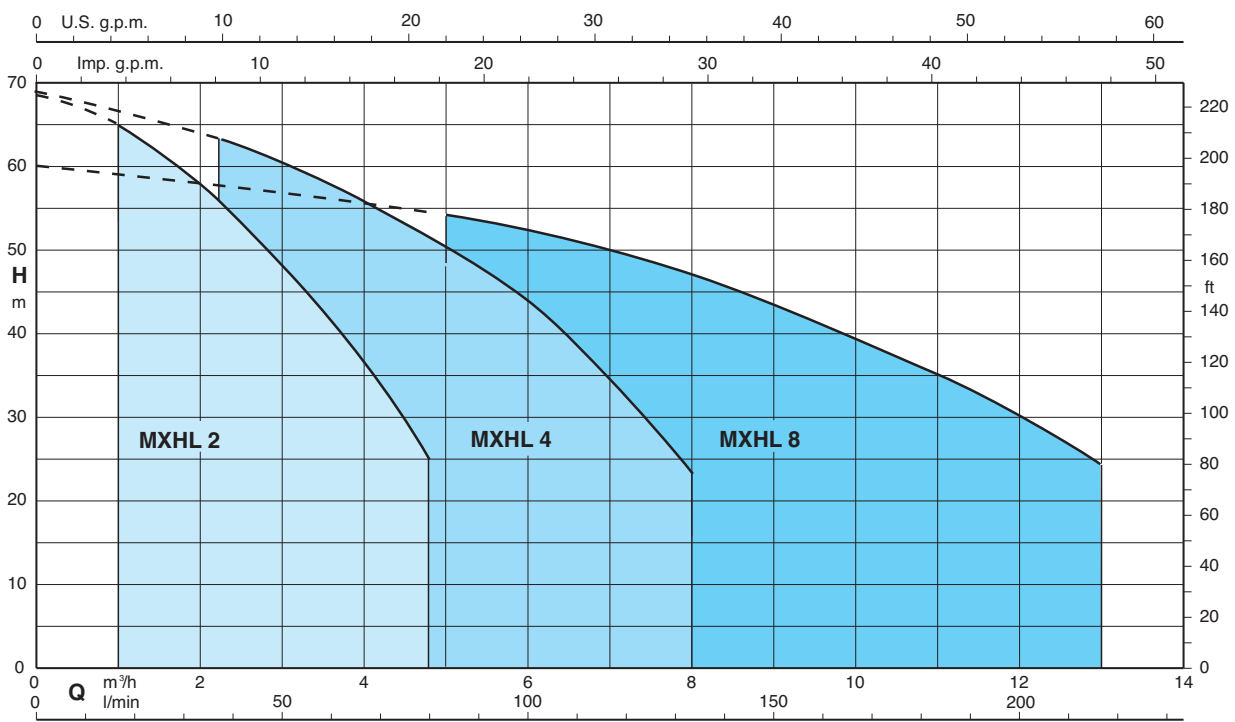

Performance n ≈ 2800 rpm

	3 ~ 230 V 400 V		1 ~ 230 V		P ₁		P ₂		Q	m ³ /h									
	A	A	A	kW	kW	HP	l/min	0		1	1,5	2	2,5	3	3,5	4	4,25	4,8	
MXHL 202E	1,7	1	MXHLM 202E	2,3	0,5	0,33	0,45	H m	22	20,5	19,4	18	16,4	14,2	12	9,9	8,7	5,5	
MXHL 203E	2,4	1,4	MXHLM 203E	3	0,65	0,45	0,6		33	31	29	27	24,5	21,7	18,6	15,5	13,8	9	
MXHL 204/A	2,8	1,6	MXHLM 204/A	4,2	0,9	0,55	0,75		45	42,5	40,4	37,5	34,5	30,8	26,7	22,4	20,1	14,8	
MXHL 205/A	3,5	2	MXHLM 205/A	5,4	1,2	0,75	1		57	53,5	50,5	47,5	43,5	39	34	28,5	25,8	19	
MXHL 206/B	4,7	2,7	MXHLM 206	7,4	1,5	1,1	1,5		68,5	65	61,5	58	53,5	48	43	36,5	33,5	25	

	3 ~ 230 V 400 V		1 ~ 230 V		P ₁		P ₂		Q	m ³ /h									
	A	A	A	kW	kW	HP	l/min	0		2,25	3	3,5	4	4,5	5	6	7	8	
MXHL 402E	2,4	1,4	MXHLM 402E	3	0,65	0,45	0,6	H m	22,5	20	19	18,5	17,5	16	15	12,5	9,5	6	
MXHL 403/A	2,8	1,6	MXHLM 403/A	4,2	0,9	0,55	0,75		33	30	29	27,5	26	24,5	23	19,5	15	9,5	
MXHL 404/A	3,5	2	MXHLM 404/A	5,4	1,2	0,75	1		44,5	40,5	38	36,5	35	33	31	26	20	12,5	
MXHL 405/B	4,7	2,7	MXHLM 405	7,4	1,5	1,1	1,5		56,5	52	50	47,5	45,5	43	40	33,5	26	16,5	
MXHL 406	6,2	3,6	MXHLM 406	9,2	2	1,5	2		68,5	63	60	58	56	53,5	51	44	35	23	

	3 ~ 230 V 400 V		1 ~ 230 V		P ₁		P ₂		Q	m ³ /h										
	A	A	A	kW	kW	HP	l/min	0		5	6	7	8	9	10	11	12	13		
MXHL 802/A	3,5	2	MXHLM 802/A	5,4	1,2	0,75	1	H m	22,5	20,5	20	19	18	16,5	15	13	11	8,5		
MXHL 803	5	2,9	MXHLM 803	7,4	1,5	1,1	1,5		36	32	30,5	29	27,5	25,5	23	20	17	14		
MXHL 804	6,2	3,6	MXHLM 804	9,2	2	1,5	2		48	42,5	41	39	37	34,5	32	28	24	19,5		
MXHL 805/A	7,5	4,3	MXHLM 805	11,2	2,5	1,8	2,5		60	54	52	49,5	47	43,5	39,5	35	29,5	24		

P₁ Max. power input.

P₂ Rated motor power output.

Test results with clean cold water, without gas content.
Tolerances according to UNI EN ISO 9906:2012

+ 0,5 m security margin on NPSH-value is necessary.

Dimensions and weights

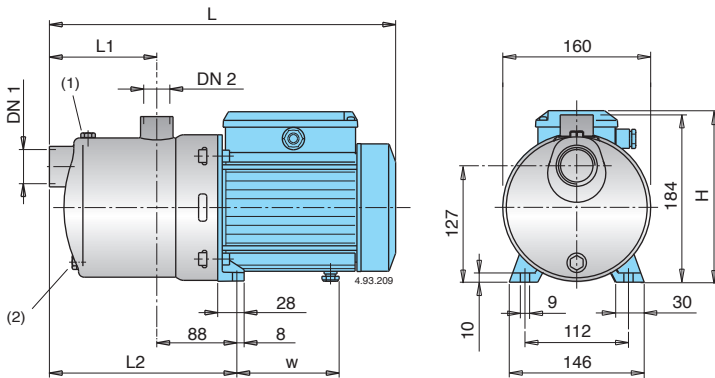

TYPE	DN1	DN2	mm					kg	
			L	L1	L2	H	w	MXHL	MXHLM
MXHL 202E - MXHLM 202E	G 1 1/4	G 1	331	94	182	176	98,5	6,8	6,9
MXHL 203E - MXHLM 203E	G 1 1/4	G 1	331	94	182	176	98,5	7,6	7,7
MXHL 204/A - MXHLM 204/A	G 1 1/4	G 1	381	118	206	193	112	10	11
MXHL 205/A - MXHLM 205/A	G 1 1/4	G 1	405	142	230	193	112	11,5	12,5
MXHL 402E - MXHLM 402E	G 1 1/4	G 1	331	94	182	176	98,5	7,6	7,7
MXHL 403/A - MXHLM 403/A	G 1 1/4	G 1	357	94	182	193	112	9,3	10,3
MXHL 404/A - MXHLM 404/A	G 1 1/4	G 1	381	118	206	193	112	10,8	11,8
MXHL 802/A - MXHLM 802/A	G 1 1/2	G 1	381	118	206	193	112	10,6	11,6

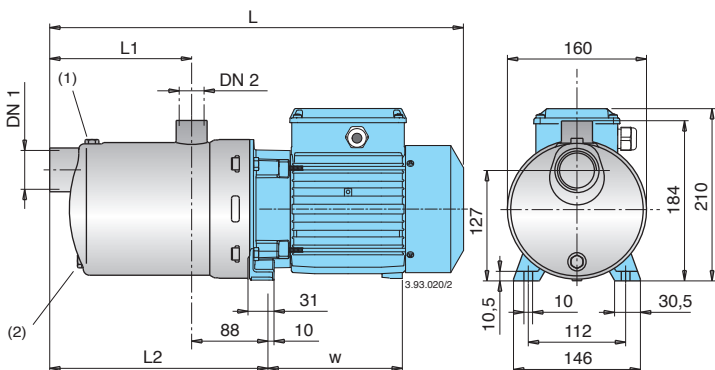

TYPE	DN1	DN2	mm				kg	
			L	L1	L2	w	MXHL	MXHLM
MXHL 206/B - MXHLM 206	G 1 1/4	G 1	500	166	254	167	18,5	18,6
MXHL 405/B - MXHLM 405	G 1 1/4	G 1	476	142	230	167	18	18
MXHL 406 - MXHLM 406	G 1 1/4	G 1	500	166	254	167	19,5	20,5
MXHL 803 - MXHLM 803	G 1 1/2	G 1	452	118	206	167	15,8	16,9
MXHL 804 - MXHLM 804	G 1 1/2	G 1	482	148	236	167	18,2	19,2
MXHL 805/A - MXHLM 805	G 1 1/2	G 1	552	178	266	207	21,4	22,4

(1) Filling (2) Draining

Characteristic curves $n \approx 2800$ rpm

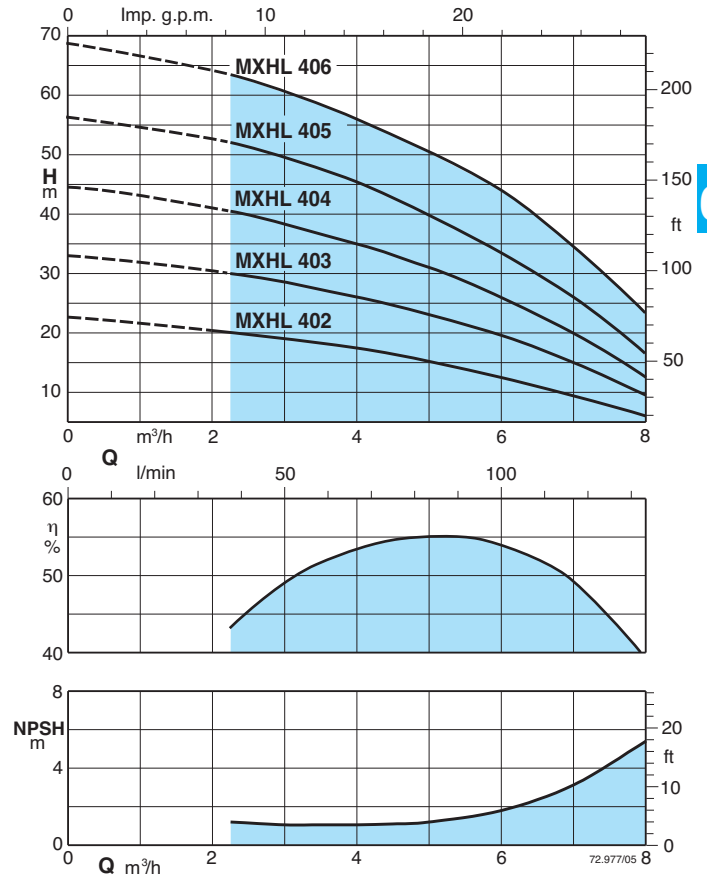
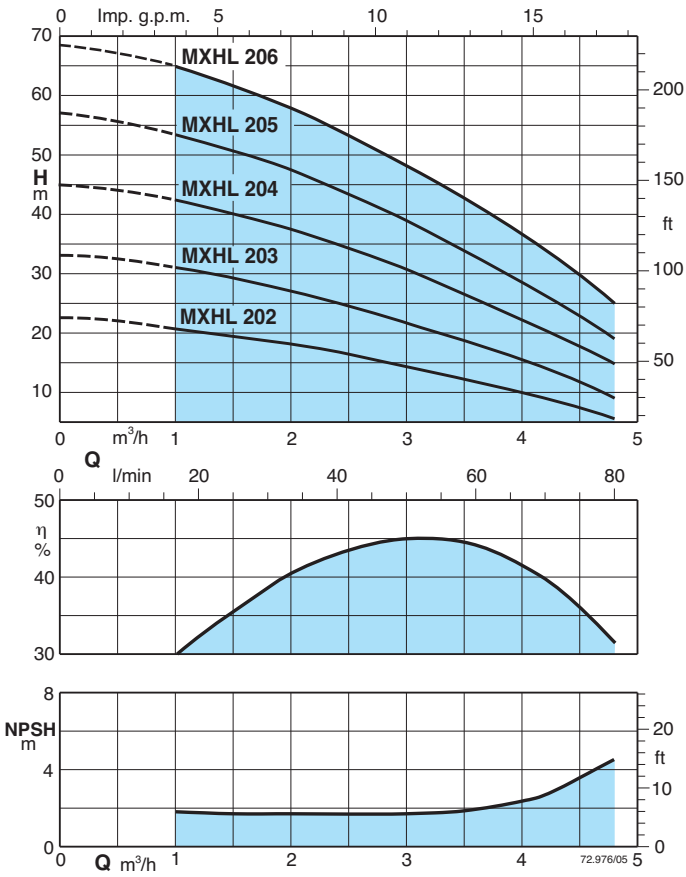

6.1

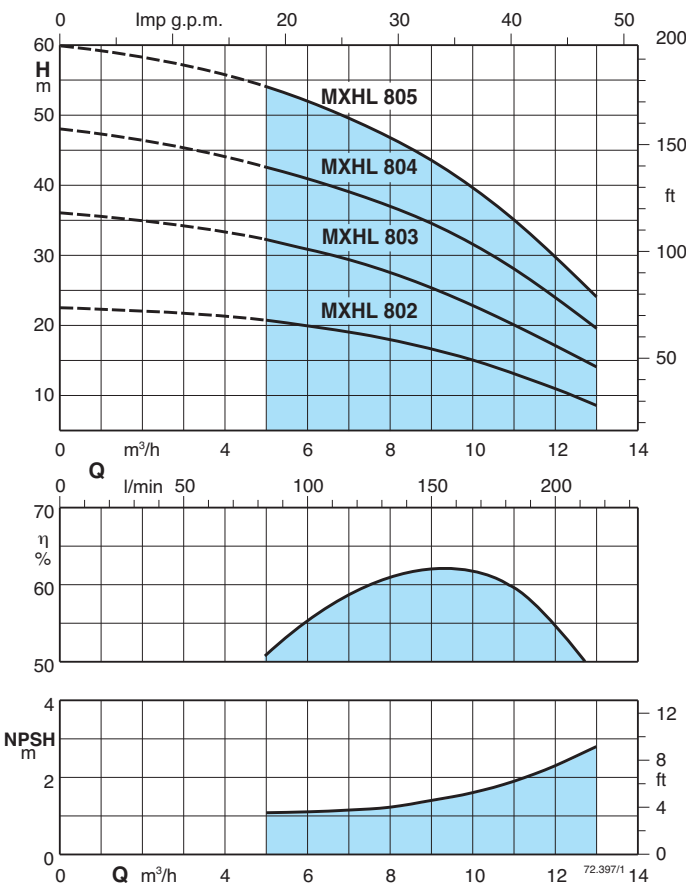

Features

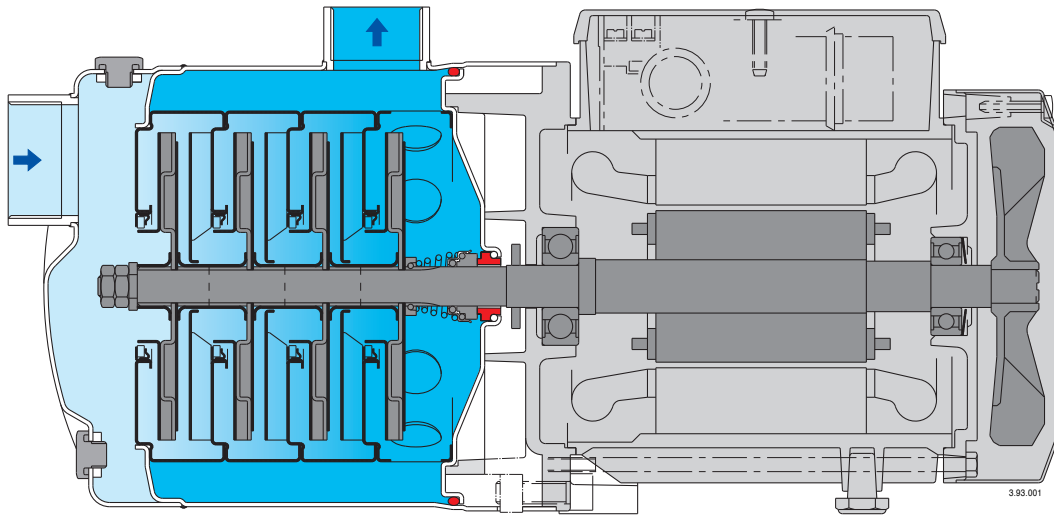

Extra safety

against running dry, with the suction port above pump axis.

Reliable

All hydraulic parts in contact with the pumped liquid are of stainless steel.
For liquids from -15 °C to 110 °C.

Robust

Single-piece, thick barrel casing.

Compact

Single-piece lantern bracket and base.
Without protruding flange.

Greater protection

against leakage, with the pump casing cover separated from the motor shield.
Possibility of inspecting the seal through the side apertures between the two walls.
Greater protection against water entering the motor from outside provided by an extension of the pump casing around the lantern bracket.

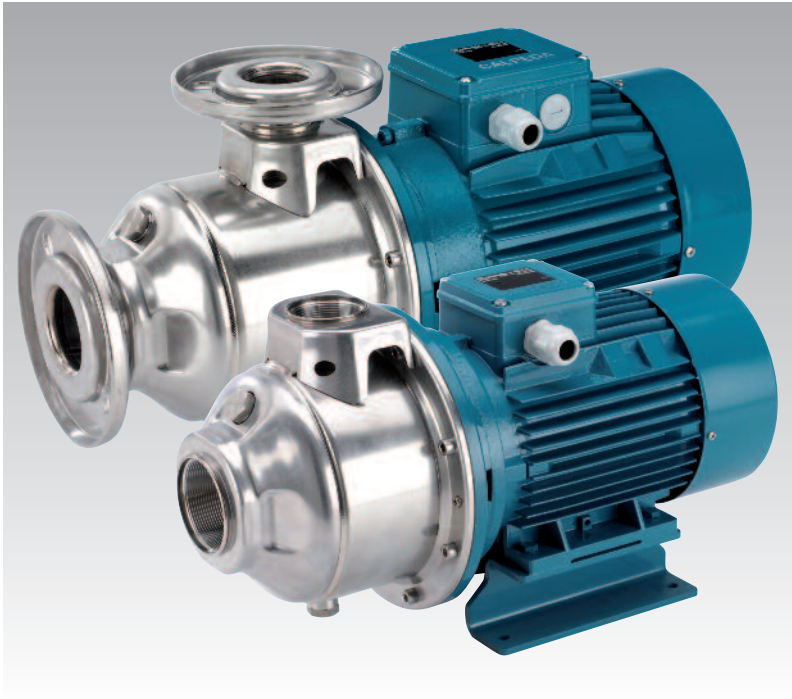

Construction

Horizontal multi-stage close coupled pumps in **chrome-nickel stainless steel**.
 Compact and robust construction, with compact lantern bracket and motor with feet.
 Single-piece barrel casing, with front suction port above pumps axis and radial delivery at top.
 Filling and draining plugs on the middle of the pump, accessible from any side (like the terminal box).

Applications

For water supply.
 For clean liquids, without abrasives, which are non-aggressive for stainless steel (with suitable seal materials, on request).
 Universal pump, for civil and industrial applications, for garden use and irrigation.

Operating conditions

Liquid temperature from - 15 °C to + 110 °C.
 Ambient temperature up to 40 °C.
 Maximum permissible pressure in the pump casing: 10 bar.

Motor

2-pole induction motor, 50 Hz ($n \approx 2900$ rpm).
MXH: three-phase 230/400 V $\pm 10\%$ up to 3 kW;
 400/690 V $\pm 10\%$ from 4 to 7,5 kW.
 Insulation class F. Protection IP 54.
 Motor suitable for operation with frequency converter.
Classification scheme IE2.
 Constructed in accordance with: EN 60034-1;
 EN 60034-30.

Materials

Component	Material
Pump casing	Chrome-nickel steel AISI 304
Stage casing	Chrome-nickel steel AISI 304
Wear ring	PTFE
Impeller	Chrome-nickel steel AISI 304
Casing cover	Chrome-nickel steel AISI 304
Spacer sleeve	Chrome-nickel steel AISI 304
Pump shaft	Chrome-nickel steel AISI 316
Plug	Chrome-nickel steel AISI 303
Mechanical seal with seat according to ISO 3069-KU	Ceramic alumina, carbon, EPDM (Other materials on request)

Special features on request

- Pump with Victaulic ports (MXH-V).
- Pump with flanged ports (MXH-F).
- Other voltages.
- Frequency 60 Hz (as per 60 Hz data sheet).
- Protection IP 55.
- Special mechanical seal
- Seal rings in FPM.
- Higher or lower ambient temperatures.
- Motor suitable operation with frequency converter.

Coverage chart $n \approx 2900$ rpm

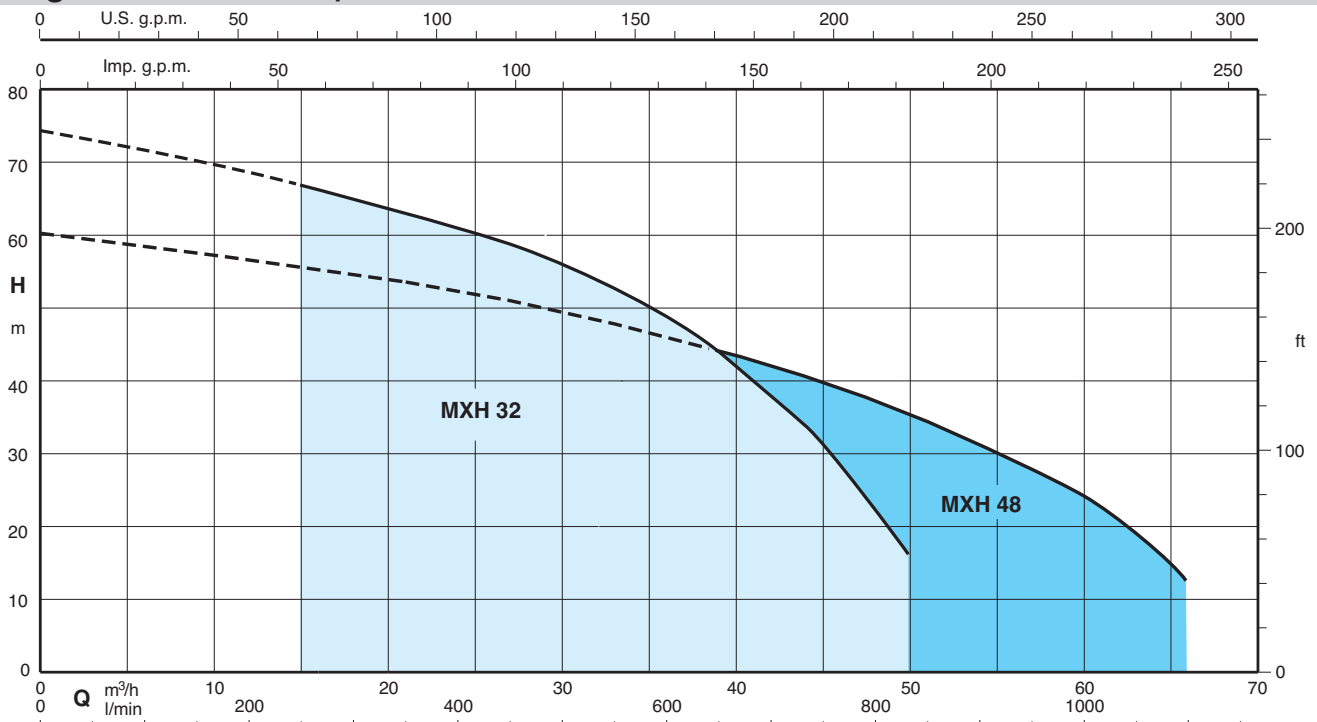

Performance $n \approx 2900$ rpm

	3 ~		P ₂		Q											
	230 V	400 V	kW	HP		m ³ /h	0	15	21	24	27	30	33	36	39	44
	A	A			l/min	0	250	350	400	450	500	550	600	650	733	833
MXH 3201/A	9,15	5,3	2,2	3	H m	18,4	16,3	15,3	14,8	14	13	12	10,8	9,3	6	-
MXH 3202/A		9,6	4	5,5		37	33	31	30	28,5	27	25	23	20,5	15	7,5
MXH 3203/A		12	5,5	7,5		55,5	50	47	45,5	43	40,5	38	35	31	23	10
MXH 3204/A		16	7,5	10		74,5	67	63	61	59	56	53	49	44	34	16,5

	3 ~		P ₂		Q											
	230 V	400 V	kW	HP		m ³ /h	0	21	27	33	39	45	48	51	54	60
	A	A			l/min	0	350	450	550	650	750	800	850	900	1000	1100
MXH 4801/A	11,5	6,6	3	4	H m	20	18	17	16	14,5	12,5	11,5	10,5	9,5	7	-
MXH 4802/A		12	5,5	7,5		41	35,3	33	30,5	27,5	24,5	22,5	21	19	14	7,5
MXH 4803/A		16	7,5	10		60,5	53	50	46	42,5	38	35	32,5	29	22,5	16

P1 Max. power input. Test results with clean cold water, without gas content.
P2 Rated motor power output. Tolerances according to UNI EN ISO 9906:2012

Characteristic curves $n \approx 2900$ rpm

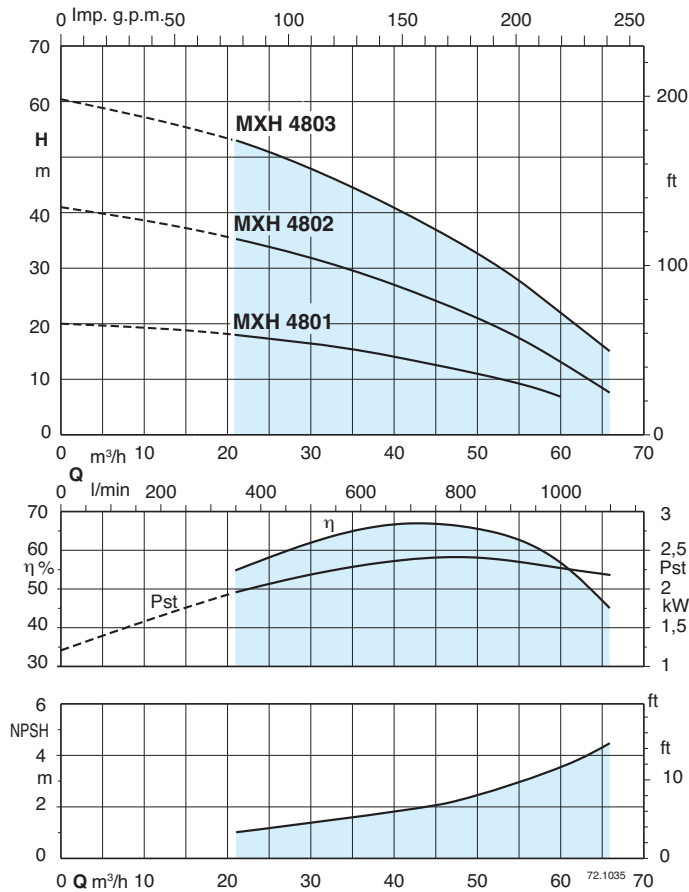
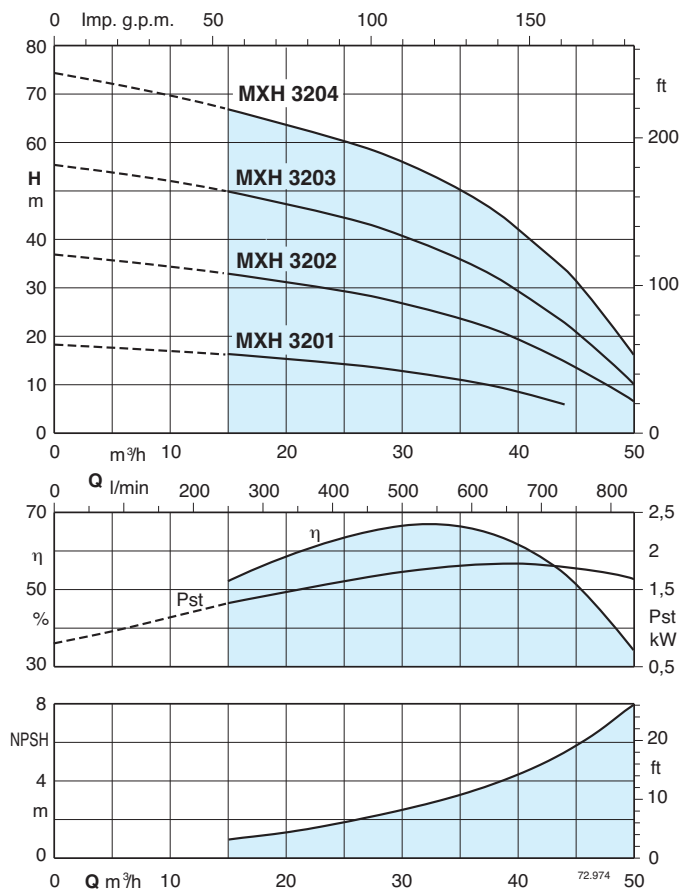

Designation

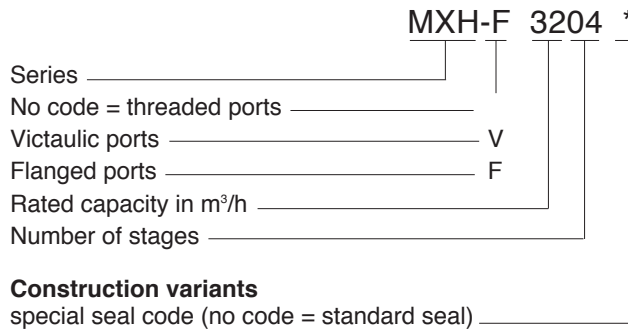

6.2

Dimensions and weights

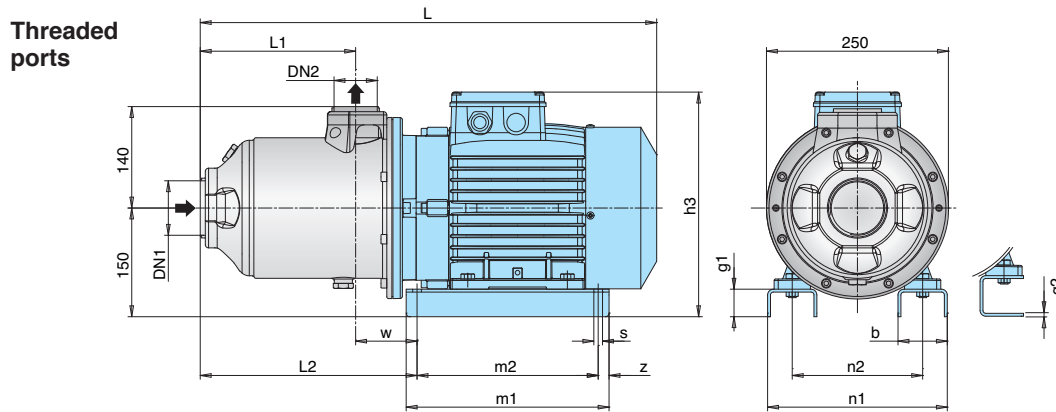

TYPE	DN1 ISO 228	DN2	mm														kg
			L	L1	L2	h3	m1	m2	n1	n2	z	b	s	w	g1	g2	
MXH 3201/A	G 2 1/2	G 2	501	120,5	216	280	205	175	170	130	15	54	10	92,5	-	6	29,4
MXH 3202/A	G 2 1/2	G 2	515	120,5	233	290	205	175	180	140	15	54	10	112	-	6	38,5
MXH 3203/A	G 2 1/2	G 2	582	166,5	251	310	280	250	258	190	15	68	12	84	38	-	50
MXH 3204/A	G 2 1/2	G 2	628	212,5	297	310	280	250	258	190	15	68	12	84	38	-	57,5
MXH 4801/A	G 3	G 2 1/2	545	136	263	290	205	175	180	140	15	54	10	128,5	-	6	38
MXH 4802/A	G 3	G 2 1/2	566	136	235	310	280	250	258	190	15	68	12	100	38	-	49,5
MXH 4803/A	G 3	G 2 1/2	628	197,5	297	310	280	250	258	190	15	68	12	100	38	-	58

Victaulic ports

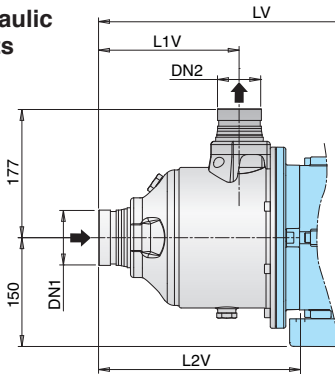

TYPE	DN1 mm	DN2 mm	mm		
			LV	L1V	L2V
MXH-V 3201/A	76,1 (DN65)	60,3 (DN50)	541	160	256
MXH-V 3202/A	76,1 (DN65)	60,3 (DN50)	555	160	273
MXH-V 3203/A	76,1 (DN65)	60,3 (DN50)	622	206	291
MXH-V 3204/A	76,1 (DN65)	60,3 (DN50)	668	252	337
MXH-V 4801/A	88,9 (DN80)	76,1 (DN65)	585	175	303
MXH-V 4802/A	88,9 (DN80)	76,1 (DN65)	606	175	275
MXH-V 4803/A	88,9 (DN80)	76,1 (DN65)	668	237	337

Flanged ports

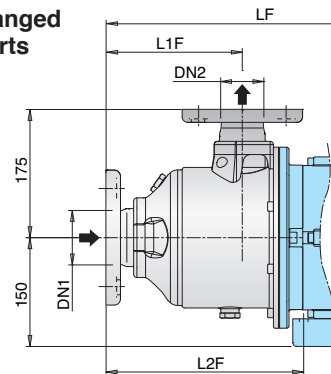

TYPE	DN1 mm	DN2 mm	mm		
			LF	L1F	L2F
MXH-F 3201/A	65	50	531	151	246
MXH-F 3202/A	65	50	545	151	263
MXH-F 3203/A	65	50	612	197	281
MXH-F 3204/A	65	50	658	243	327
MXH-F 4801/A	80	65	565	156	283
MXH-F 4802/A	80	65	586	156	255
MXH-F 4803/A	80	65	648	218	317

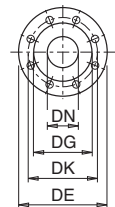

Flanges* EN 1092-2

DN	DE	DK	DG	Fori	
				N.	Ø
50	165	125	99	4	19
65	185	145	118	4	19
80	200	160	132	8	19

* ASME 150 lb (ex ANSI 150 lb)

Features

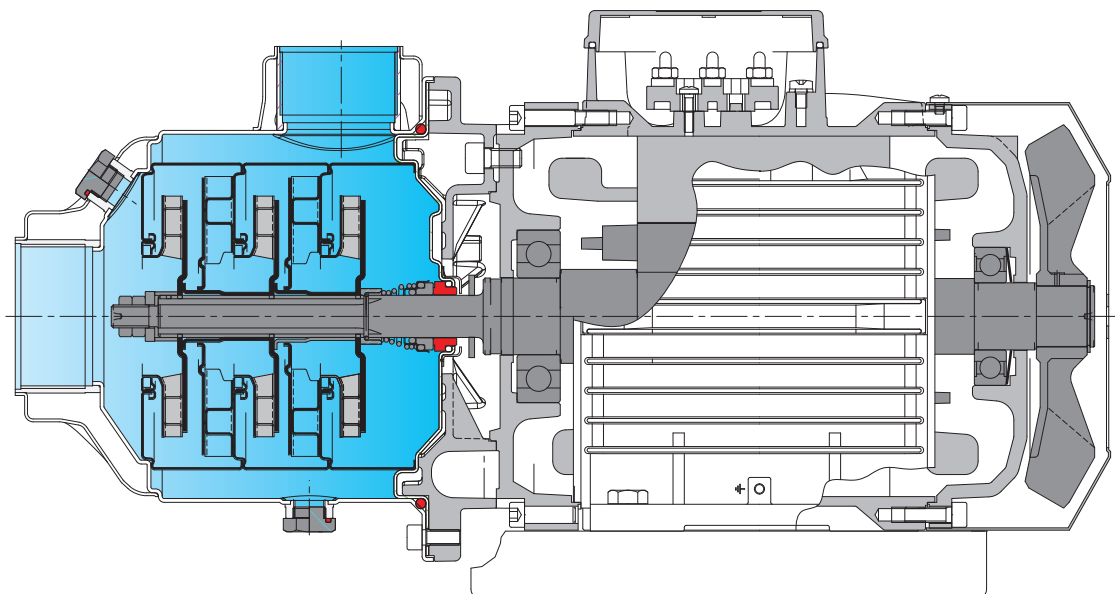

Flexibility

Three versions of ports: threaded, flanged and Victaulic.

Extra safety

With front axis suction port for optimum suction conditions.

Reliable

All hydraulic parts in contact with the pumped liquid are made in stainless steel.
For liquids from -15 °C to 110 °C.

Robust

Single-piece, thick barrel casing, open on one side only, with reinforced threaded ports.

Compact

The bracket between pump and motor is extremely compact.

Greater protection

Against leakage, with the pump casing cover separated from the motor shield.
Possibility of inspecting the seal through the side apertures between the two walls.