

Submersible DRAINAGE pumps

for clear water



PERFORMANCE RANGE

- Flow rate up to **300 l/min** (18 m³/h)
- Head up to **20 m**

APPLICATION LIMITS

- Immersion depth:
 - **1.5 m** with 5 m long power cable for RX 1-2-3
 - **5 m** with 10 m long power cable
 - **10 m** with a sufficiently long power cable
- Maximum liquid temperature **+50 °C**
(Maximum liquid temperature +90 °C for a maximum of 3 minutes intermittent service)
- Passage of suspended solids up to **Ø 10 mm**
- Suction level:
 - **14 mm** above ground level for RX 1-2-3
 - **25 mm** above ground level for RX 4-5
- Continuous service **S1**

CONSTRUCTION AND SAFETY STANDARDS

Complete with:

- **5 m** long power cable for RX1-2-3
- **10 m** long power cable for RX 4-5
- float switch for single-phase versions

EN 60335-1
IEC 60335-1
CEI 61-150

EN 60034-1
IEC 60034-1
CEI 2-3



CERTIFICATIONS



INSTALLATION AND USE

The **RX** series pumps are suitable for use with **clear water** that does not contain abrasive particles.

As a result of the design solutions that have been adopted, such as the complete cooling of the motor and the shaft with double seal, these pumps are easy to use and reliable.

They are suitable for use in fixed installations and applications such as draining small flooded areas (rooms, cellars, garages) in the event of an emergency, for the disposal of waste water in the home (from dishwashers, washing machines) and for emptying drainage traps.

PATENTS - TRADE MARKS - MODELS

- Registered Community Design n° 342159-0013 (RX 1-2-3)

OPTIONALS AVAILABLE ON REQUEST

- Special mechanical seal
- RX 1-2-3 pumps with a **10 m** long power cable.
 - ➔ N.B. Standard EN 60335-2-41 states that the power cable must be 10 m long for outdoor applications
- Single-phase pumps without float switch
- Other voltages or 60 Hz frequency

GUARANTEE

2 years subject to terms and conditions

CHARACTERISTIC CURVES AND PERFORMANCE DATA

50 Hz n= 2900 1/min

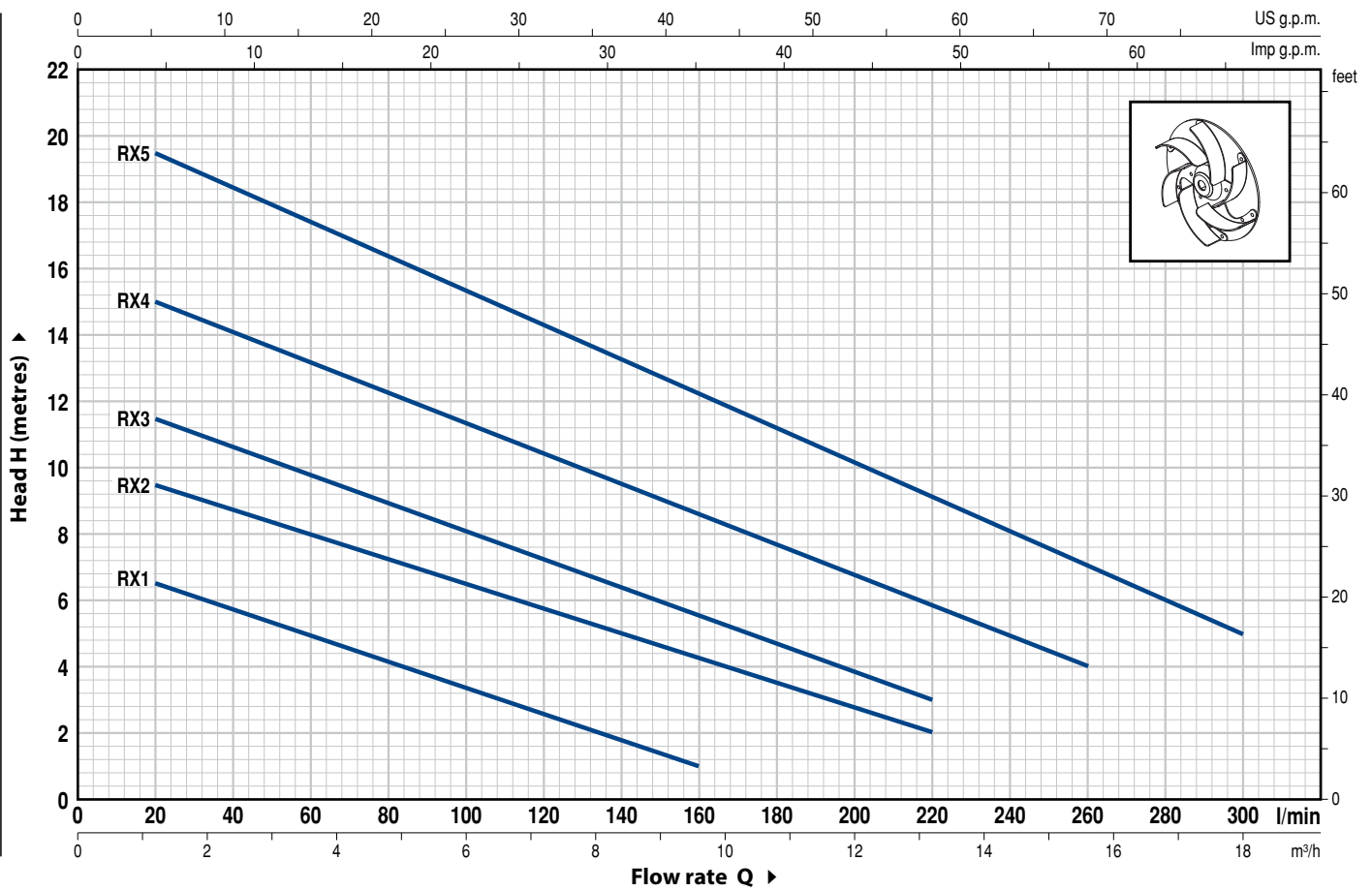

MODEL		POWER		Q	Flow rate													
Single-phase	Three-phase	kW	HP		m ³ /h	0	1.2	3.6	6.0	8.4	9.6	12.0	13.2	15.6	18.0			
				l/min	0	20	60	100	140	160	200	220	260	300				
RXm 1	-	0.25	0.33	H metres	7.5	6.5	5	3.5	2	1								
RXm 2	-	0.37	0.50		10	9.5	8	6.5	5	4.5	2.5	2						
RXm 3	-	0.55	0.75		12	11.5	9.5	8	6.5	5.5	3.5	3						
RXm 4	RX 4	0.75	1		16	15	13	11.5	9.5	8.5	6.5	5.5	4					
RXm 5	RX 5	1.1	1.5		20	19.5	17.5	15.5	13.5	12.5	10	9	7	5				

Q = Flow rate H = Total manometric head

Tolerance of characteristic curves in compliance with EN ISO 9906 Grade 3.

DIMENSIONS AND WEIGHT

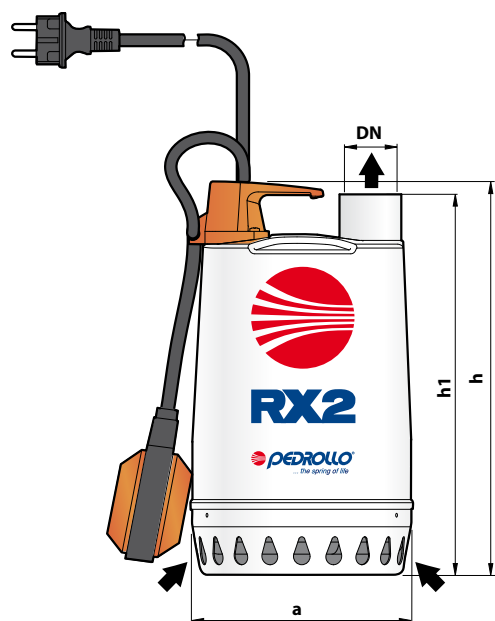

Typical installation

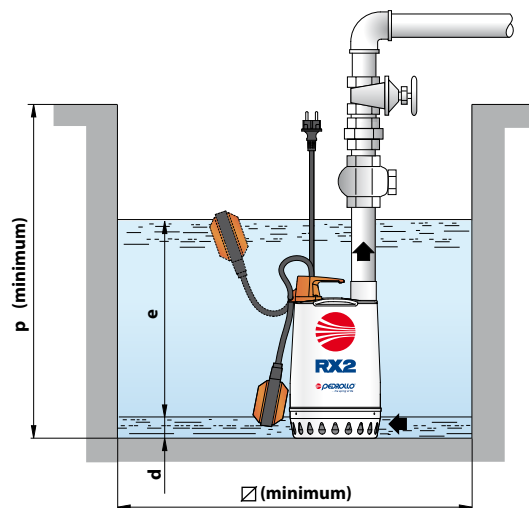

MODEL	PORT DN	DIMENSIONS mm							kg
		a	h	h1	d	e	p	Ø	
Single-phase									
RXm 1	1 1/4"	147	255	247	14	variable	350	350	4.7
RXm 2				277					5.8
RXm 3			285	277					7.4

ABSORPTION

MODEL	VOLTAGE (single-phase)		
	230 V	240 V	110 V
Single-phase			
RXm 1	1.3 A	1.3 A	3.0 A
RXm 2	2.0 A	2.0 A	5.3 A
RXm 3	3.6 A	3.6 A	7.5 A

PALLETIZATION

MODEL	GROUPAGE			CONTAINER		
	n° pumps	H (mm)	kg	n° pumps	H (mm)	kg
Single-phase						
RXm 1	96	1320	467	162	2131	776
RXm 2	96	1320	573	162	2131	955
RXm 3	96	1360	727	144	1970	1083

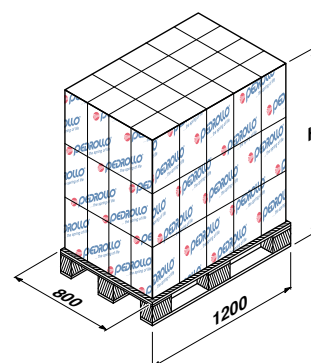

RX 4-5

POS.	COMPONENT	CONSTRUCTION CHARACTERISTICS			
1	PUMP BODY	Stainless steel AISI 304, with threaded port in compliance with ISO 228/1			
2	SUCTION FILTER	Stainless steel AISI 304			
3	SUCTION PLATE	Stainless steel AISI 304			
4	IMPELLER	Stainless steel AISI 304			
5	MOTOR CASING	Stainless steel AISI 304			
6	MOTOR CASING PLATE	Stainless steel AISI 304			
7	MOTOR SHAFT	Stainless steel EN 10088-3 - 1.4104			
8	SHAFT WITH DOUBLE MECHANICAL SEAL SEPARATED BY AN OIL CHAMBER				
	Seal	Shaft	Materials		
	<i>Model</i>	<i>Diameter</i>	<i>Stationary ring</i>	<i>Rotational ring</i>	<i>Elastomer</i>
	MG1-14D SIC	Ø 14 mm	Silicon carbide	Silicon carbide	NBR

9	BEARINGS	6203 ZZ / 6203 ZZ	
10	CAPACITOR		
	Pump	Capacitance	
	<i>Single-phase</i>	<i>(230 V or 240 V)</i>	<i>(110 V)</i>
	RXm 4	20 µF 450 VL	30 µF 250 VL
	RXm 5	25 µF 450 VL	-

11	ELECTRIC MOTOR
	- Single-phase 230 V - 50 Hz with thermal overload protector built-in to the winding
	- Three-phase 400 V - 50 Hz
	- Insulation: F class
	- Protection: IP X8

12	POWER CABLE
	10 metre long "H07 RN-F" cable (with Schuko plug on single-phase versions only)

13	FLOAT SWITCH
	(only for single-phase versions)

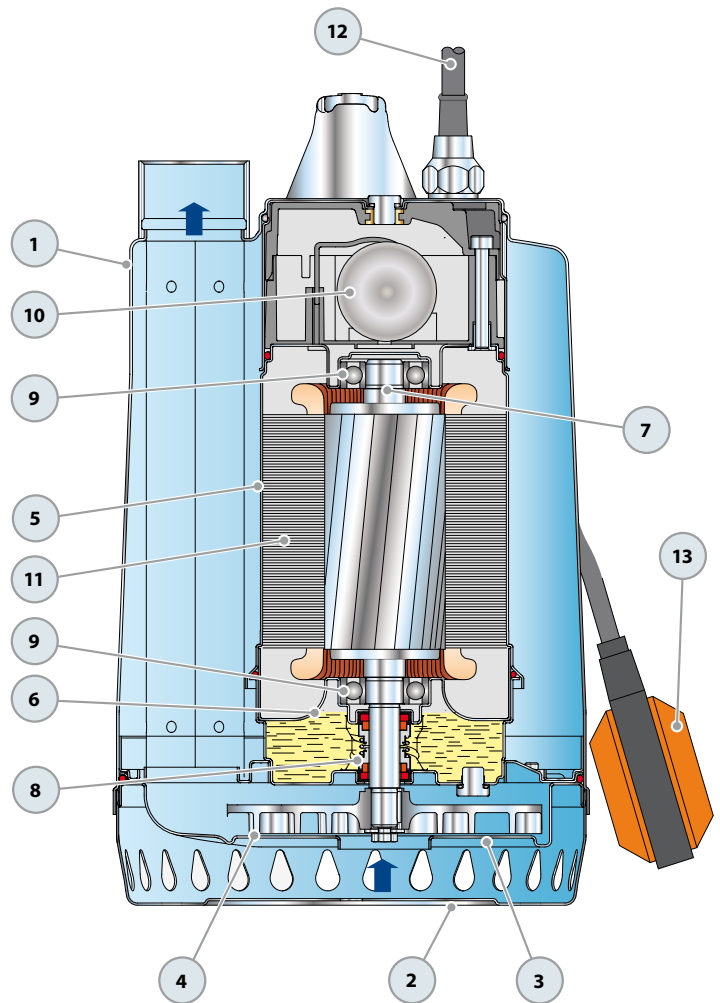

DIMENSIONS AND WEIGHT

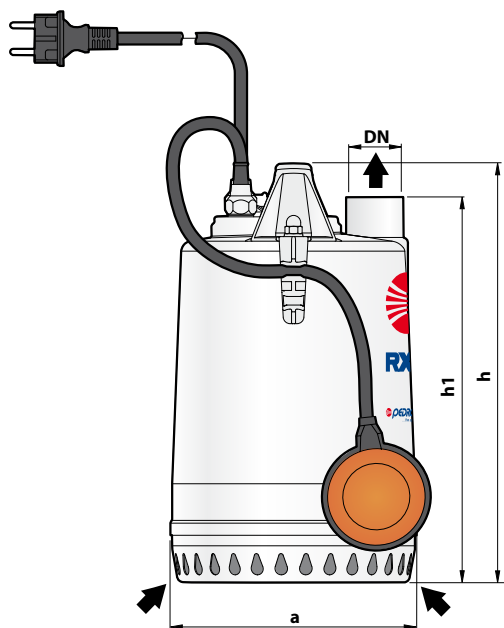

Typical installation

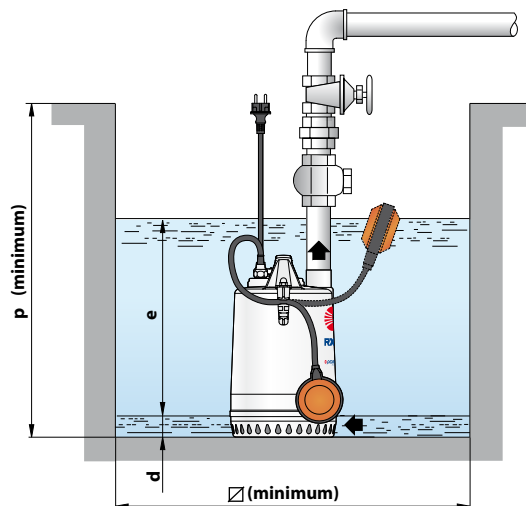

MODEL		PORT	DIMENSIONS mm							kg	
Single-phase	Three-phase	DN	a	h	h1	d	e	p	Ø	1~	3~
RXm 4	RX 4	1½"	220	367	336	25	variable	500	500	12.7	11.9
RXm 5	RX 5									13.7	12.7

ABSORPTION

MODEL	VOLTAGE (single-phase)		
	230 V	240 V	110 V
Single-phase	230 V	240 V	110 V
RXm 4	5.4 A	5.4 A	11.0 A
RXm 5	7.5 A	7.5 A	-

MODEL	VOLTAGE (three-phase)			
	230 V	400 V	240 V	415 V
Three-phase	230 V	400 V	240 V	415 V
RX 4	3.6 A	2.1 A	3.6 A	2.1 A
RX 5	6.0 A	3.5 A	6.0 A	3.5 A

PALLETIZATION

MODEL		GROUPAGE			CONTAINER				
Single-phase	Three-phase	n° pumps	H (mm)	kg		n° pumps	H (mm)	kg	
				1~	3~			1~	3~
RXm 4	RX 4	45	1388	589	553	60	1804	779	731
RXm 5	RX 5	45	1388	634	589	60	1804	839	779

