

50 Hz



e-MP Series

MPA, MPR, MPD, MPV

HIGH PRESSURE
MULTISTAGE PUMPS ACCORDING TO ISO 5199

Cod. 191002221 Rev. B Ed.05/2017

 **LOWARA**
a xylem brand

Xylect™

Xylect™ is pump solution software with an extensive online database of product information across the entire range of pumps and related products, with multiple search options and helpful project management facilities. The system holds up-to-date product information on thousands of products and accessories.

Xylect™ can be available:

On the website – www.xylect.com



On Mobile Apps



For more information, please, see page 115-116.

CONTENTS

General introduction	5
Design version	6
General characteristics	7
Identification code	9
Identification code and design overview	10
Rating plate	11
Pump cross-section and main components	12
Table of materials	16
Mechanical seals	20
Pressure/temperature limit	22
Motors (ErP 2009/125/EC)	24
Pumps (ErP 2009/125/EC)	32
Hydraulic performance range at 50 Hz	33
Operating characteristics at 50 Hz, 2 poles	34
Operating characteristics at 50 Hz, 4 poles	54
Dimensions and weights	67
e-MP with HYDROVAR	95
Accessories	101
Report and declarations	105
Technical appendix	107

e-MP SERIES

HYDRAULIC PERFORMANCE RANGE AT 50 Hz, 2 POLES

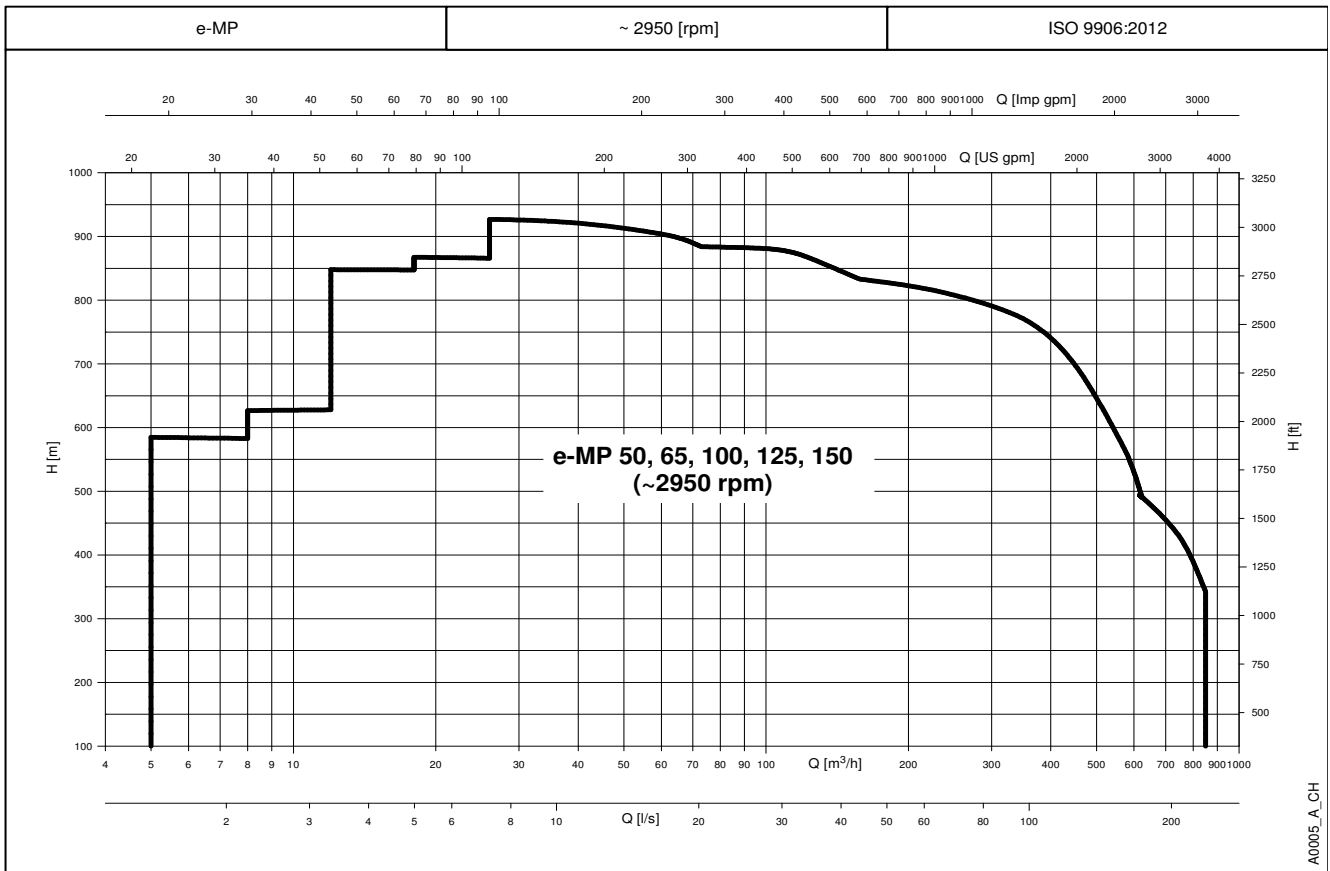

HYDRAULIC PERFORMANCE RANGE AT 50 Hz, 4 POLES

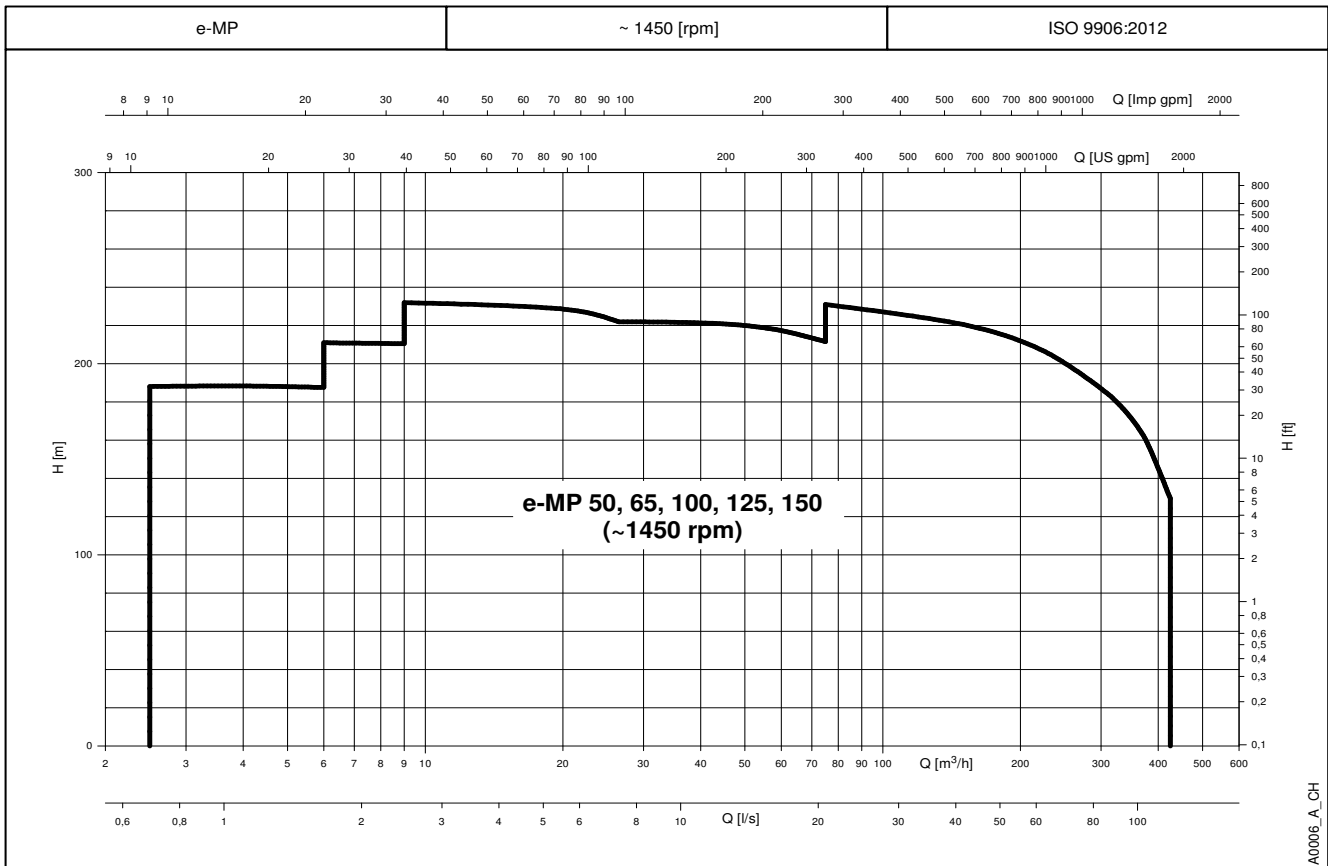

e-MP SERIES

HIGH PRESSURE MULTISTAGE RING SECTION PUMPS

Markets and applications:

➤ **General industry**

All productive industries, i.e. steel, sugar, timber, tire and rubber, pulp and paper, car, food and beverage.

Applications: Cooling and heating circuits for industrial processes, sprinkler systems, washing/cleaning systems, firefighting systems, filter systems, water transport, booster systems, water treatment systems.

➤ **Oil and gas**

on-shore platform, off-shore platforms, refineries, fracking.

Applications: Transport of crude oil, sea water/water injection, firefighting systems, water transport, water treatment.

➤ **Power plants**

Renewable energy, hydropower, biomass, geothermal, fossil power.

Applications: Boiler feed, condensate pumping, deaerator, water injection, water transport, auxiliary systems, firefighting systems, cooling and heating circuits, district cooling and heating system.

➤ **Mining**

Applications: Dewatering (filtered water), water transport, firefighting systems.

➤ **Agriculture**

Applications: water transport, irrigation.

➤ **Leisure industry**

i.e. skiing resorts, leisure parks, spas.

Applications: snow making (feeding the snow canons), water transport, water boosting.

➤ **Public utilities**

i.e. water works, desalination plants, drainage and flood protection, tunnels.

Applications: District cooling and heating systems, water transport, water treatment systems, desalination, reverse osmosis, nanofiltration, firefighting systems, booster systems.

➤ **Commercial building service**

Applications: Water transport, booster systems, firefighting systems, HVAC systems.

➤ **Others**

i.e. Auxiliary applications in chemical industry, all water boosting applications.

Applications: Boiler feed, condensate pumping, deaerator, water injection, water transport, auxiliary systems, firefighting systems, cooling and heating circuits, district cooling and heating system.

Pumpable fluids:

- | | |
|----------------------------|-------------------------|
| ➤ Water | ➤ Hot water |
| ➤ Grey/used water | ➤ Condensate |
| ➤ Ground water | ➤ Cooling/heating water |
| ➤ Potable water | ➤ Solvents |
| ➤ Thermal water | ➤ Lubricants |
| ➤ Sea water in all regions | ➤ Crude oil |
| ➤ Brackish water | ➤ Oil emulsions |
| ➤ Feed water | ➤ Fuels |

Pumpable fluids:

The **e-MP** series is a highly efficient and flexible multistage ring section pump. 4 mechanical models build the basic platform for various horizontal and vertical configurations to meet requirements for the defined markets, applications and liquids.

**e-MP SERIES
DESIGN VERSIONS**

CONFIGURATION	DESCRIPTION
<p>Model MPA</p> 	<p>Closed radial Impeller and U-turn diffuser design</p> <ul style="list-style-type: none"> • Horizontal shaft design • Axial suction nozzle • Radial discharge nozzle (left, top, right) • Drive on discharge side • Radial/Axial roller bearing on drive side • Plain bearing on suction side • Axial thrust balancing by drum design • Shaft sealing on discharge side only • Bare shaft or pump unit • Driver: electric motor - IEC or NEMA standard • IC-engine, turbine • Temperature range: (-25°C) -10°C to 140°C (180°C) • Inlet pressure: up to 10 bar
<p>Model MPR</p> 	<p>Closed radial Impeller and U-turn diffuser design</p> <ul style="list-style-type: none"> • Horizontal shaft design • Axial suction nozzle • Radial suction nozzle (left, top, right) • Radial discharge nozzle (left, top, right) • Drive on discharge side • Radial/Axial roller bearing on drive side • Plain bearing on suction side • Axial thrust balancing by drum design • Shaft sealing on discharge side only • Bare shaft or pump unit • Driver: electric motor - IEC or NEMA standard • IC-engine, turbine • Temperature range: (-25°C) -10°C to 140°C (180°C) • Inlet pressure: up to 10 bar
<p>Model MPD</p> 	<p>Closed radial Impeller and U-turn diffuser design</p> <ul style="list-style-type: none"> • Horizontal shaft design • Axial suction nozzle • Radial suction nozzle (left, top, right) • Radial discharge nozzle (left, top, right) • Drive on discharge side (optional suction side) • Radial/Axial roller bearing on drive side • Radial roller bearing on suction side • Axial thrust balancing by drum design • Shaft sealing on suction and discharge side • Bare shaft or pump unit • Driver: electric motor - IEC or NEMA standard • IC-engine, turbine • Temperature range: (-25°C) -10°C to 140°C (180°C) • Inlet pressure: up to 40 bar
<p>Model MPV</p> 	<p>Closed radial Impeller and U-turn diffuser design</p> <ul style="list-style-type: none"> • Vertical shaft design • Radial suction nozzle (0°, 90°, 180°, 270°) • Radial discharge nozzle (0°, 90°, 180°, 270°) • Drive on discharge side • Radial/Axial roller bearing on drive side • Plain bearing on suction side • Axial thrust balancing by drum design • Shaft sealing on discharge side only • Bare shaft or pump unit • Driver: electric motor - IEC or NEMA standard up to 355kW (400kW) • Temperature range: (-25°C) -10°C to 120°C • Inlet pressure: up to 10 bar

e-MP SERIES GENERAL CHARACTERISTICS

STAGE NUMBERS & POWER LIMITS AT 50Hz										
		DESIGN	MPA		MPR		MPD		MPV	
		SPEED [rpm]	2950	1475	2950	1475	2950	1475	2950	1475
SIZE	HYDRAULIC									
50	A	Max. Stages	15	18	15	18	15	18	15	18
		Max. Power [kW]	75	11	75	11	75	11	75	11
	B	Max. Stages	15	18	15	18	15	18	14	18
		Max. Power [kW]	110	15	110	15	110	15	90	15
65	A	Max. Stages	11	15	11	15	11	15	8	15
		Max. Power [kW]	132	22	132	22	132	22	90	22
	B	Max. Stages	10	15	10	15	10	15	6	15
		Max. Power [kW]	160	30	160	30	160	30	90	30
100	A	Max. Stages	7	11	7	11	7	11	7	11
		Max. Power [kW]	250	55	250	45	250	45	250	45
	B	Max. Stages	7	11	7	11	7	11	6	11
		Max. Power [kW]	355	75	355	75	355	75	250	75
125	A	Max. Stages	5	8	5	8	5	8	5	8
		Max. Power [kW]	450	110	450	110	450	110	450	110
	B	Max. Stages	5	7	5	7	5	7	3	7
		Max. Power [kW]	630	110	630	110	630	110	450	110
150	A	Max. Stages	5	6	5	6	5	6	2	6
		Max. Power [kW]	900	160	900	160	900	160	450	160
	B	Max. Stages	4	6	4	6	4	6	2	6
		Max. Power [kW]	1250	250	1250	250	1250	250	450	250

MP_models-50-en_b_sc

OPERATING DATA

DATA	VALUE
Mechanical sizes	DN50 to DN150
Power	2-pole operation: 5,5 kW to 1.250 kW (2-pole) / 7,5 hp to 1.700 hp 4-pole operation: 2,2 kW to 250 kW (4-pole) / 3 hp to 335 hp
Heads	up to 950 m / 3.100 ft
Flows	up to 850 m ³ /h / 3.740 USg.p.m
Temperature	-25°C to + 140°C, optional 180°C / -13°F to +284°F, optional 356°F
Operating pressures	up to 100 bar / 1.450 psi

En-Rev_B

e-MP SERIES
GENERAL CHARACTERISTICS

Operating range by size and design

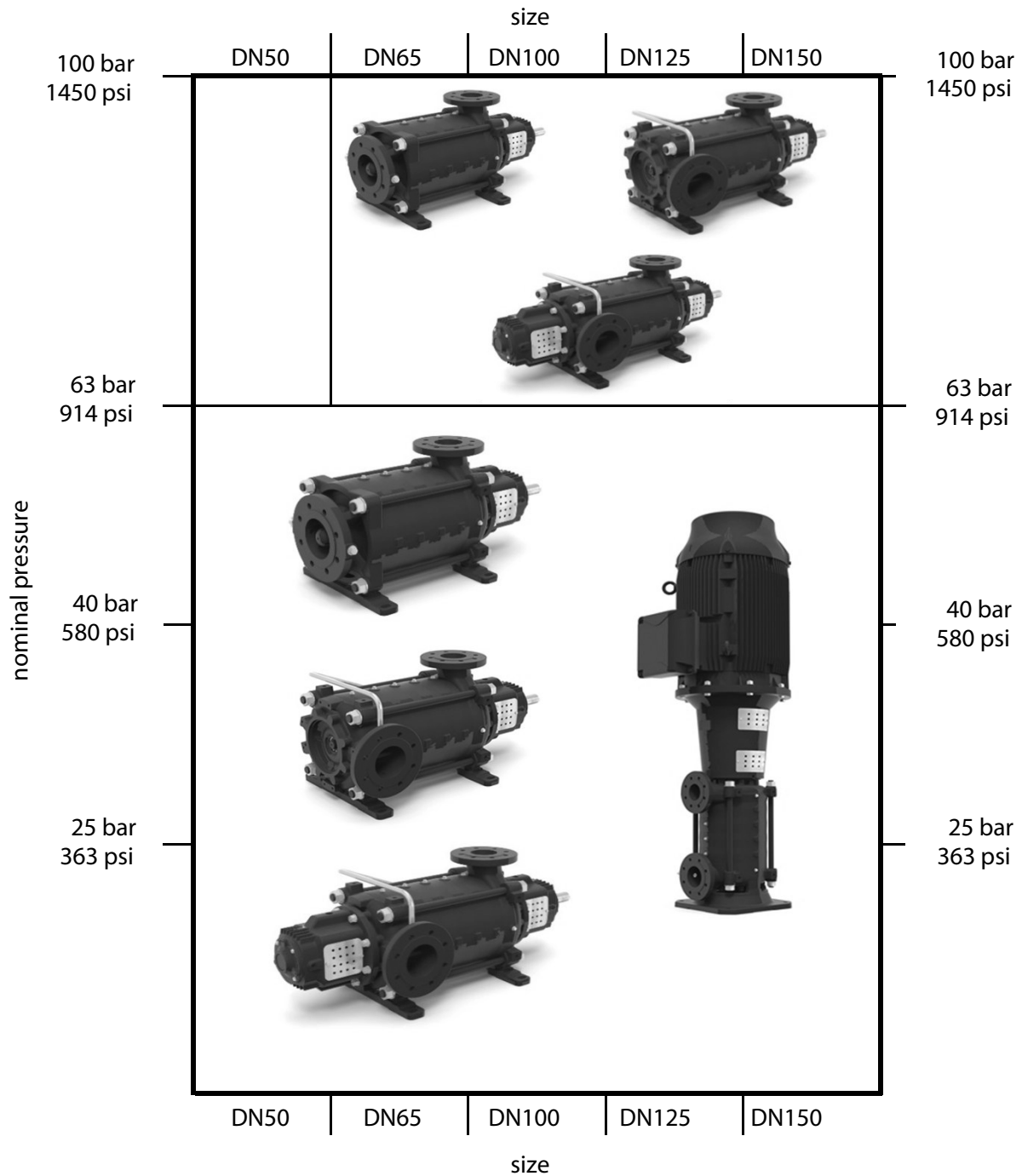

e-MP SERIES IDENTIFICATION CODE

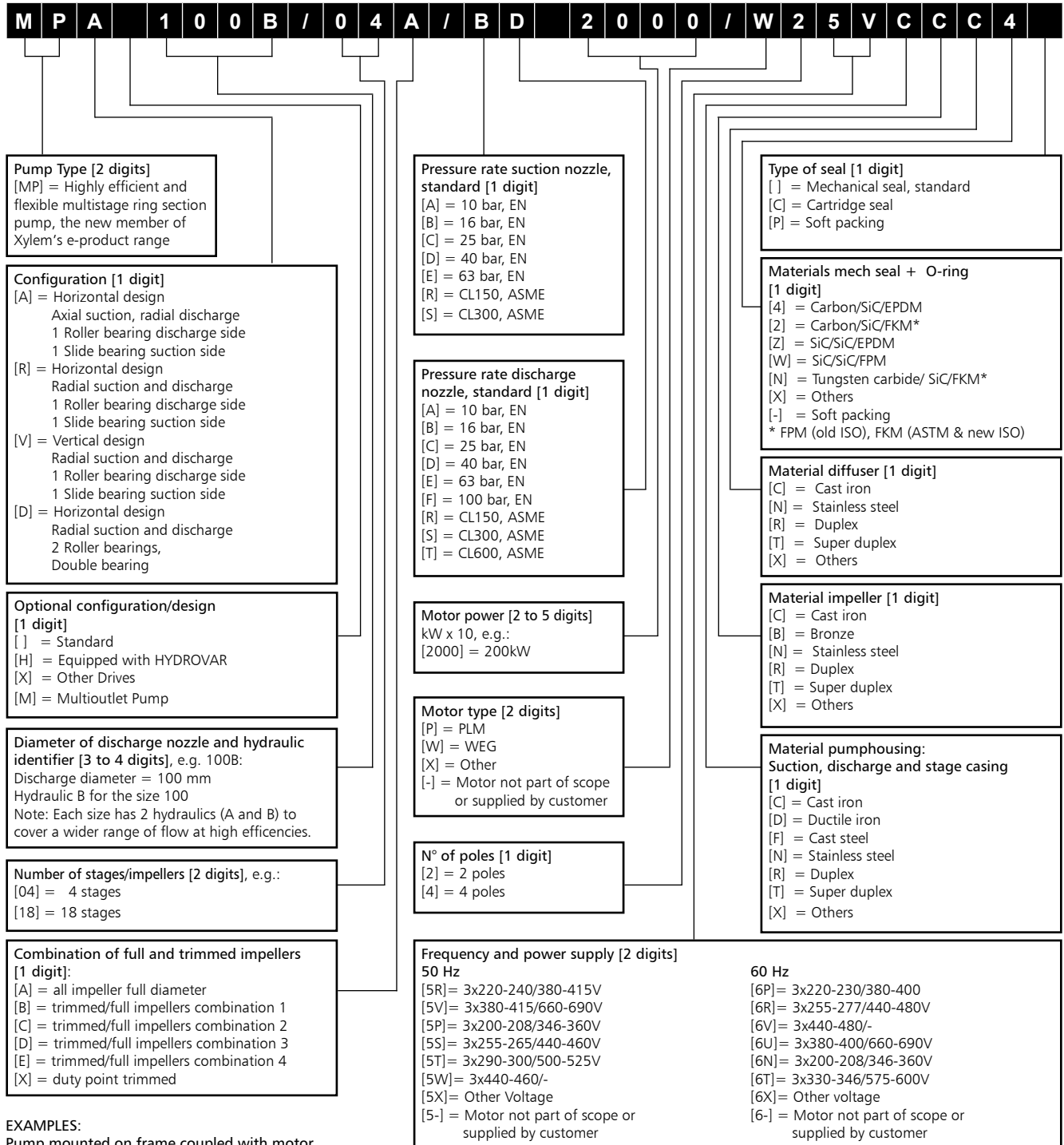

EXAMPLES:

Pump mounted on frame coupled with motor
MPA100B/04A/BD2000/W25VCC4

Series e-MP, horizontal configuration, axial suction inlet, radial discharge nozzle, size DN100, hydraulic B, 4 stages/impellers, all impellers with full diameter, 16 bar suction nozzle, 40 bar discharge nozzle, coupled with a 200kW motor from WEG with 2 poles for 50Hz 3x380-415/660-690V supply, frame mounted, suction and discharge casing material made of cast iron, impellers and diffusers made of cast iron, mechanical seal Carbon/SiC, o-rings made of EPDM, mechanical seal.

Pump mounted on frame, with coupling, motor not part of scope or supplied by customer
MPA100B/04A/BD2000/-25-CCC4

Series e-MP, horizontal configuration, axial suction inlet, radial discharge nozzle, size DN100, hydraulic B, 4 stages/impellers, all impellers with full diameter, 16 bar suction nozzle, 40 bar discharge nozzle, frame mounted, coupling and coupling guard included, prepared to assemble a 200kW, 2 pole motor, 50Hz, suction and discharge casing material made of cast iron, impellers and diffusers made of cast iron, mechanical seal Carbon/SiC, o-rings made of EPDM, mechanical seal.

Bareshaft pump
MPA100B/04A/BD/-25-CCC4

Series e-MP, horizontal configuration, axial suction inlet, radial discharge nozzle, size DN100, hydraulic B, 4 stages/impellers, all impellers with full diameter, 16 bar suction nozzle, 40 bar discharge nozzle, 2 pole motor, 50Hz, suction and discharge casing material made of cast iron, impellers and diffusers made of cast iron, mechanical seal Carbon/SiC, o-rings made of EPDM, mechanical seal.

e-MP SERIES IDENTIFICATION CODE AND DESIGN OVERVIEW

Example:

MPA100B/04A/BD2000/W25VCCC4

Digits	Description
MP	Highly efficient and flexible multistage ring section pump Various design features for optimized efficiency values over the complete performance range offering configuration flexibility for a wide range of applications in different markets.
A	Mechanical model Total 4 models to meeting different installation requirements 3 horizontal models: MPA, MPR, MPD 1 vertical model: MPV Pumphousing: Suction casings are available with radial and axial arranged nozzles Discharge casings are available with radial arranged nozzles Radial casing nozzles (suction and discharge) can be turned in 90°C steps Sealing: by O-rings Bearings: Depending on mechanical model: Drive end: Roller bearing (grease or oil lubricated) Non drive end: Roller bearing (grease or oil lubricated) or plain bearing (lubricated by pumped liquid) Coupling and Coupling Guard: Horizontal models: Flexible coupling with and without spacer Vertical model: Close coupled with flexible coupling.
100	Mechanical size (nominal discharge nozzle diameter in mm) Total 5 mechanical sizes: DN50, DN65, DN100, DN125, DN150 to cover best efficiencies points (BEP) over the flow performance range.
B	Hydraulic identifier Total 10 hydraulics: 2 hydraulics (A,B) by mechanical size to increase the coverage of best efficiency points (BEP) over the flow performance range.
04A	Number of stages and impeller trimming identification Up to 18 stages (mechanical size 50) 4 standard impeller trimmings and optional trim of impellers exactly to the required duty point for an optimized efficiency. Impeller design: closed radial with curved vanes.
BD	Nominal pressure identification for suction and discharge pumphousing Housing for nominal pressures, flanges are available for EN and ASME standard: EN: 10, 16, 25, 40, 63, 100bar ASME: CL150, CL300, CL600.
2000	Motor power kW x 10
W2	Motor type and number of poles standard IEC and NEMA motors with 2 and 4poles engineered to order drive options: diesel engine, turbine.
5V	Frequency and power supply identification 50Hz and 60Hz 3 phase power supply for various voltages, up to high voltage.
CCC	Material identification for pumphousing (suction, discharge and stage casing), impeller and diffuser Pumphousing: cast iron, ductile iron, steel, stainless steel (AISI 316), duplex stainless steel, super duplex stainless steel Impeller: cast iron, bronze, stainless steel (AISI 316), duplex stainless steel, super duplex stainless steel diffusor: cast iron, stainless steel (AISI 316), duplex stainless steel, super duplex stainless steel.
4()	Material identification for mechanical seal and O-ring and type of seal Elastomers: EPM, FKM Shaft sealing: mechanical seal (EN 12756), cartridge seal (single, single quench, double) packing.

En-Rev_A

**e-MP SERIES
RATING PLATE**

ELECTRIC PUMP

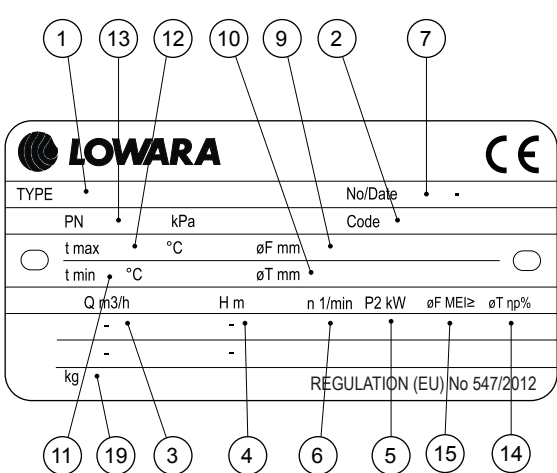

LOWARA		CE	
TYPE	No/Date		
PN	kPa	Code	
t max °C	°C	øF mm	
t min °C	°C	øT mm	
Q m ³ /h	H m	n 1/min	P ₂ kW
			øF MEI ≥
			øT ηp%
kg	REGULATION (EU) No 547/2012		

PUMP ONLY

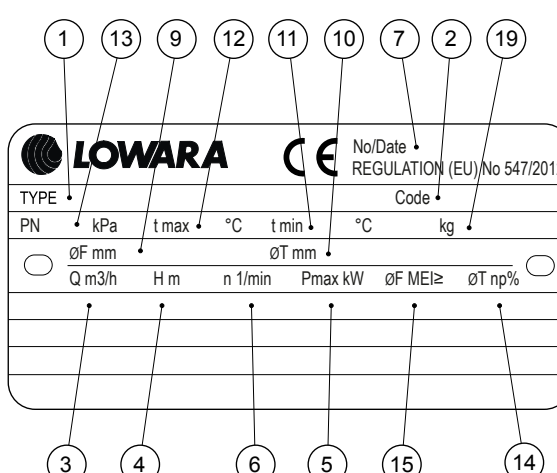

LOWARA		CE		No/Date	REGULATION (EU) No 547/2012	
TYPE	Code					
PN	kPa	t max °C	t min °C	kg		
øF mm	øT mm					
Q m ³ /h	H m	n 1/min	P _{max} kW	øF MEI ≥	øT ηp%	

LEGEND

- 1 - Electric pump unit type
- 2 - Electric pump unit code
- 3 - Flow range
- 4 - Head range
- 5 - Nominal or maximum pump power
- 6 - Speed
- 7 - Serial number, or order number + order position number
- 9 - Full impeller diameter (only filled in for trimmed impellers)
- 10 - Trimmed impeller diameter (only filled in for trimmed impellers)
- 11 - Minimum operating liquid temperature
- 12 - Maximum operating liquid temperature
- 13 - Maximum operating pressure
- 14 - Hydraulic efficiency in best efficiency point (50 Hz)
- 15 - Minimum efficiency index MEI, as per Regulation (EU) No 547/2012 (50 Hz)
- 19 - Weight

LEGEND

- 1 - Pump type
- 2 - Pump code
- 3 - Flow range
- 4 - Head range
- 5 - Maximum absorbed pump power
- 6 - Speed
- 7 - Serial number, or order number + order position number
- 9 - Full impeller diameter (only filled in for trimmed impellers)
- 10 - Trimmed impeller diameter (only filled in for trimmed impellers)
- 11 - Minimum operating liquid temperature
- 12 - Maximum operating liquid temperature
- 13 - Maximum operating pressure
- 14 - Hydraulic efficiency in best efficiency point (50 Hz)
- 15 - Minimum efficiency index MEI, as per Regulation (EU) No 547/2012 (50 Hz)
- 19 - Weight

Note for electric pump unit: refer to motor data plate for electrical data.

**MPA SERIES
ELECTRIC PUMP CROSS-SECTION AND MAIN COMPONENTS**

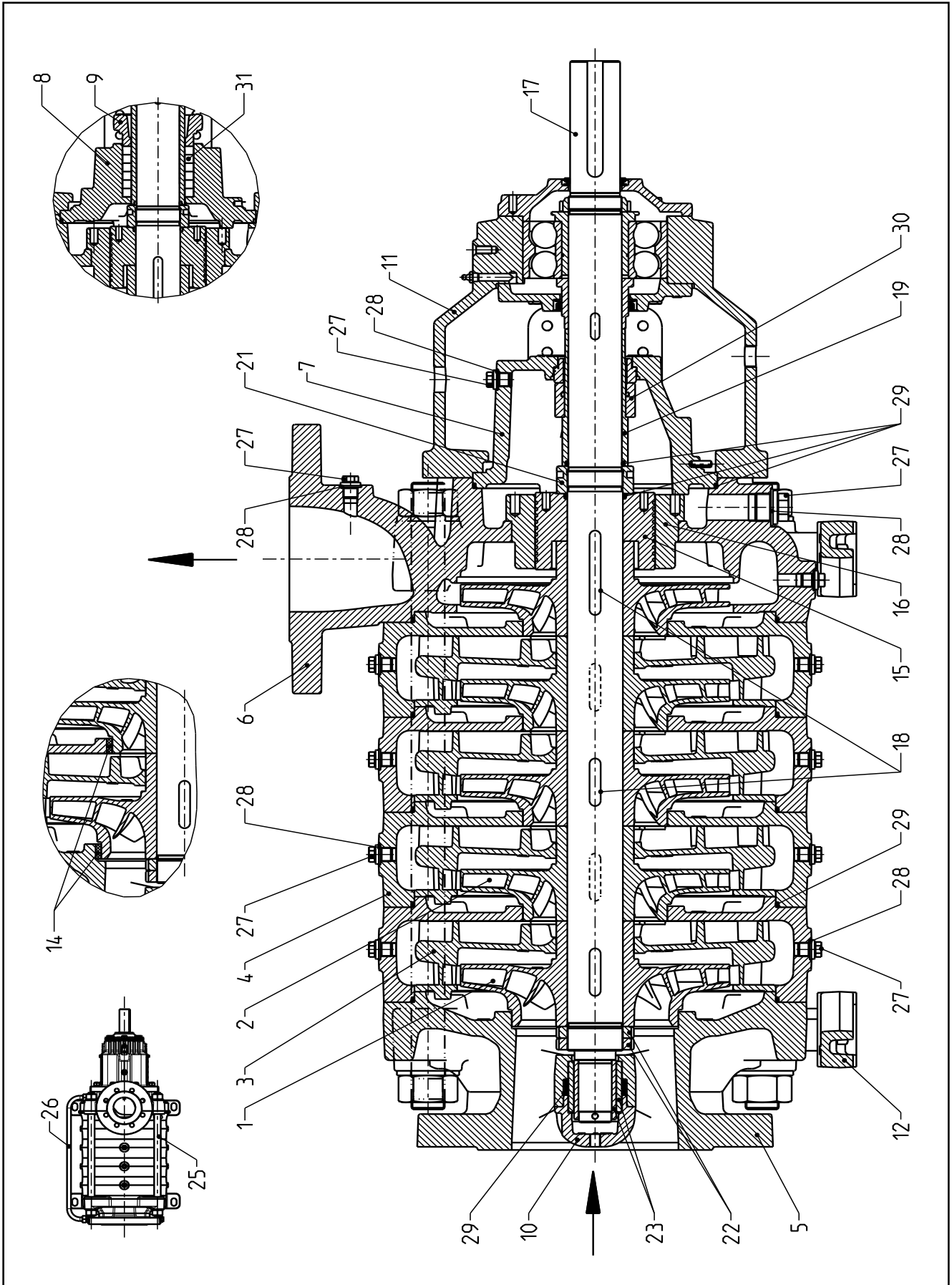

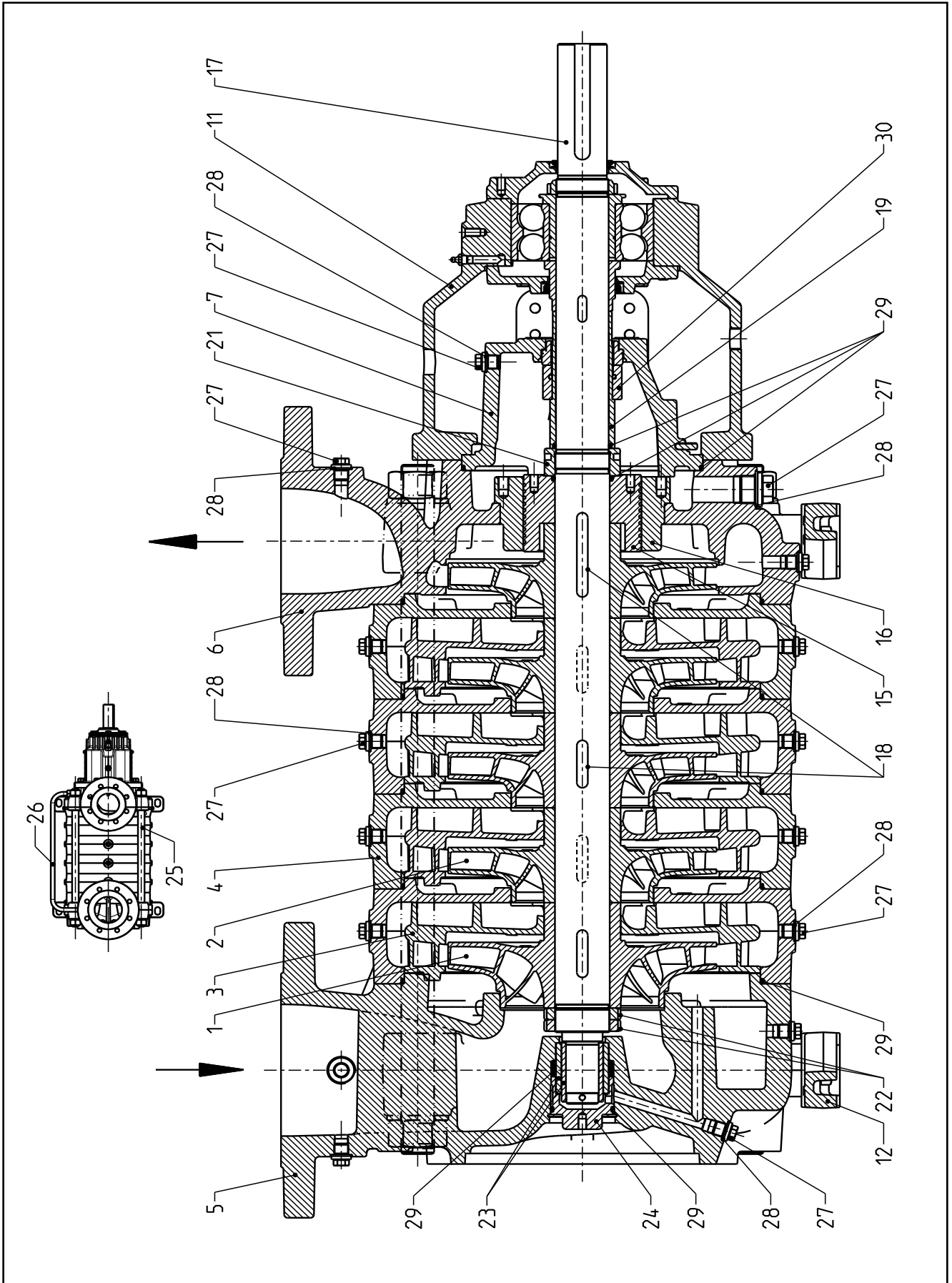
MPR SERIES**ELECTRIC PUMP CROSS-SECTION AND MAIN COMPONENTS**

**MPD SERIES
ELECTRIC PUMP CROSS-SECTION AND MAIN COMPONENTS**

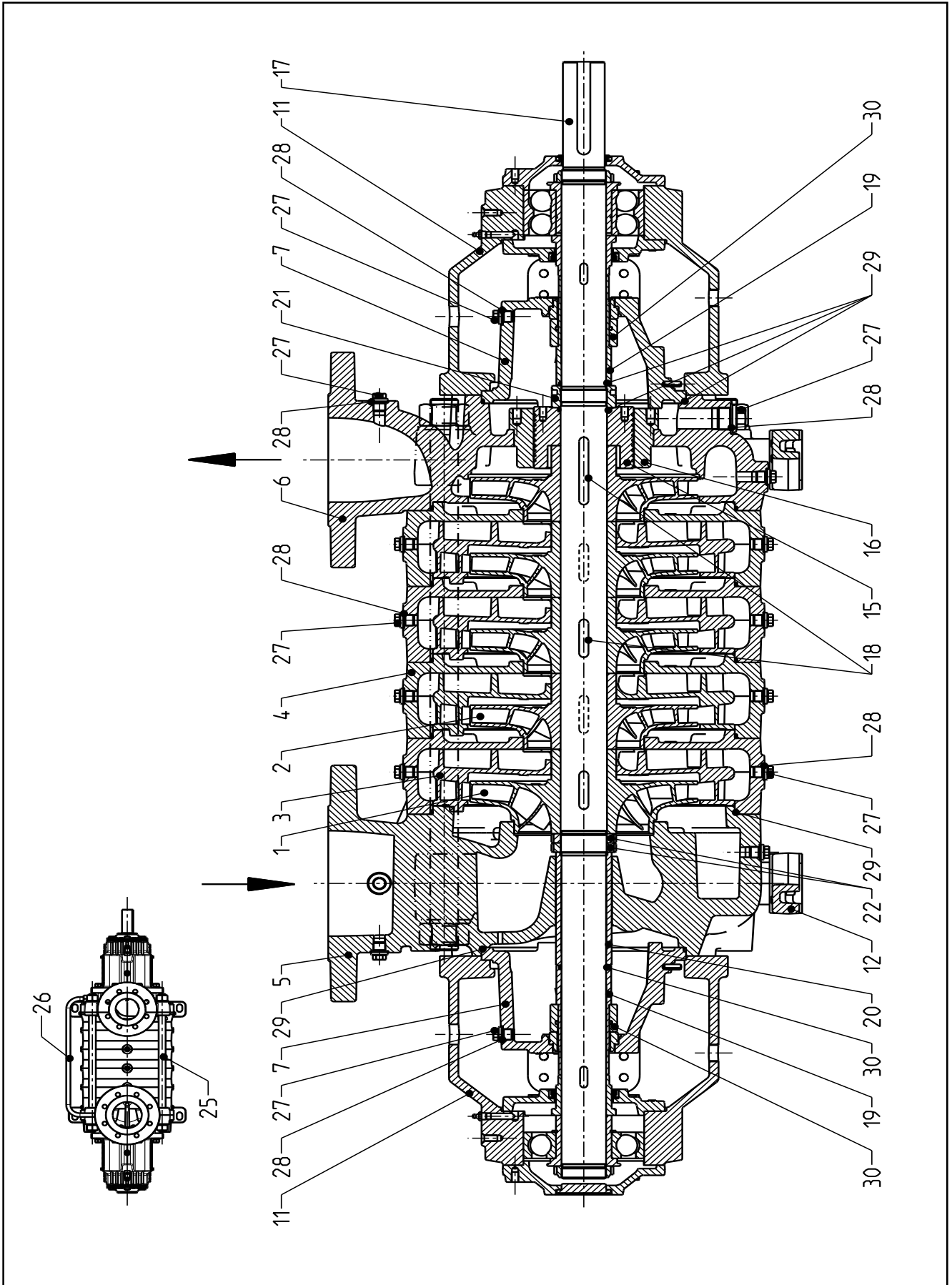

MPV SERIES

ELECTRIC PUMP CROSS-SECTION AND MAIN COMPONENTS

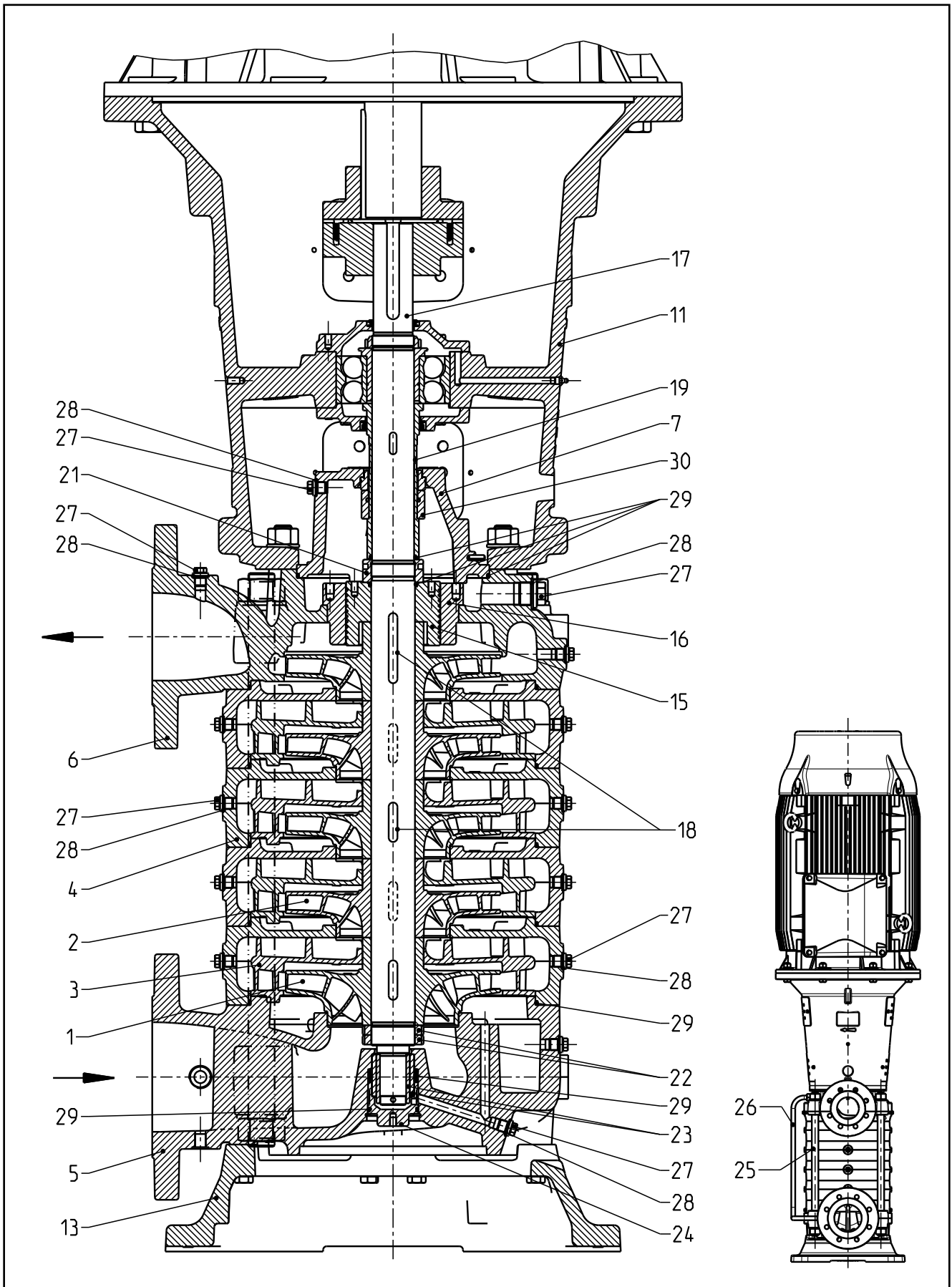

e-MP SERIES TABLE OF MATERIAL REFERENCE STANDARDS

COMPONENTS	MATERIALS	REFERENCE STANDARDS	
		EUROPE	USA ^{*)}
JL1020	Cast Iron	EN 1561 - GJL-150	ASTM Class 25
JL1030	Cast Iron	EN 1561 - GJL-200	ASTM Class 30
JL1040	Cast Iron	EN 1561 - GJL-250	ASTM Class 35
JS1030	Ductile Iron	EN 1563 - GJS-400-15	ASTM 65-45-12
CC480K	Bronze	EN 1982 - CuSn10-C	ASTM C90700
1.4408	Austenitic Stainless Steel	EN 10213-4 - GX5CrNiMo19-11-2	ASTM CF8M
1.4517	Duplex Stainless Steel	EN 10213-4 - GX2CrNiMoCuN25-6-3-3	ASTM CD4MCuN
1.4469	Super Duplex Stainless Steel	EN 10213-4 - GX2CrNiMoCuN26-7-4	ASTM CE3MN
1.0038	Carbon Steel	EN 10025 - S235JR	ASTM Grade C, D
1.4057	Stainless Steel	EN 10088-1 - X17CrNiMo16-2	ASTM 431
1.4571	Stainless Steel	EN 10088-1 - X6CrNiMo17-12-2	ASTM 316Ti
1.4539	Austenitic Stainless Steel	EN 10088-1 - X1CrNiMo25-20-5	ASTM 904L
1.4462	Duplex Stainless Steel	EN 10088-1 - X2CrNiMo22-5-3	ASTM F51
1.4410	Super Duplex Stainless Steel	EN 10088-1 - X2CrNiMo25-7-4	ASTM F53
EPDM	Ethylen-Propylen-Dien-Elastomer	-	-
FKM/FPM	Fluoro-Elastomer	-	-
AFM34	Asbestos free synthetic fiber	-	-

*) ... Similar Grade

MP_materials-50-en_b_tc

e-MP SERIES TABLE OF MATERIAL CODE

COMPONENTS	Material Code									
	CCC	CBC	CNC	DCC	DBC	DNC	NNN	R N N	R R R	TTT
Impeller	Cast Iron	Bronze	Stainless Steel	Cast Iron	Bronze	Stainless Steel	Stainless Steel	Stainless Steel	Duplex	Super Duplex
Diffuser	Cast Iron	Cast Iron	Cast Iron	Cast Iron	Cast Iron	Cast Iron	Stainless Steel	Stainless Steel	Duplex	Super Duplex
Casing	Cast Iron	Cast Iron	Cast Iron	Ductile Iron	Ductile Iron	Ductile Iron	Stainless Steel	Duplex	Duplex	Super Duplex
Shaft	Stainless Steel	Stainless Steel	Stainless Steel	Stainless Steel	Stainless Steel	Stainless Steel	Stainless Steel	Stainless Steel	Duplex	Super Duplex
Shaft Sleeve	Stainless Steel	Stainless Steel	Stainless Steel	Stainless Steel	Stainless Steel	Stainless Steel	Stainless Steel	Stainless Steel	Duplex	Super Duplex
Relief Pipe	Stainless Steel	Stainless Steel	Stainless Steel	Stainless Steel	Stainless Steel	Stainless Steel	Stainless Steel	Stainless Steel	Austenitic Steel	Austenitic Steel
Plain Bearing	Tungsten Carbide									

MP_material-en_a_tc

e-MP SERIES

TABLE OF MATERIALS CAST IRON VERSION

REF. N.	PART	PUMP MATERIAL CODE (STANDARD)		
		CCC	CBC	CNC
	MAXIMAL WORKING PRESSURE [bar]	40	40	40
1	SUCTION IMPELLER	JL1030	CC480K	1.4408
2	IMPELLER	JL1030	CC480K	1.4408
3	DIFFUSER		JL1020	
4	STAGE CASING		JL1040	
5	SUCTION CASING		JL1040	
6	DISCHARGE CASING		JL1040	
7	SEAL COVER		JL1040	
8	STUFFING BOX COVER		JL1040	
9	STUFFING BOX GLAND		JL1040	
10	SLIDE BEARING CAP		JL1040	
11	BEARING BRACKET / MOTOR ADAPTER		JL1040	
12	PUMP FOOT HORIZONTAL		JL1040 ¹⁾	
13	PUMP FOOT VERTICAL		JL1040	
14	WEAR RING (optional)		optional (1.4462)	
15	DRUM		1.4057	
16	DRUM BUSH		JL1040	
17	SHAFT		1.4057	
18	KEY		1.4571	
19	SHAFT SLEEVE		1.4057	
20	SPACER SLEEVE		1.4057	
21	SHAFT NUT		1.4057	
22	IMPELLER NUT		A4 ²⁾	
23	PLAIN BEARING (SLEEVE & BUSH)		Tungsten Carbide (9% Ni-Binder)	
24	PLAIN BEARING COVER		1.4057	
25	TIE ROD		ETG100	
26	CIRCULATION PIPE		1.4571	
27	PLUG		Galvanized Steel	
28	GASKET		AFM34 ³⁾	
29	O-RING		EPDM (FPM/FKM)	
30	MECHANICAL SEAL		CARBON/SIC/EP	
31	SOFT PACKING		ramie fibre packing with special PTFE-impregnation	
	NUT, WASHER & SCREW		Galvanized Steel	

1) ... 1.0038 for Size 125 and 150

2) ... 1.4401 / 1.4404 / 1.4571

3) ... Asbestos free synthetic fiber AFM34

e-MP SERIES
TABLE OF MATERIALS DUCTILE IRON VERSION

REF. N.	PART	PUMP MATERIAL CODE (STANDARD)		
		D C C	D B C	D N C
	MAXIMAL WORKING PRESSURE [bar]	63	63	63
1	SUCTION IMPELLER	JL1030	CC480K	1.4408
2	IMPELLER	JL1030	CC480K	1.4408
3	DIFFUSER		JL1020	
4	STAGE CASING		JS1030	
5	SUCTION CASING		JS1030	
6	DISCHARGE CASING		JS1030	
7	SEAL COVER		JS1030	
8	STUFFING BOX COVER		JS1030	
9	STUFFING BOX GLAND		JL1040	
10	SLIDE BEARING CAP		JL1040	
11	BEARING BRACKET / MOTOR ADAPTER		JL1040	
12	PUMP FOOT HORIZONTAL		JL1040 ¹⁾	
13	PUMP FOOT VERTICAL		JL1040	
14	WEAR RING (optional)		optional (1.4462)	
15	DRUM		1.4057	
16	DRUM BUSH		JL1040	
17	SHAFT		1.4057	
18	KEY		1.4571	
19	SHAFT SLEEVE		1.4057	
20	SPACER SLEEVE		1.4057	
21	SHAFT NUT		1.4057	
22	IMPELLER NUT		A4 ²⁾	
23	PLAIN BEARING (SLEEVE & BUSH)		Tungsten Carbide (9% Ni-Binder)	
24	PLAIN BEARING COVER		1.4057	
25	TIE ROD		ETG100	
26	CIRCULATION PIPE		1.4571	
27	PLUG		Galvanized Steel	
28	GASKET		AFM34 ³⁾	
29	O-RING		EPDM (FPM/FKM)	
30	MECHANICAL SEAL		CARBON/SIC/EP	
31	SOFT PACKING		ramie fibre packing with special PTFE-impregnation	
	NUT, WASHER & SCREW		Galvanized Steel	

1) ... 1.0038 for Size 125 and 150

2) ... 1.4401 / 1.4404 / 1.4571

3) ... Asbestos free synthetic fiber AFM34

e-MP SERIES

TABLE OF MATERIALS STAINLESS STEEL VERSION

REF. N.	PART	PUMP MATERIAL CODE (STANDARD)			OPTIONAL
		N N N	R N N	R R R	TTT
	MAXIMAL WORKING PRESSURE [bar]	40	63	63	63
1	SUCTION IMPELLER	1.4408	1.4408	1.4517	1.4469
2	IMPELLER	1.4408	1.4408	1.4517	1.4469
3	DIFFUSER	1.4408	1.4408	1.4517	1.4469
4	STAGE CASING	1.4408	1.4408	1.4517	1.4469
5	SUCTION CASING	1.4408	1.4517	1.4517	1.4469
6	DISCHARGE CASING	1.4408	1.4517	1.4517	1.4469
7	SEAL COVER	1.4408	1.4408	1.4517	1.4469
8	STUFFING BOX COVER	1.4408	1.4408	n/a	n/a
9	STUFFING BOX GLAND	1.4408 ¹⁾	1.4408 ¹⁾	n/a	n/a
10	SLIDE BEARING CAP	1.4462	1.4462	1.4462	1.4410
11	BEARING BRACKET / MOTOR ADAPTER	JL1040			
12	PUMP FOOT HORIZONTAL	JL1040 ²⁾			
13	PUMP FOOT VERTICAL	JL1040			
14	WEAR RING (optional)	1.4462	1.4462	1.4462	1.4410
15	DRUM	1.4057	1.4057	1.4462	1.4410
16	DRUM BUSH	1.4462	1.4462	1.4462	1.4410
17	SHAFT	1.4462	1.4462	1.4462	1.4410
18	KEY	1.4571	1.4571	1.4462	1.4410
19	SHAFT SLEEVE	1.4462	1.4462	1.4462	1.4410
20	SPACER SLEEVE	1.4462	1.4462	1.4462	1.4410
21	SHAFT NUT	1.4410	1.4410	1.4410	1.4410
22	IMPELLER NUT	A4 ³⁾	A4 ³⁾	1.4410	1.4410
23	PLAIN BEARING (SLEEVE & BUSH)	Tungsten Carbide (9% Ni-Binder)			
24	PLAIN BEARING COVER	1.4462	1.4462	1.4462	1.4410
25	TIE ROD	ETG100			
26	CIRCULATION PIPE	1.4571	1.4571	1.4539	
27	PLUG	1.4571	1.4571	1.4462	1.4410
28	GASKET	AFM34 ⁴⁾			
29	O-RING	EPDM (FPM/FKM)			
30	MECHANICAL SEAL	CARBON/SIC/EP		CARBON/SIC/EP ⁵⁾	CARBON/SIC/EP ⁶⁾
31	SOFT PACKING	ramie fibre / PTFE-impregnation		n/a	n/a
	NUT, WASHER & SCREW	Galvanized Steel			

1) ... 1.4571 for Size 100, 125 and 150

2) ... 1.0038 for Size 125 and 150

3) ... 1.4401 / 1.4404 / 1.4571

4) ... Asbestos free synthetic fiber AFM34

5) ... Metal parts Duplex Steel

6) ... Metal parts Hastelloy C4

e-MP SERIES MECHANICAL SEALS

(Mechanical seal with mounting dimensions according to EN 12756 and ISO 3069 WITH L_{1k})

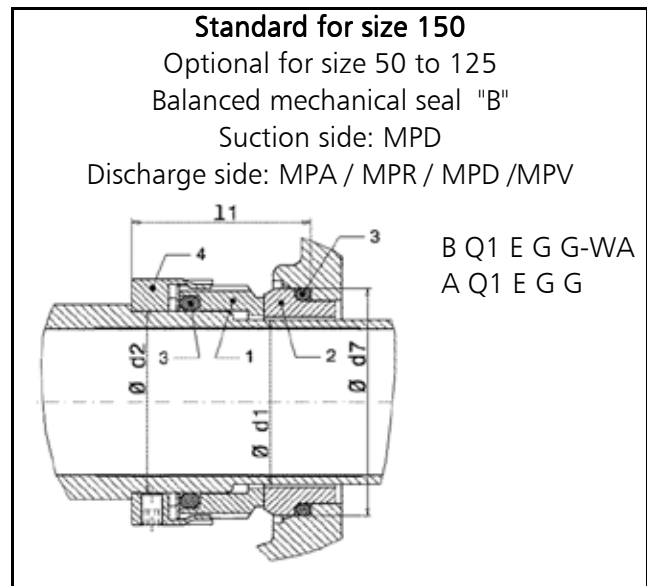
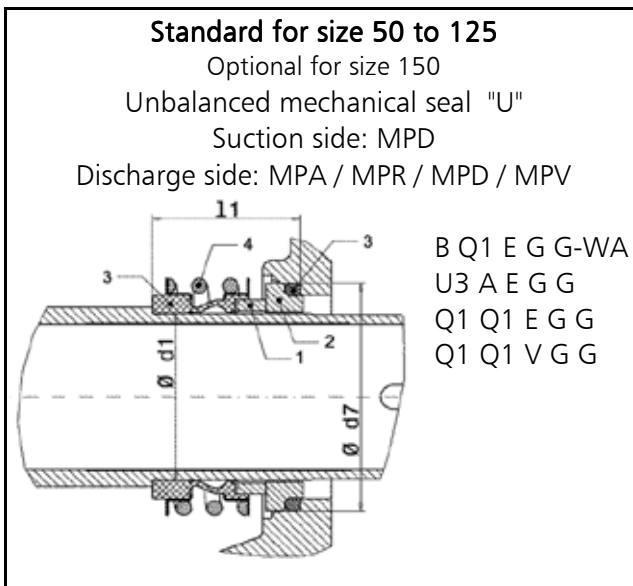

A0036_A_SC

LIST OF MATERIALS

POSITION 1 - 2	POSITION 3	POSITION 4
B : Resin impregnated carbon	E : EPDM	G : AISI 316
A : Antimony impregnated carbon	V : FKM (FPM)	
Q₁ : Silicon carbide		
U₃ : Tungsten carbide		

MP_Mech_Seal-en_a_tm

TYPE OF SEAL

TYPE	POSITION			
	1 ROTATING ASSEMBLY	2 FIXED ASSEMBLY	3 ELASTOMERS	4 SPRINGS
B Q1 E G G - WA	B	Q1	E	G
U3 A E G G	U3	A	E	G
Q1 Q1 E G G	Q1	Q1	E	G
Q1 Q1 V G G	Q1	Q1	V	G
A Q1 E G G	A	Q1	E	G

MP_Mech_Seal-en_a_tc

TABLE OF DIMENSIONS

PUMP SIZE	DIMENSIONS [mm]			
	Ø d1	Ø d2	Ø d7	l1 (=l _{1k})
50	38	43	56	45
65	43	48	61	45
100	55	60	75	47,5
125	65	70	85	52,5
150	75	80	97	60

MP_MS_dim-en_a_td

e-MP SERIES MECHANICAL SEAL SELECTION DIAGRAM

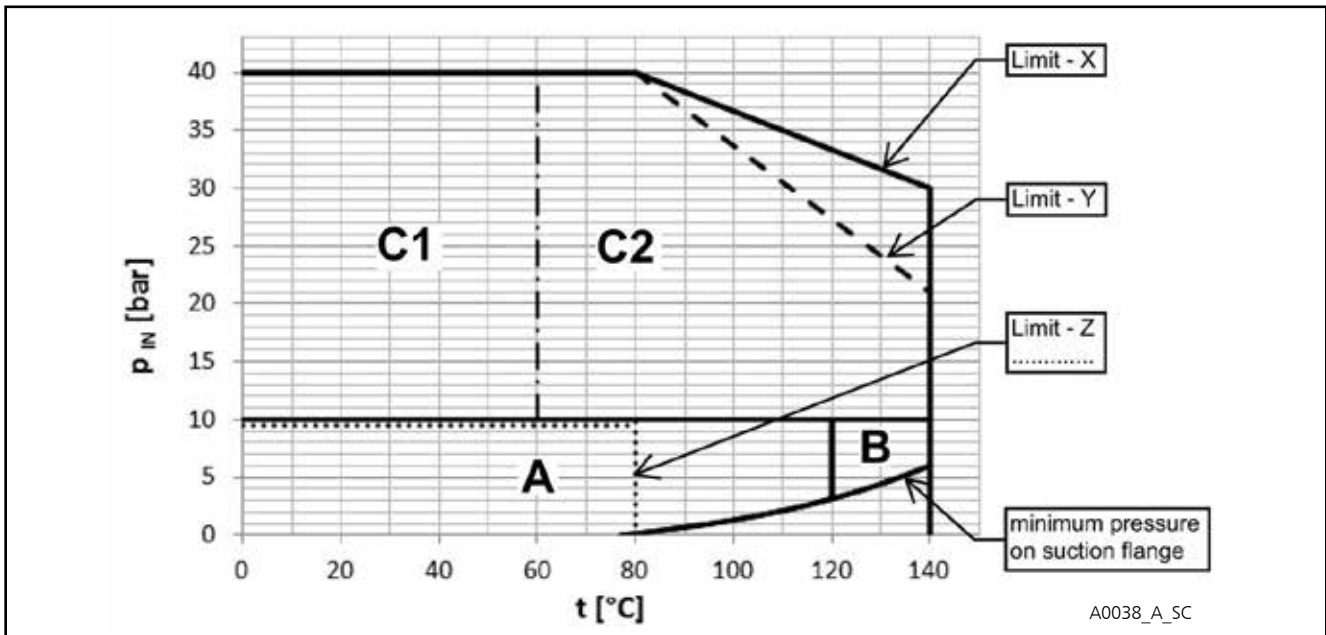

P_{IN}Pump inlet pressure at suction flange [bar]

AREA	DESCRIPTION	TYPE OF MECHANICAL SEAL
A	up to 10 bar inlet pressure at maximum 120°C Standard mechanical seal: Carbon/SiC/EPDM with drinking water approval	B Q1 E G G-WA (UNBALANCED) *
B	up to 10 bar inlet pressure and more than 120°C (maximum 140°C) Standard mechanical seal: Tungsten Carbide/Carbon/EPDM	U3 A E G G (UNBALANCED) *
C1	up to 40 bar inlet pressure at maximum 60°C Standard mechanical seal: Carbon/SiC/EPDM with drinking water approval	B Q1 E G G-WA (BALANCED)
C2	up to 40 bar inlet pressure at maximum 140°C (see limits) Standard mechanical seal: Carbon/SiC/EPDM	A Q1 E G G (BALANCED)

*) ... only for size 50 to 125

MP_Mech_Seal-en_a_td

LIMIT CURVES DEPENDING ON PUMP HYDRAULICS AND MOTOR SPEED

Pump size	Speed (rpm)			
	3600	3000	1800	1500
50	X	X	X	X
65	X	X	X	X
100	Y	X	X	X
125	Y	Y	X	X
150	n/a	Y	X	X

NOTE. Limit - Z ... Limit for material combination SiC/SiC/EPDM (Q1 Q1 E G G) or SiC/SiC/FKM (FPM) (Q1 Q1 V G G)

MP_Limit_Mech_Seal-en_a_td

GENERAL CONSIDERATIONS

This diagram and selection table is valid for clean water (solids < 10 mg/l) or water for feeding boilers, partially or totally demineralized.

If the water temperature exceeds 80 °C, minimum inlet pressure must be guaranteed.

e-MP SERIES

**PRESSURE / TEMPERATURE LIMITS FOR PUMP FLANGES
ACCORDING TO EN 1092 AND CASING MATERIAL**

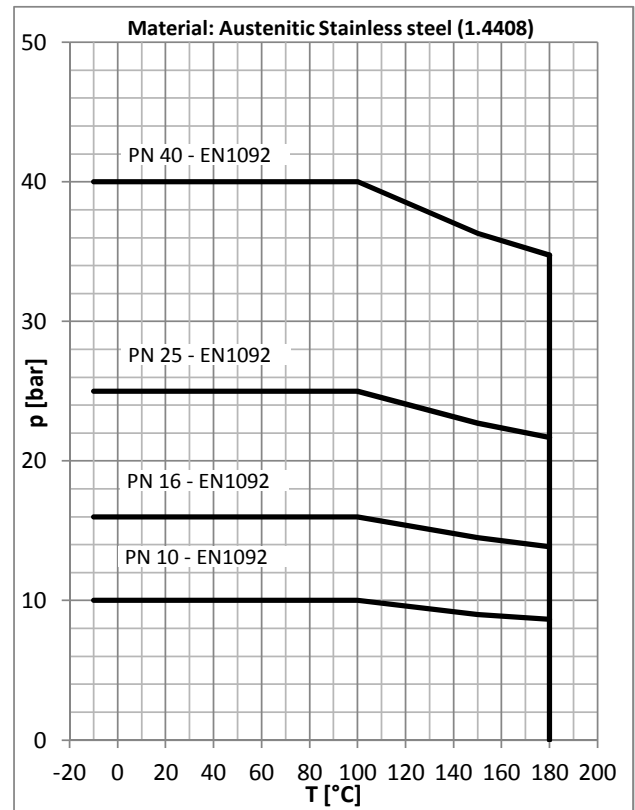
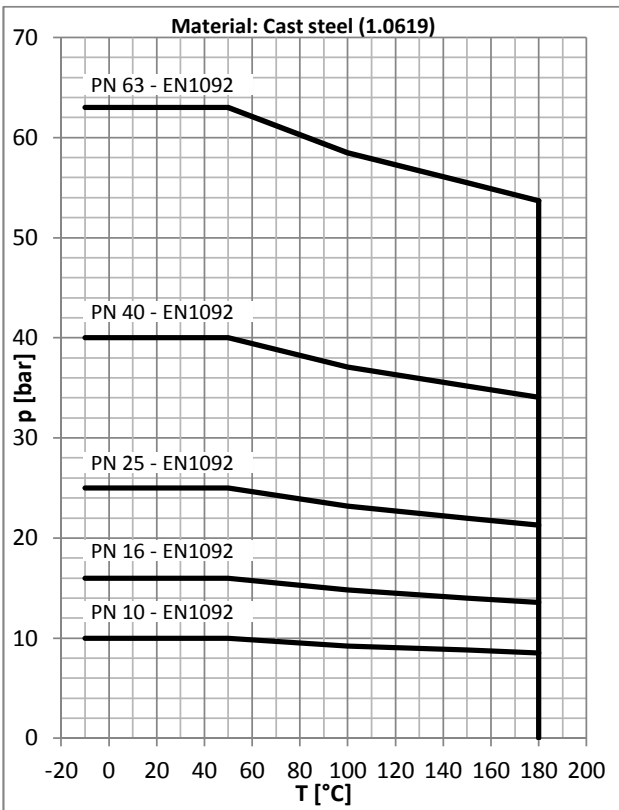
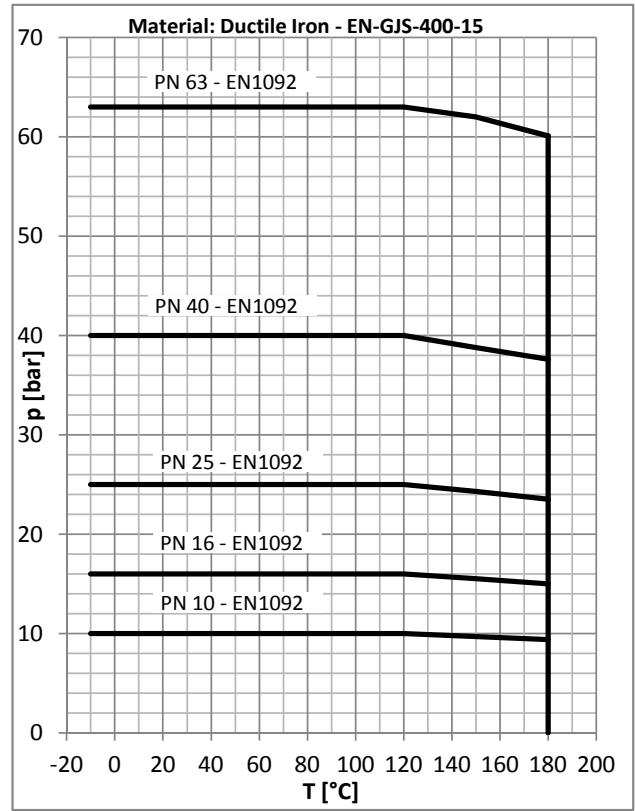
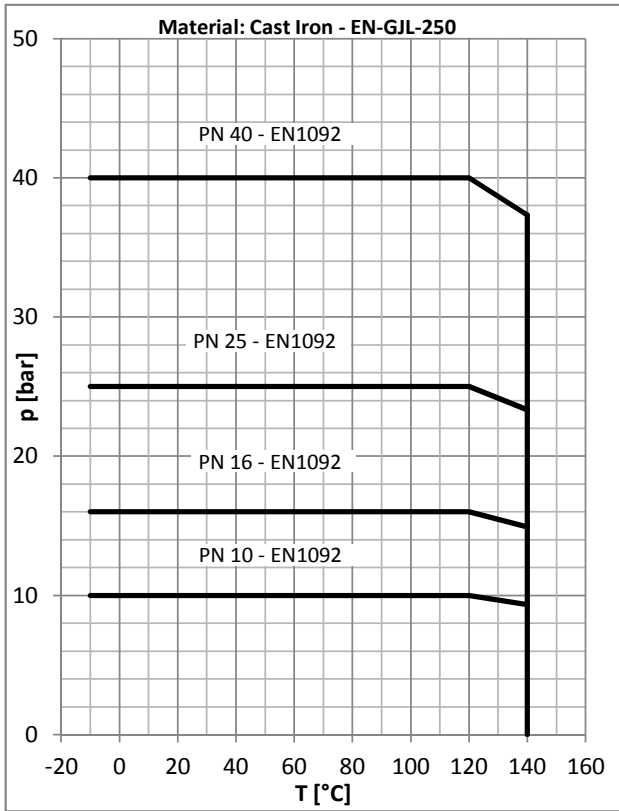

e-MP SERIES

**PRESSURE / TEMPERATURE LIMITS FOR PUMP FLANGES
ACCORDING TO ASME B16.5 AND CASING MATERIAL**

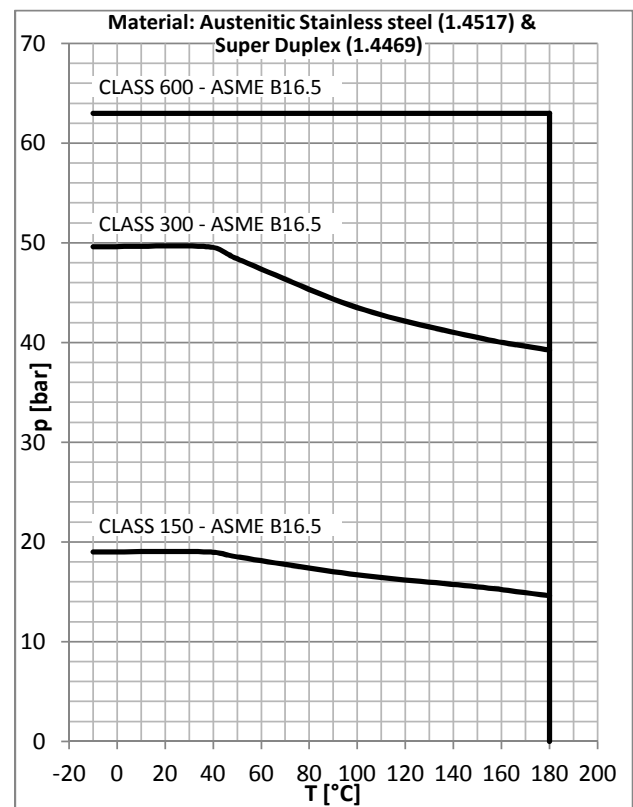
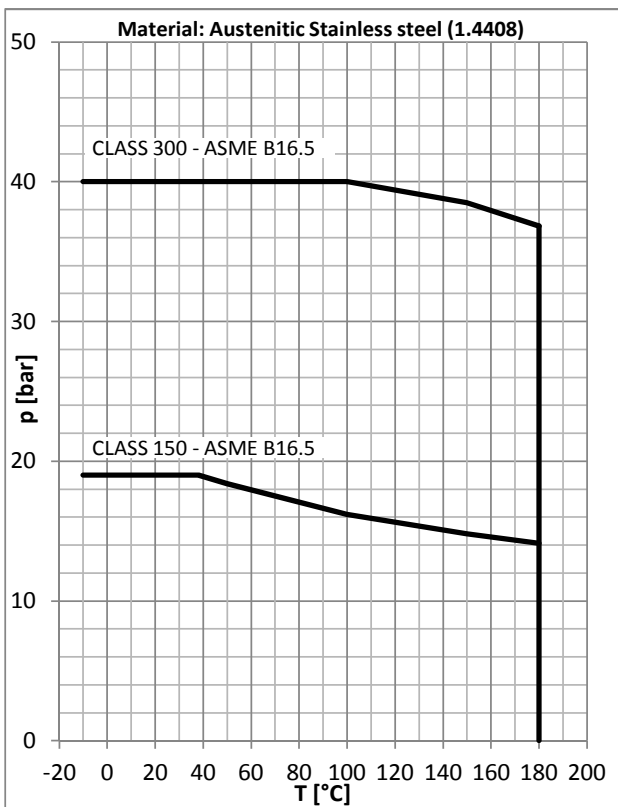
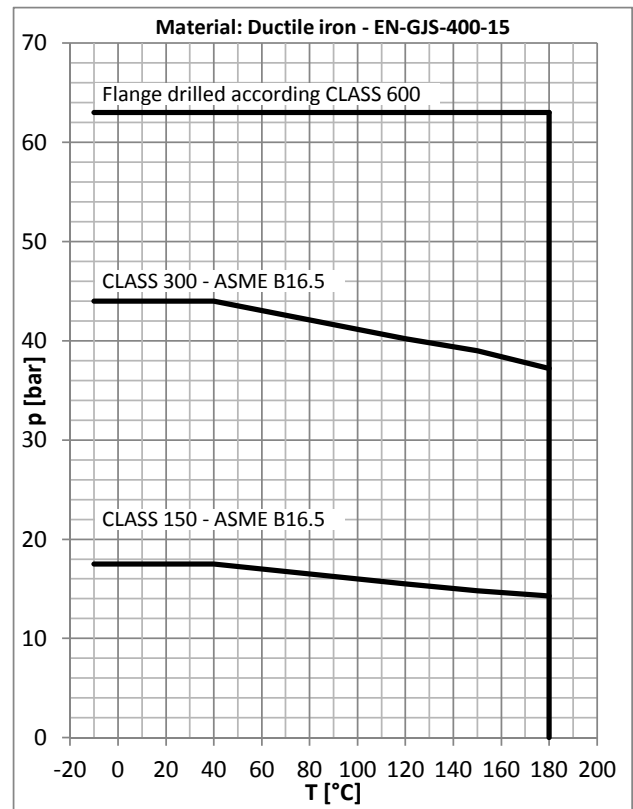
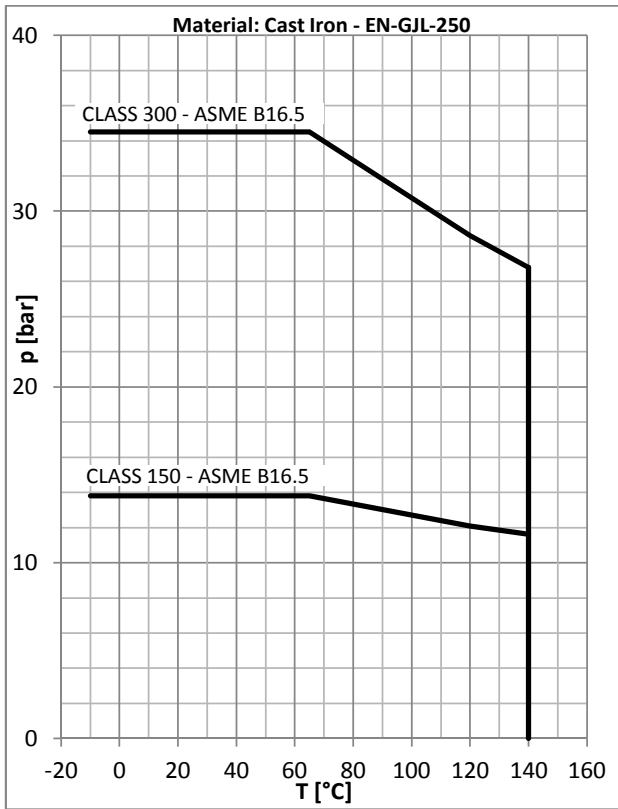

**e-MP SERIES
MOTORS**

With the “Energy using Products” (EuP 2005/32/EC) and “Energy related Products” (ErP 2009/125/EC) directives, the European Commission has established requirements for promoting the use of products with low power consumption.

The various products considered include **three-phase 50 Hz surface motors with power outputs ranging from 0,75 to 375 kW**, also when integrated with other products, with characteristics as defined by the specific **Regulations (EC) No 640/2009** and **(EU) No 4/2014** implementing the requirements of the EuP and ErP Directives.

In accordance with regulations, the **three-phase 50 Hz surface motors with power outputs ranging from 0,75 to 375 kW** have IE3 as minimum level of efficiency or IE2 fitted with variable speed drive. IE2 motor can be supplied without frequency converter as the obligation to have that device is related to when the motor is working and not when placed on the market.

- Short-circuit squirrel-cage motor, enclosed construction with external ventilation (TEFC).
- Rated power from 5,5 to 1250 kW for 2-pole range and from 2,2 to 250 kW for 4-pole range.
- **IP55** protection degree.
- Insulation class **155 (F)**.
- **Standard** three-phase surface motors $\geq 0,75$ kW and < 375 kW supplied as **IE3**.
- IE efficiency level according to EN 60034-30:2009 and EN 60034-30-1:2014 ($\geq 0,75$ kW and < 375 kW).
- Electrical performances according to EN 60034-1.
- Metric cable gland according to EN 50262.
- **Standard voltage**
Three-phase version:
220-240/380-415 V 50 Hz for power up to 3 kW.
380-415/660-690 V 50 Hz for power above 3 kW.
Overload protection to be provided by the user.
- **PTC included** as standard only for WEG motors (one per phase, 155°C).
- Maximum ambient temperature: 40 °C.

e-MP SERIES
THREE-PHASE MOTORS AT 50 Hz, 2 POLES (from 5,5 to 18,5 kW)

P _N kW	Efficiency η_N %									IE
	Δ 380 V Y 660 V			Δ 400 V Y 690 V			Δ 415 V			
	4/4	3/4	2/4	4/4	3/4	2/4	4/4	3/4	2/4	
5,5	90,2	90,5	89,5	90,3	90,2	88,8	90,1	89,8	88,0	3
7,5	90,6	91,0	90,2	90,8	90,8	89,6	90,7	90,5	89,0	
11	91,8	92,3	91,9	92,2	92,5	91,8	92,3	92,4	91,5	
15	92,7	93,3	92,9	93,1	93,3	92,7	92,5	92,4	91,2	
18,5	92,6	93,2	93,0	92,9	93,3	92,8	92,9	93,1	92,4	

P _N kW	Manufacturer		IEC SIZE	Construction Design	N. of Poles	f _N Hz	Data for 400 V / 50 Hz Voltage				
	Xylem Service Italia Srl Reg. No. 07520560967 Montecchio Maggiore Vicenza - Italia						cos ϕ	I _s / I _N	T _N Nm	T _s /T _N	T _m /T _N
	Model										
5,5	PLM132		132	MIPV / MPD - B3 MPV - B5	2	50	0,83	10,0	17,9	3,3	4,7
7,5	PLM132		132				0,85	10,2	24,4	3,4	4,8
11	PLM160		160				0,88	8,6	35,6	2,4	4,1
15	PLM160		160				0,88	9,5	48,6	2,7	4,3
18,5	PLM160		160				0,88	9,8	59,9	2,8	4,5

P _N kW	Voltage U _N V					n _N min ⁻¹	Operating conditions **			
	Δ			Y			Altitude Above Sea Level (m)	T. amb min/max °C	ATEX	
	380 V	400 V	415 V	660 V	690 V					
	I _N (A)									
5,5	10,7	10,6	10,7	6,2	6,1	~2925	See note.	≤ 1000	-15 /+ 40	No
7,5	14,4	14,1	14,2	8,3	8,2	~2920				
11	20,4	19,6	19,2	11,8	11,3	~2935				
15	27,5	26,6	26,1	15,9	15,3	~2940				
18,5	34,0	33,0	32,7	19,6	19,0	~2940				

** Operating conditions to be referred to motor only. About electric pump, refer to limits in user's manual.

eMP-mot_5_5-18_5-en_a_te

Note: Observe the regulations and codes locally in force regarding sorted waste disposal.

e-MP SERIES

THREE-PHASE MOTORS AT 50 Hz, 2 POLES (from 22 to 200 kW)

P _N kW	Efficiency η_N %									IE
	Δ 380 V Y 660 V			Δ 400 V Y 690 V			Δ 415 V			
	4/4	3/4	2/4	4/4	3/4	2/4	4/4	3/4	2/4	
22	92,7	92,7	92,4	92,9	93,0	92,3	92,7	92,8	92,0	3
30	93,3	93,2	92,6	93,5	93,2	92,2	93,3	93,0	91,8	
37	93,7	93,6	93,0	93,8	93,4	92,6	93,7	93,2	92,0	
45	94,0	94,0	93,8	94,2	94,5	94,2	94,3	94,0	94,0	
55	94,3	94,3	93,8	94,4	94,4	93,6	94,4	94,3	93,4	
75	94,7	94,7	93,9	94,9	94,8	93,7	94,9	94,7	93,5	
90	95,0	95,0	94,5	95,2	95,2	94,3	95,2	95,2	94,2	
110	95,4	95,4	94,6	95,4	95,3	94,3	95,4	95,2	94,1	
132	95,6	95,5	94,7	95,6	95,4	94,5	95,6	95,4	94,3	
160	95,8	95,8	95,3	95,8	95,8	95,1	95,8	95,8	94,9	
200	96,0	96,2	95,8	96,0	96,2	95,7	96,0	96,2	95,6	

P _N kW	Manufacturer		IEC SIZE	Construction Design	N. of Poles	f _N Hz	Data for 400 V / 50 Hz Voltage				
	WEG Equipamentos Elétricos S.A. Reg. No. 07.175.725/0010-50 Jaraguá do Sul - SC (Brazil)						cos ϕ	I _s / I _N	T _N Nm	T _s /T _N	T _m /T _N
	Model										
22	W22 180M	180	MPA/ MPV/ MPD - B3 MPV - B5	2	50	0,86	8,3	71	2,7	3,6	
30	W22 200L	200				0,85	7,7	97	3,0	3,0	
37	W22 200L	200				0,84	7,7	119	3,1	3,0	
45	W22 225S/M	225				0,89	7,7	145	2,4	3,1	
55	W22 250S/M	250				0,88	7,8	178	2,7	3,3	
75	W22 280S/M	280				0,88	7,5	241	2,0	3,1	
90	W22 280S/M	280				0,89	7,6	289	2,1	3,1	
110	W22 315S/M	315				0,88	7,5	353	1,9	3,0	
132	W22 315S/M	315				0,89	7,6	423	2,1	3,1	
160	W22 315S/M	315				0,89	7,4	513	2,0	2,9	
200	W22 315L	315				0,90	7,6	642	2,3	2,9	

P _N kW	Voltage U _N V					n _N min ⁻¹	Operating conditions **		
	Δ			Y			Altitude Above Sea Level (m)	T. amb min/max °C	ATEX
	380 V	400 V	415 V	660 V	690 V				
	I _N (A)								
22	41,4	39,7	39,3	23,9	22,9	~2950	See note: ≤ 1000	-15 /+ 40	No
30	56,2	54,5	54,6	32,4	31,5	~2960			
37	69,0	67,8	67,0	39,8	39,1	~2960			
45	80,8	77,5	75,4	46,6	44,7	~2960			
55	98,5	95,6	93,2	56,9	55,2	~2960			
75	135,0	130,0	126,0	77,9	75,1	~2975			
90	162,0	153,0	149,0	93,5	88,3	~2975			
110	197,0	189,0	184,0	113,7	109,1	~2980			
132	233,0	224,0	218,0	134,5	129,3	~2980			
160	282,0	271,0	264,0	162,8	156,5	~2980			
200	348,0	334,0	326,0	200,9	192,8	~2975			

** Operating conditions to be referred to motor only. About electric pump, refer to limits in user's manual.

Note: Observe the regulations and codes locally in force regarding sorted waste disposal.

e-MP SERIES

THREE-PHASE MOTORS AT 50 Hz, 2 POLES (from 250 to 630 kW)

P _N kW	Efficiency η_N %									IE
	Δ 380 V Y 660 V			Δ 400 V Y 690 V			Δ 415 V			
	4/4	3/4	2/4	4/4	3/4	2/4	4/4	3/4	2/4	
250	96,0	96,0	96,4	96,0	96,2	95,7	96,0	96,2	95,6	3
315	96,0	96,0	95,0	96,0	96,0	95,5	95,8	95,6	95,2	
355	95,8	95,5	95,3	95,8	95,6	95,3	95,8	95,6	95,3	
400	96,3	96,2	95,9	96,4	96,2	95,8	96,5	96,2	95,7	
450	96,4	96,2	95,9	96,4	96,2	95,8	96,4	96,2	95,7	
500	-	-	-	96,6	96,5	95,8	-	-	-	
560	-	-	-	96,6	96,5	5,8	-	-	-	
630	-	-	-	96,7	96,6	96,0	-	-	-	

P _N kW	Manufacturer		IEC SIZE	Construction Design	N. of Poles	f _N Hz	Data for 400 V / 50 Hz Voltage				
	WEG Equipamentos Elétricos S.A. Reg. No. 07.175.725/0010-50 Jaraguá do Sul - SC (Brazil)						cos ϕ (4/4)	I _s / I _N	T _N Nm	T _s /T _N	T _m /T _N
	Model										
250	W22 315L		315	MPA/MPR/MPD - B3 MPV - B5	2	50	0,91	7,8	802	2,7	2,9
315	W22 355M/L		355				0,91	7,7	1010	2,1	2,5
355	W22 355M/L		355				0,91	7,9	1136	2,2	2,8
400	W22 355A/B		355				0,91	7,6	1280	2,4	2,8
450	W22 355A/B		355				0,91	7,5	1440	2,5	2,7
500	W50 400J/H		400				0,90	7,1	1603	1,3	2,5
560	W50 400J/H		400				0,90	7,1	1793	1,3	2,5
630	W50 400J/H		400				0,91	7,5	2020	1,3	2,5

P _N kW	Voltage U _N V					n _N min ⁻¹	Operating conditions **			
	Δ			Y			See note.	Altitude Above Sea Level (m)	T. amb min/max °C	ATEX
	380 V	400 V	415 V	660 V	690 V					
	I _N (A)									
250	430	413	398	248	238	~2980	≤ 1000	-15 /+ 40	No	
315	542	520	497	313	300	~2980				
355	619	588	567	357	339	~2985				
400	694	658	634	401	380	~2985				
450	779	740	714	450	427	~2985				
500	-	830	-	-	479	~2980				
560	-	930	-	-	537	~2980				
630	-	1030	-	-	595	~2980				

** Operating conditions to be referred to motor only. About electric pump, refer to limits in user's manual.

eMP-mot_250-630-en_a_te

Note: Observe the regulations and codes locally in force regarding sorted waste disposal.

e-MP SERIES

THREE-PHASE MOTORS AT 50 Hz, 2 POLES (from 710 to 1250 kW)

P _N kW	Efficiency η_N %									IE
	Y 3000 V			4/4	3/4	2/4	4/4	3/4	2/4	
	4/4	3/4	2/4							
710	96,5	96,5	96,0							n/a
800	96,6	96,6	96,1							
900	96,7	96,7	96,1							
1000	96,7	96,7	96,1							
1100	96,0	95,9	95,1							
1250	96,2	96,1	95,4							

P _N kW	Manufacturer		IEC SIZE	Construction Design	N. of Poles	f _N Hz	Data for 3000 V / 50 Hz Voltage				
	WEG Equipamentos Elétricos S.A. Reg. No. 07.175.725/0010-50 Jaragua do Sul - SC (Brazil)						cos ϕ (4/4)	I _s / I _N	T _N Nm	T _s /T _N	T _m /T _N
	Model										
710	W50 - 450J/H		450	MPA/MPR/MPD - B3	2	50	0,88	6,5	2272	0,7	2,5
800	W50 - 450J/H		450				0,90	6,3	2562	0,7	2,5
900	W50 - 450J/H		450				0,90	6,5	2883	0,7	2,5
1000	W50 - 450J/H		450				0,88	6,5	3196	0,9	2,5
1100	HGF - 500		500				0,89	7,0	3516	0,7	2,5
1250	HGF - 500		500				0,89	7,0	3995	0,7	2,5

P _N kW	Voltage U _N V				n _N min ⁻¹	Operating conditions **			
	Δ		Y			Altitude Above Sea Level (m)	T. amb min/max °C	ATEX	
			3000 V						
	I _N (A)					See note.	≤ 1000	-15 /+ 40	No
710			161		~2985				
800			177		~2982				
900			199		~2981				
1000			227		~2988				
1100			248		~2988				
1250			281		~2988				

** Operating conditions to be referred to motor only. About electric pump, refer to limits in user's manual.

Note: Observe the regulations and codes locally in force regarding sorted waste disposal.

e-MP SERIES

THREE-PHASE MOTORS AT 50 Hz, 4 POLES (from 2,2 to 15 kW)

P _N kW	Efficiency η_N %									IE
	Δ 380 V Y 660 V			Δ 400 V Y 690 V			Δ 415 V			
	4/4	3/4	2/4	4/4	3/4	2/4	4/4	3/4	2/4	
2,2	87,6	88,6	87,4	87,6	88,6	87,4	87,6	88,6	87,4	3
3	88,5	88,6	86,8	88,5	88,6	86,8	88,5	88,6	86,8	
4	88,6	89,2	88,9	88,6	89,2	88,4	88,8	89,1	87,9	
5,5	90,4	91,0	90,5	90,9	91,1	90,2	90,9	90,9	89,7	
7,5	90,4	91,2	91,1	90,7	91,3	90,8	90,9	91,2	90,4	
11	91,5	92,4	92,4	91,9	92,5	92,0	91,9	92,2	91,4	
15	92,5	93,0	92,7	92,5	92,7	91,8	92,2	92,2	90,8	

P _N kW	Manufacturer		IEC SIZE	Construction Design	N. of Poles	f _N Hz	Data for 400 V / 50 Hz Voltage				
	Xylem Service Italia Srl Reg. No. 07520560967 Montecchio Maggiore Vicenza - Italia						cos ϕ	I _s / I _N	T _N Nm	T _s /T _N	T _m /T _N
2,2	Model		100	MPV - B3 MPV - B5	4	50	0,78	7,5	14,5	2,4	3,7
3	PLM4100		100				0,74	7,8	19,7	2,5	4,2
4	PLM4112		112				0,79	8,3	26,3	3,2	4,0
5,5	PLM4132		132				0,76	7,6	35,9	2,9	3,7
7,5	PLM4132		132				0,79	7,7	49,1	2,7	3,6
11	PLM4160		160				0,81	7,2	71,5	2,5	3,3
15	PLM4160		160				0,77	8,2	97,2	3,0	4,0

P _N kW	Voltage U _N V					n _N min ⁻¹	Operating conditions **		
	Δ			Y			Altitude Above Sea Level (m)	T. amb min/max °C	ATEX
	380 V	400 V	415 V	660 V	690 V				
	I _N (A)								
2,2	4,7	4,6	4,6	2,7	2,7	~1450	See note. ≤ 1000	-15 /+ 40	No
3	6,6	6,6	6,6	3,8	3,8	~1455			
4	8,4	8,2	8,2	4,9	4,8	~1450			
5,5	11,7	11,5	11,4	6,8	6,6	~1460			
7,5	15,5	15,2	15,1	9,0	8,8	~1455			
11	21,9	21,4	21,3	12,6	12,3	~1465			
15	30,5	30,7	31,4	17,6	17,7	~1470			

** Operating conditions to be referred to motor only. About electric pump, refer to limits in user's manual.

eMP-mot2_2-15-en_a_te

Note: Observe the regulations and codes locally in force regarding sorted waste disposal.

e-MP SERIES

THREE-PHASE MOTORS AT 50 Hz, 4 POLES (from 18,5 to 250 kW)

P _N kW	Efficiency η_N %									IE
	Δ 380 V Y 660 V			Δ 400 V Y 690 V			Δ 415 V			
	4/4	3/4	2/4	4/4	3/4	2/4	4/4	3/4	2/4	
18,5	93,1	92,9	92,5	93,3	92,9	92,2	93,4	92,8	91,8	3
22	93,4	93,1	92,8	93,6	93,0	92,4	93,6	92,8	91,9	
30	94,1	94,1	93,5	94,2	94,0	93,0	94,2	93,9	92,5	
37	94,3	94,5	94,1	94,6	94,6	94,0	94,7	94,6	93,8	
45	94,7	94,7	94,3	94,8	94,8	94,2	94,8	94,8	94,0	
55	95,1	94,9	94,7	95,3	95,0	94,6	95,4	94,9	94,4	
75	95,4	95,2	94,8	95,6	95,2	94,7	95,7	95,2	94,6	
90	95,6	95,4	95,1	95,8	95,5	95,0	95,9	95,5	94,9	
110	96,2	95,9	95,5	96,3	95,9	95,4	96,3	95,8	95,2	
132	96,3	96,0	95,6	96,4	96,0	95,5	96,4	95,9	95,3	
160	96,3	96,2	95,8	96,5	96,2	95,7	96,6	96,2	95,5	
200	96,5	96,5	96,2	96,7	96,5	96,1	96,7	96,5	95,9	
250	96,8	96,6	96,4	96,9	96,6	96,2	96,9	96,5	96,0	

P _N kW	Manufacturer		IEC SIZE	Construction Design	N. of Poles	f _N Hz	Data for 400 V / 50 Hz Voltage				
	WEG Equipamentos Eletricos S.A. Reg. No. 07.175.725/0010-50 Jaragua do Sul - SC (Brazil)						cos ϕ	I _s / I _N	T _N Nm	T _s /T _N	T _m /T _n
	Model										
18,5	W22 180M4		180	MPA/MPRV/MPD - B3 MPV - B5	4	50	0,82	7,30	120	2,70	3,00
22	W22 180L4		180				0,83	7,30	143	2,80	3,30
30	W22 200L4		200				0,82	7,30	194	2,50	3,00
37	W22 225S/M4		225				0,86	7,80	239	2,70	3,00
45	W22 225S/M4		225				0,85	7,90	290	2,80	3,20
55	W22 250S/M4		250				0,86	7,90	355	2,80	3,30
75	W22 280S/M4		280				0,87	7,60	482	2,30	2,80
90	W22 280S/M4		280				0,86	7,40	579	2,30	2,80
110	W22 315S/M4		315				0,86	7,50	705	2,60	2,70
132	W22 315S/M4		315				0,86	7,60	846	2,90	3,00
160	W22 315S/M4		315				0,87	7,60	1025	2,60	2,60
200	W22 315L4		315				0,87	7,60	1282	2,50	2,50
250	W22 315L4		315				0,86	8,00	1602	2,70	2,60

P _N kW	Voltage U _N V					n _N min ⁻¹	Operating conditions **			
	Δ			Y			Altitude Above Sea Level (m)	T. amb min/max °C	ATEX	
	380 V	400 V	415 V	660 V	690 V					
	I _N (A)									
18,5	35,90	34,90	34,40	20,70	20,20	~1470	See note	≤ 1000	-20 / +40	No
22	42,10	40,90	40,40	24,20	23,70	~1470				
30	57,70	56,10	55,40	33,20	32,50	~1480				
37	68,50	65,60	63,90	39,40	38,00	~1480				
45	83,90	79,40	78,60	48,30	46,00	~1480				
55	100,0	96,90	94,40	57,60	56,20	~1480				
75	136,0	130,0	127,0	78,30	75,40	~1485				
90	164,0	158,0	154,0	94,40	91,60	~1485				
110	200,0	192,0	187,0	115,0	111,0	~1490				
132	239,0	230,0	224,0	138,0	133,0	~1490				
160	287,0	275,0	268,0	165,0	159,0	~1490				
200	358,0	343,0	335,0	206,0	199,0	~1490				
250	451,0	433,0	422,0	260,0	251,0	~1490				

** Operating conditions to be referred to motor only. About electric pump, refer to limits in user's manual.

Note: Observe the regulations and codes locally in force regarding sorted waste disposal.

NOISE LEVEL

The tables below show the mean sound pressure levels (L_p) measured at 1 meter's distance in a free field according to the A curve (ISO 1680 standard).

The noise values are indicated with a tolerance of 3 dB (A).

NOISE LEVEL OF PUMP WITH STANDARD MOTOR

POWER [kW]	SOUND PRESSURE LEVEL L _p A [dB(A)]			
	SPEED [min ⁻¹]			
	2950	1450	3550	1750
2,2	63,2	57,9	65,7	58,4
3	67,6	59,0	70,3	59,5
4	65,5	60,8	67,8	61,3
5,5	68,1	61,8	70,6	62,3
7,5	68,4	63,0	70,8	63,4
11	69,0	65,6	71,2	66,2
15	69,6	66,7	71,6	67,2
18,5	70,1	67,4	71,9	67,9
22	70,6	68,1	72,2	68,5
30	73,9	69,7	76,1	70,1
37	74,3	70,5	76,4	70,9
45	75,9	71,2	78,1	71,6
55	76,3	72,1	78,3	72,5
75	78,7	74,4	81,0	74,9
90	79,0	75,0	81,2	75,5
110	79,4	76,2	81,4	76,8
132	79,8	76,9	81,7	77,3
160	80,2	77,6	82,0	78,0
200	81,3	78,9	83,0	79,3
250	81,8	79,7	83,5	80,0
315	83,3		85,1	81,1
355	83,7		85,3	81,6
400	85,5		87,5	82,5
450	85,7		87,6	
500	84,0		85,2	
560	84,5		85,5	
630	84,9		85,9	
710	85,8		86,9	
800	86,2		87,2	
900	86,7		87,7	
1000	87,1		88,0	
1100	87,9		89,0	
1250	88,3		89,4	

NOISE LEVEL OF PUMP WITHOUT MOTOR

POWER [kW]	SOUND PRESSURE LEVEL L _p A [dB(A)]			
	SPEED [min ⁻¹]			
	2950	1450	3550	1750
2,2	57,2	56,2	57,4	56,5
3	58,6	57,7	58,9	58,0
4	60,0	59,1	60,2	59,3
5,5	61,5	60,5	61,7	60,8
7,5	62,9	62,0	63,2	62,3
11	64,8	63,8	65,0	64,1
15	66,2	65,3	66,5	65,6
18,5	67,2	66,3	67,5	66,6
22	68,1	67,1	68,3	67,4
30	69,5	68,6	69,8	68,9
37	70,5	69,6	70,8	69,9
45	71,5	70,5	71,7	70,8
55	72,4	71,4	72,6	71,7
75	73,8	72,9	74,1	73,2
90	74,8	73,8	75,0	74,1
110	75,7	74,7	75,9	75,0
132	76,5	75,6	76,7	75,8
160	77,4	76,5	77,6	76,7
200	78,5	77,6	78,7	77,8
250	79,5	78,6	79,8	78,8
315	80,6		80,9	79,9
355	81,2		81,4	80,5
400	81,8		82,0	81,1
450	82,4		82,6	
500	82,8		83,1	
560	83,4		83,6	
630	83,9		84,2	
710	84,5		84,7	
800	85,0		85,2	
900	85,7		85,9	
1000	86,1		86,4	
1100	86,6		86,8	
1250	87,2		87,5	

eMP-noise_a_tr

e-MP SERIES PUMPS

With the “Energy using Products” (EuP 2005/32/EC) and “Energy related Products” (ErP 2009/125/EC) directives, the European Commission has established requirements for promoting the use of products with low power consumption.

The **Commission Regulation (EU) No 547/2012** has implemented two directives with regard to ecodesign requirements for **some types of clean water pumps** placed on the market and put into service inside EU zone as stand-alone units or integrated in other products.

For “*multistage vertical water pumps*” (MS-V for the Regulation) the efficiency assessment refers to:

- just the pump and not the pump and motor assembly (electric or combustion);
- pumps with more than one impeller;
- pumps with impellers mounted on a vertical shaft;
- pumps with a nominal pressure PN not higher than 25 bar (2500 kPa);
- pumps with a maximum nominal flow not greater than 100 m³/h (27,78*10⁻³ m³/s);
- pumps designed to operate at a speed of 2900 rpm (for electric pumps this means 50 Hz 2-pole electric motors);
- use with clean water at a temperature ranging from -10°C to 120°C (the test is performed with cold water at a temperature not higher than 40°C).

According to the definitions established in the Regulation MPV versions correspond to the “multistage vertical pump” while designs MPA, MPD and MPR as well as all MPV with nominal head higher than 25 bar do not fall under this regulation. This regulation states that water pumps shall have a minimum index MEI coming from a dedicated formula which considers hydraulic efficiency values at ‘best efficiency point’ (BEP), 75 % of the flow at BEP (Part load – PL) and 110 % of the flow at BEP (Over load – OL).

The Regulation also establishes the following deadlines.

from	minimum efficiency index (MEI)
1 st January 2015	MEI ≥ 0,4

Regulation (EU) n. 547/2012 – Annex II – point 2 (Product information requirements)

1. Minimum efficiency index: see MEI values in specific table below.
2. “The benchmark for most efficient water pumps is MEI ≥ 0,70”.
3. Year of manufacture: 2017.
4. Manufacturer: Xylem Service Italia Srl - Reg. No 07520560967 - Montecchio Maggiore, Vicenza, Italy.
5. Pump performance curves, including the performance curve: see the Operating Characteristics graphs in the following pages.
6. “The efficiency of a pump with a trimmed impeller is usually lower than that of a pump with the full impeller diameter. The trimming of the impeller will adapt the pump to a fixed duty point, leading to reduced energy consumption. The minimum efficiency index (MEI) is based on the full impeller diameter of a single stage”.
7. “The operation of this water pump with variable duty points may be more efficient and economic when controlled, for example, by the use of a variable speed drive that matches the pump duty to the system”.
8. Information relevant for disassembly, recycling or disposal at end-of-life: observe the current laws and by-laws governing sorted waste disposal. Consult the product operating manual.
9. “Designed for use below – 10 °C only”: note not applicable to these products.
10. “Designed for use above 120 °C only”: note not applicable to these products.
11. Specific instructions for pumps as per points 9 and 10: not applicable to these products.
12. “Information on benchmark efficiency is available at”: www.europump.org (Ecodesign section).
13. The benchmark efficiency graphs with MEI = 0.7 and MEI = 0.4 are available at www.europump.org, Ecodesign, Efficiency charts (refer to “MS-V”).

MINIMUM EFFICIENCY INDEX (MEI)

PUMP SIZE	Minimum efficiency index (MEI)
MPV50A	≥ 0,7
MPV50B	≥ 0,7
MPV65A	≥ 0,7
MPV65B	≥ 0,7

e-MP SERIES

HYDRAULIC PERFORMANCE RANGE AT 50 Hz, 2 POLES

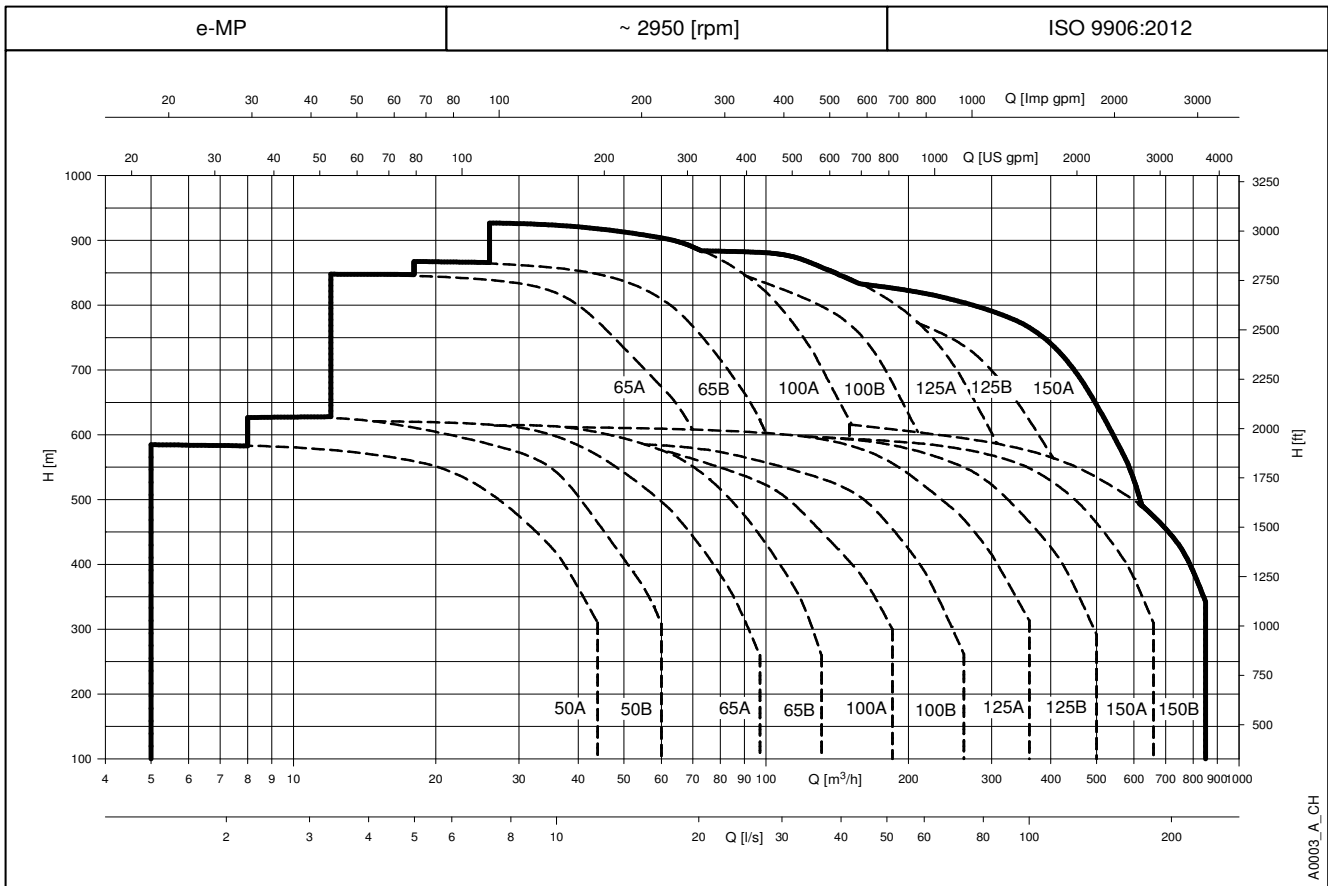

HYDRAULIC PERFORMANCE RANGE AT 50 Hz, 4 POLES

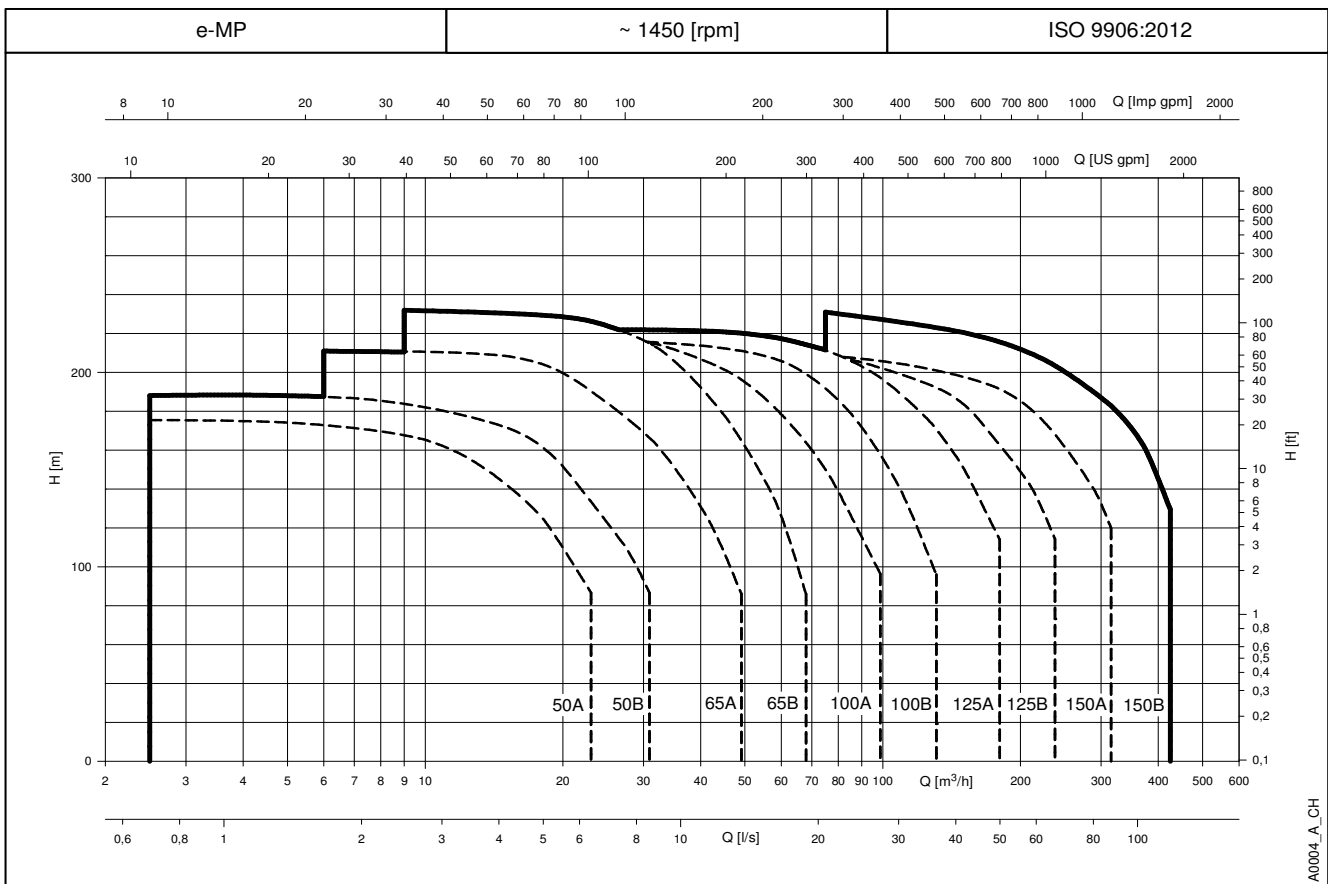

e-MP50A SERIES

OPERATING CHARACTERISTICS AT 50 Hz, 2 POLES

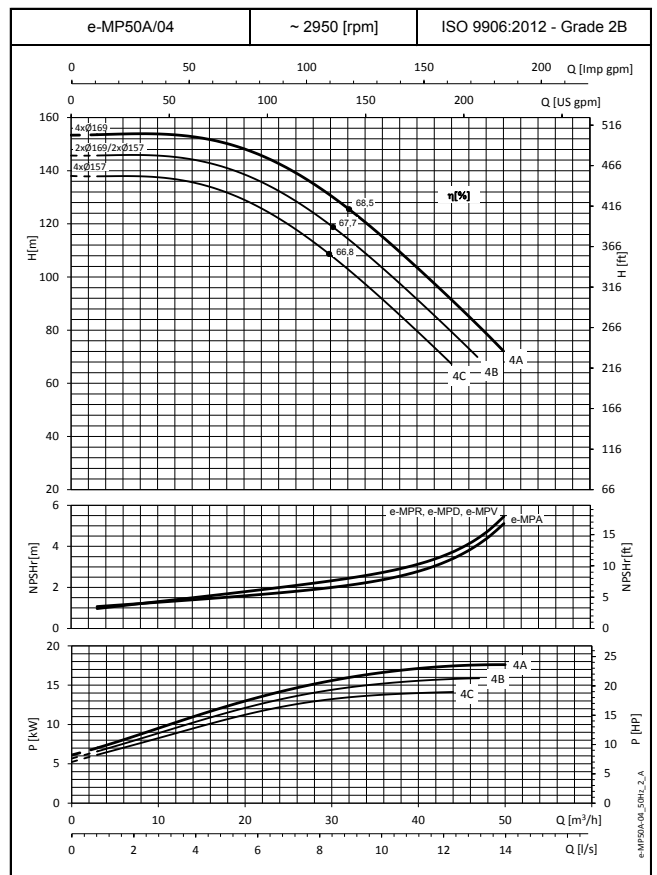
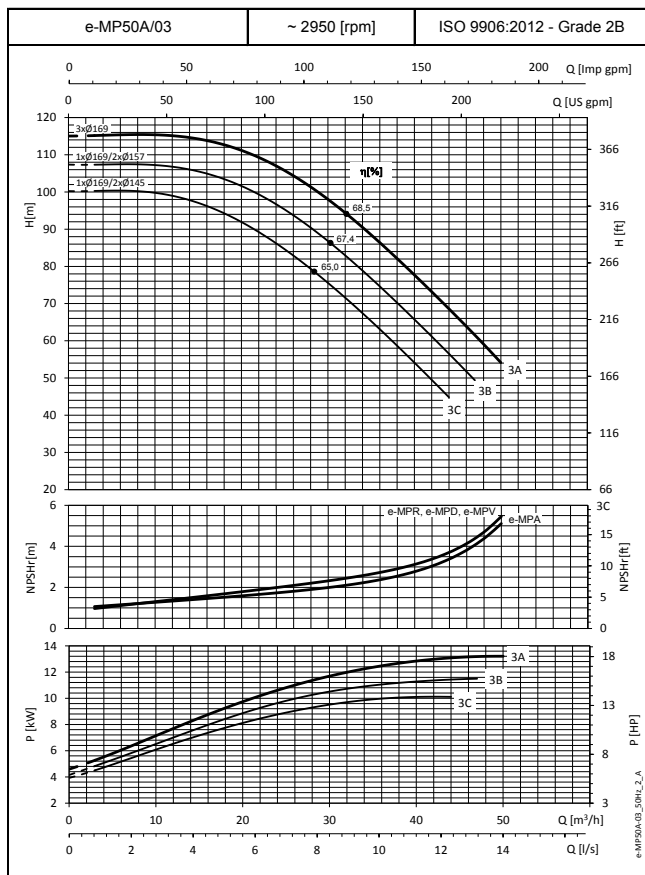
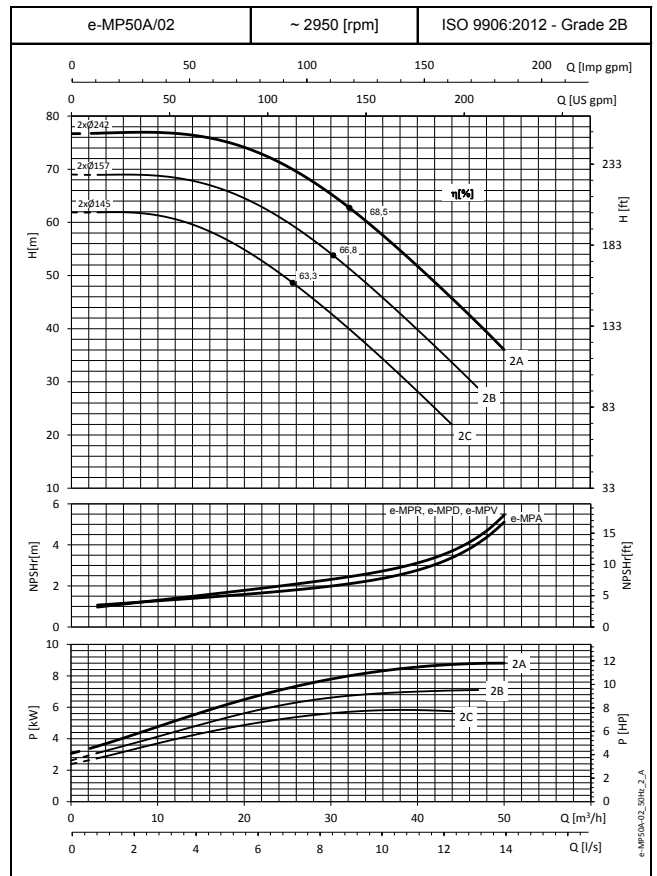
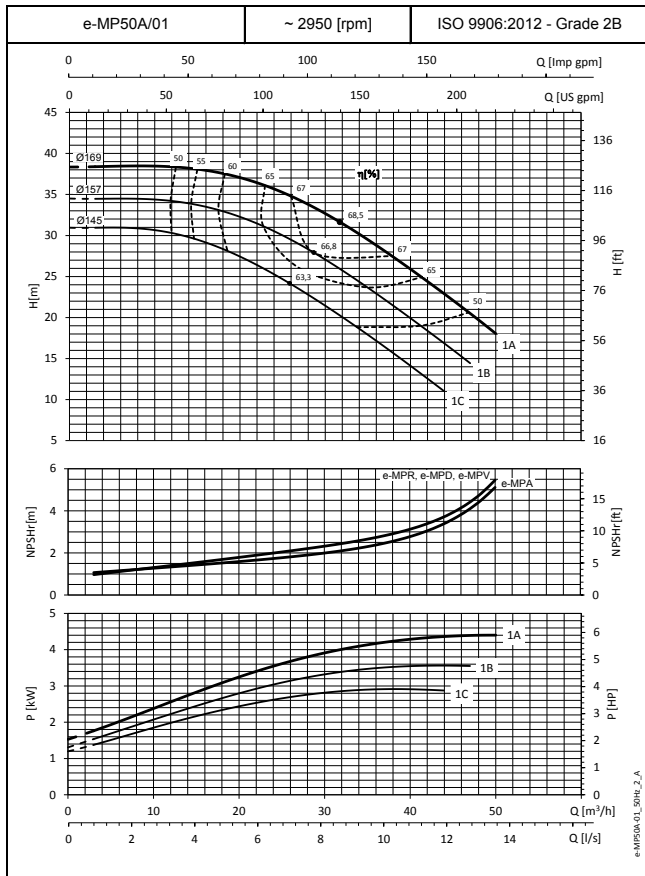

These performances are valid for cold water with density $\rho = 1 \text{ Kg/dm}^3$ and viscosity $\nu = 1 \text{ mm}^2/\text{sec}$.

e-MP50A SERIES

OPERATING CHARACTERISTICS AT 50 Hz, 2 POLES

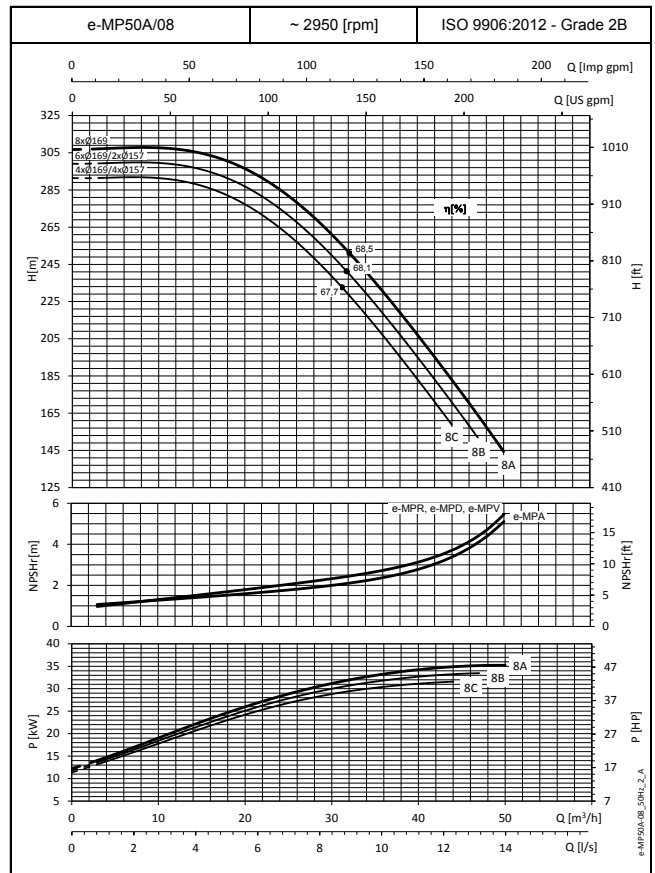
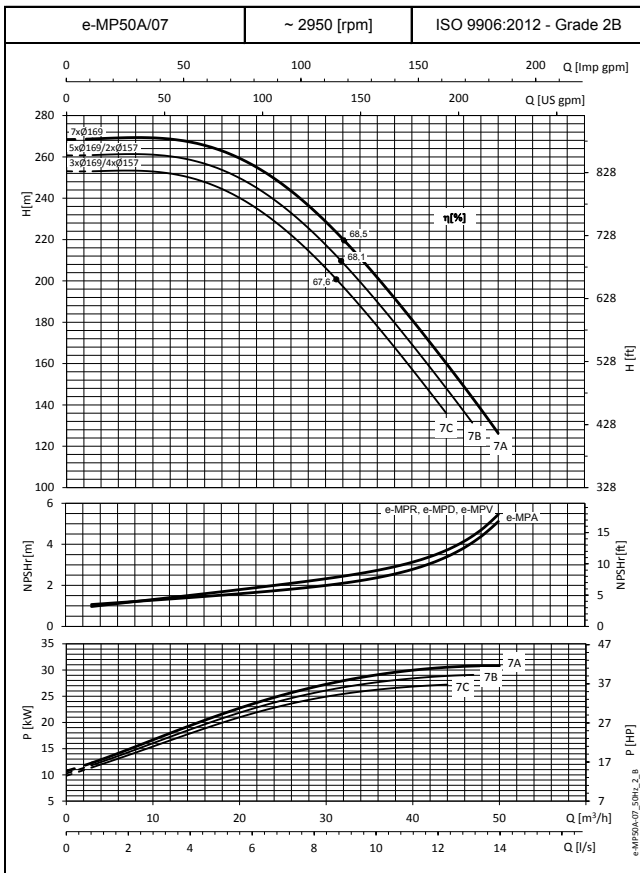
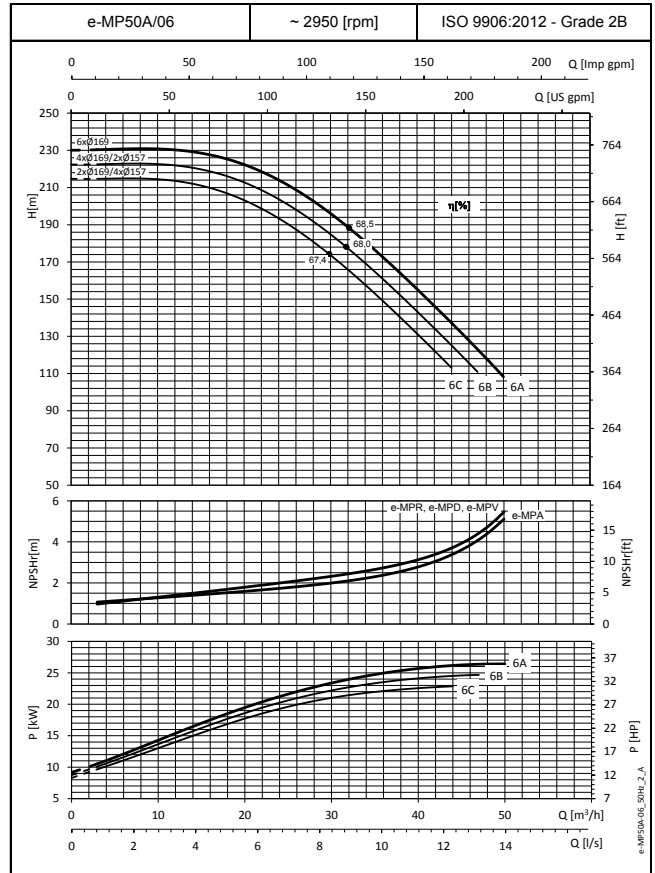
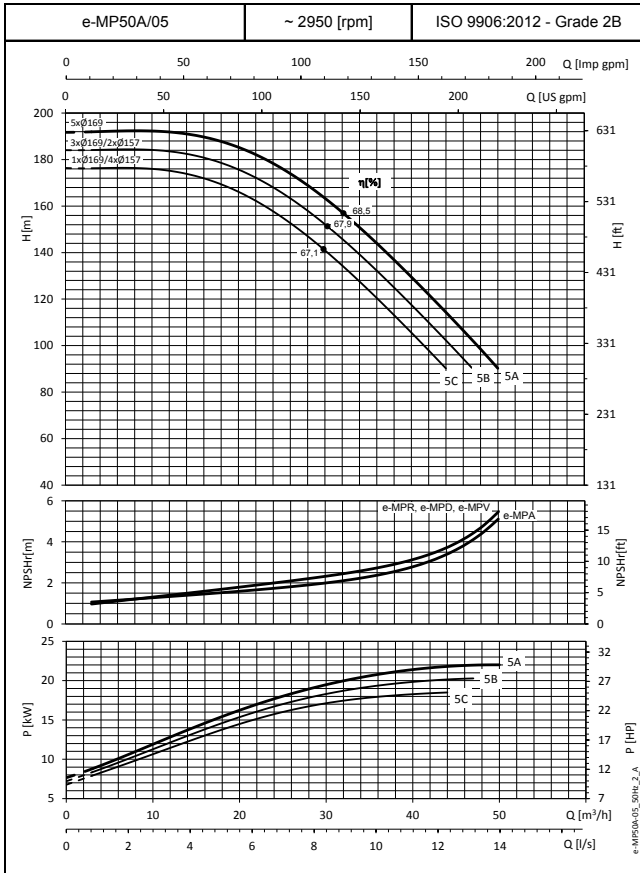

These performances are valid for cold water with density $\rho = 1 \text{ Kg/dm}^3$ and viscosity $\nu = 1 \text{ mm}^2/\text{sec}$.

e-MP50A SERIES

OPERATING CHARACTERISTICS AT 50 Hz, 2 POLES

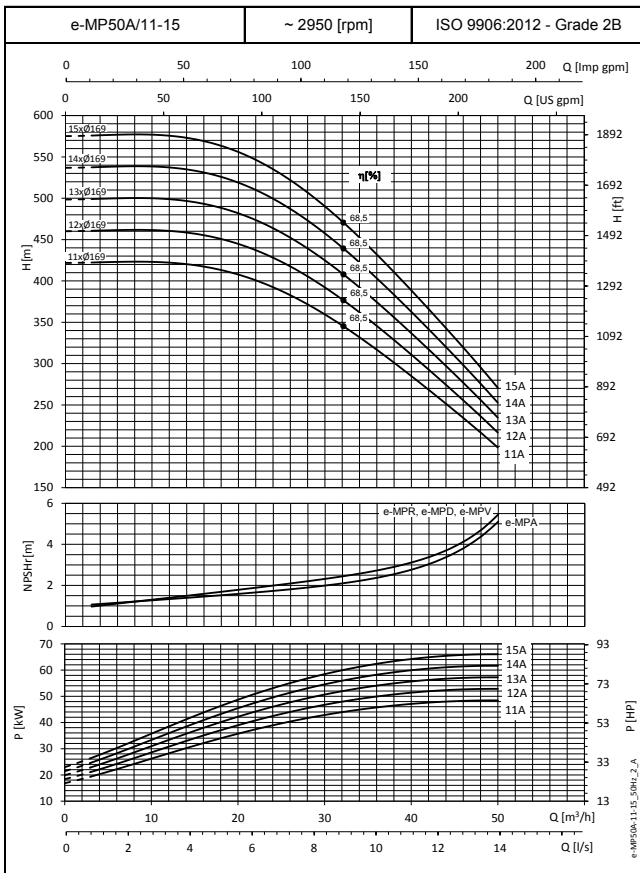
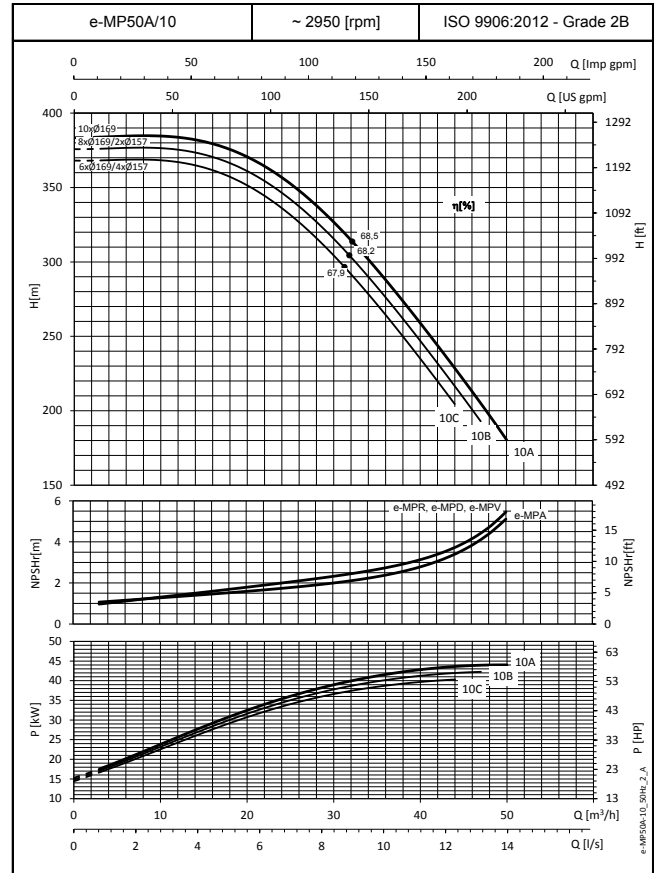
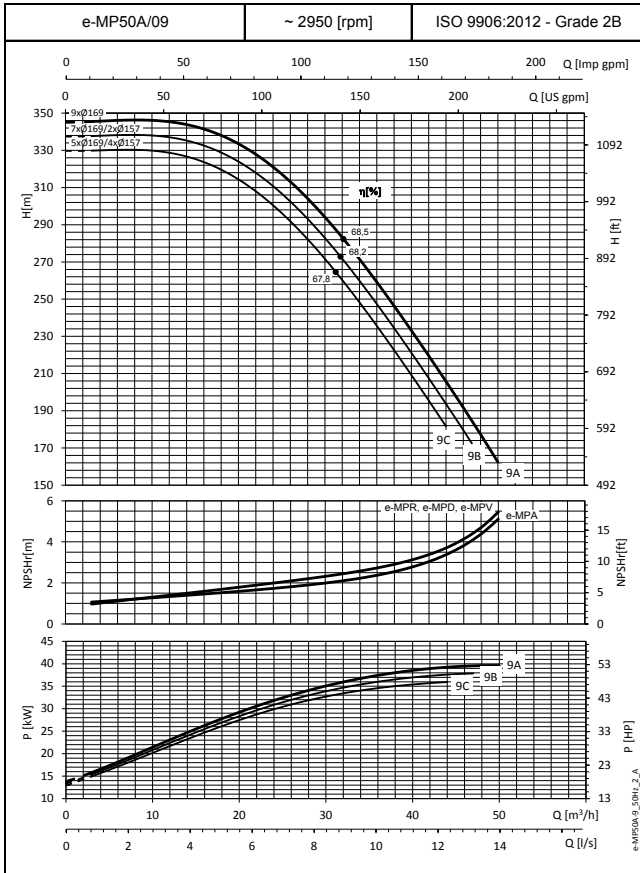

These performances are valid for cold water with density $\rho = 1 \text{ Kg/dm}^3$ and viscosity $\nu = 1 \text{ mm}^2/\text{sec}$.

e-MP50B SERIES

OPERATING CHARACTERISTICS AT 50 Hz, 2 POLES

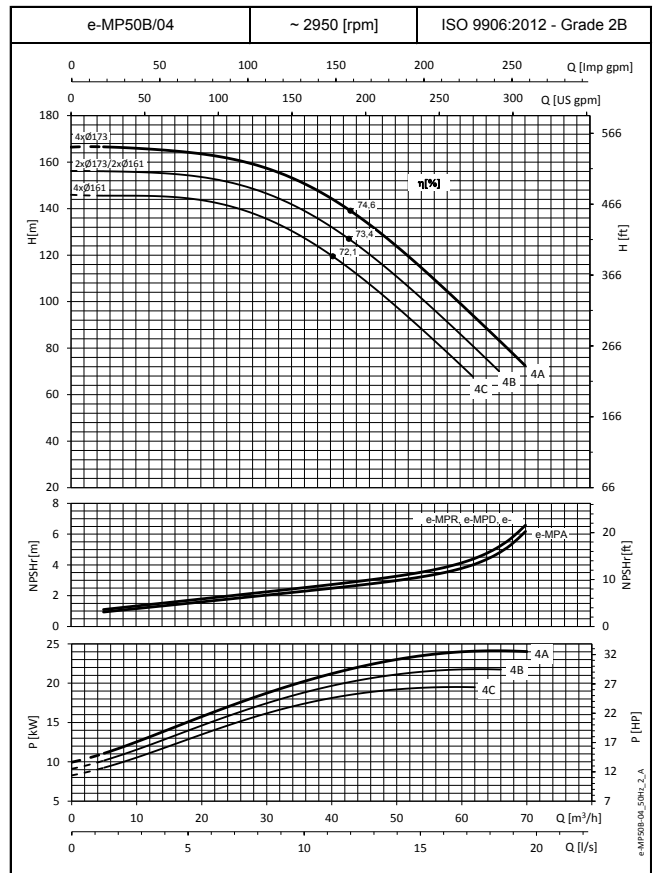
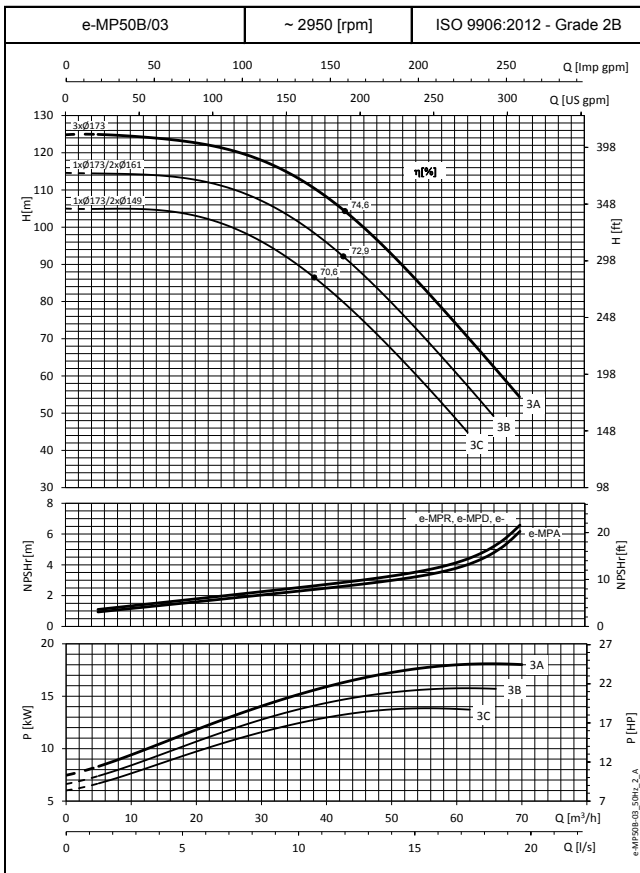
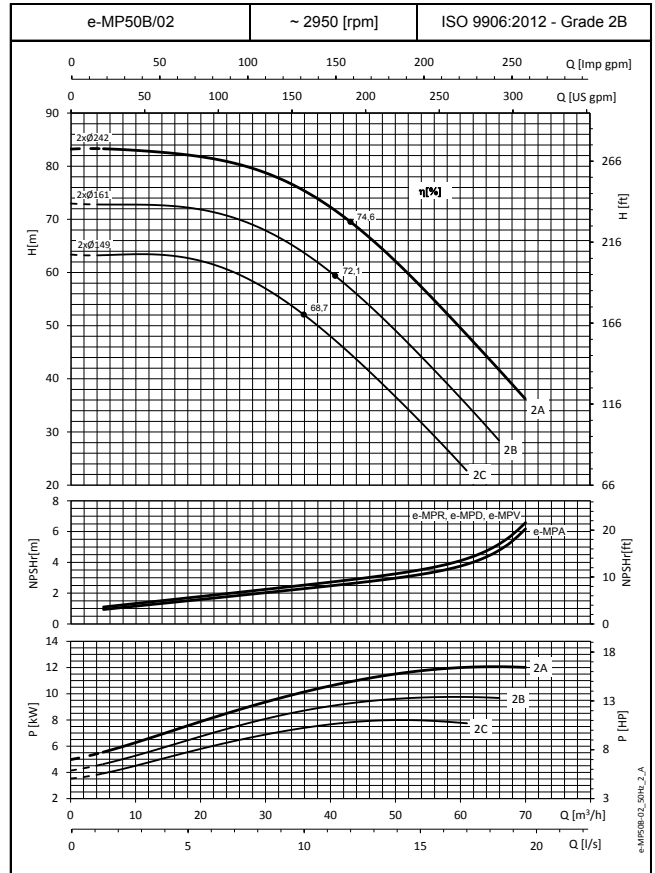
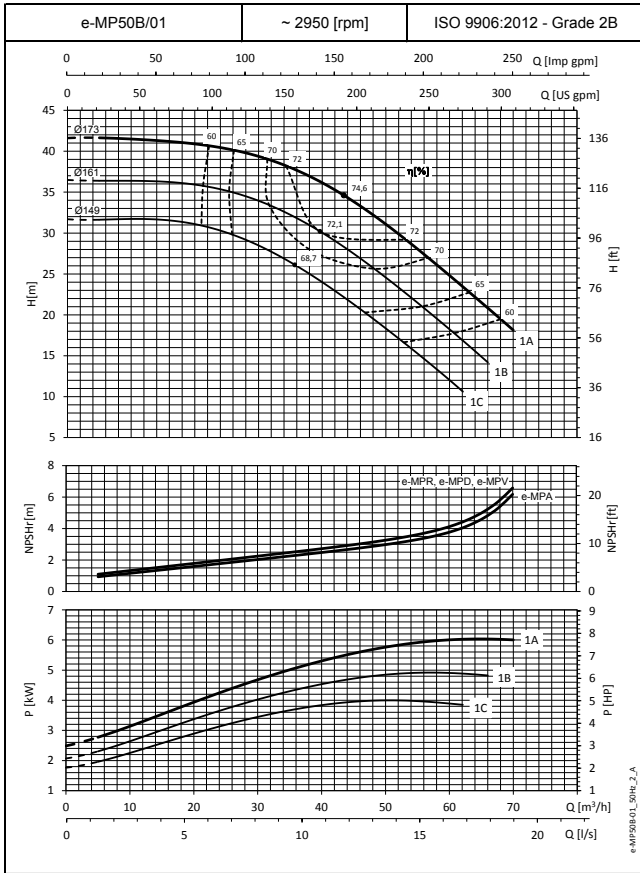

These performances are valid for cold water with density $\rho = 1 \text{ Kg/dm}^3$ and viscosity $\nu = 1 \text{ mm}^2/\text{sec}$.

e-MP50B SERIES

OPERATING CHARACTERISTICS AT 50 Hz, 2 POLES

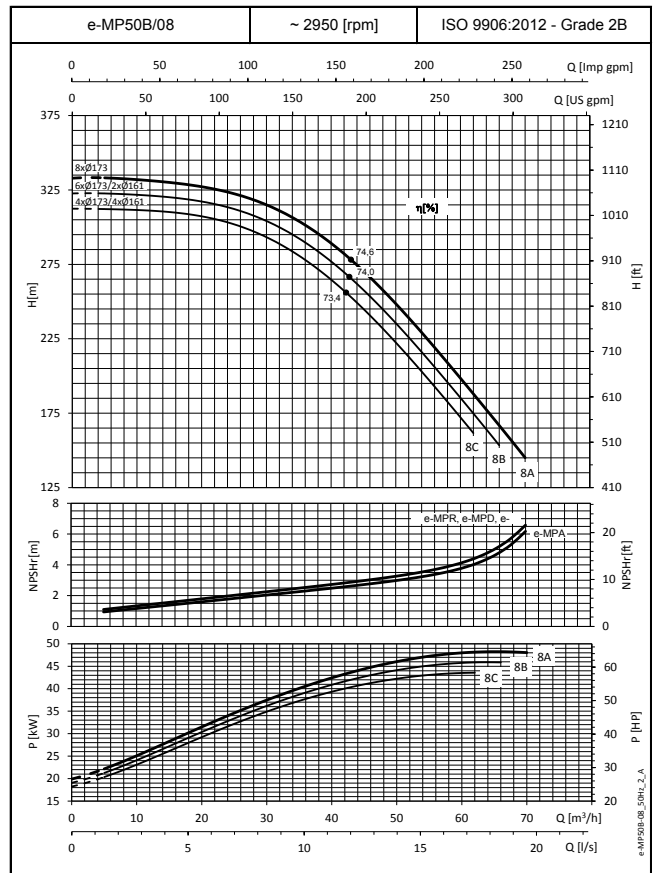
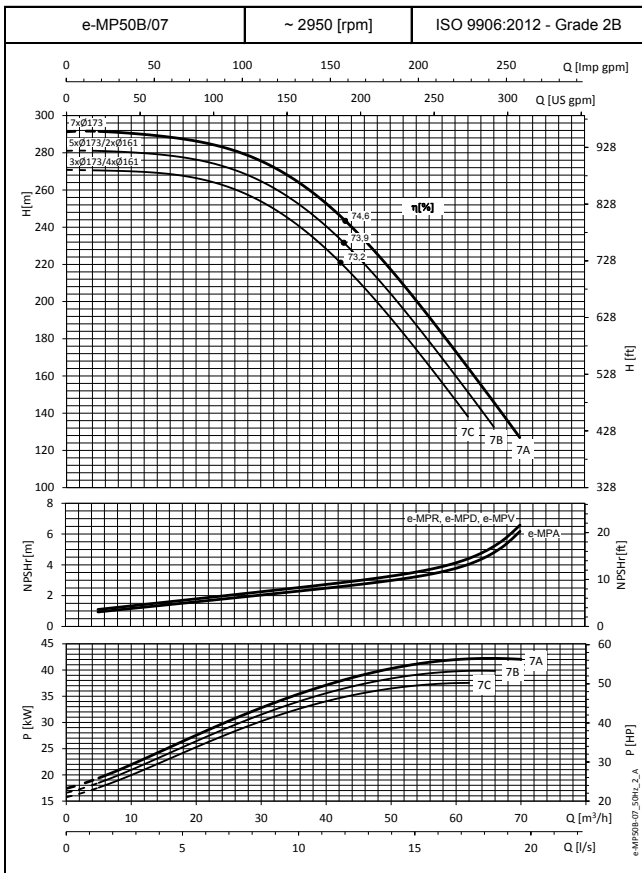
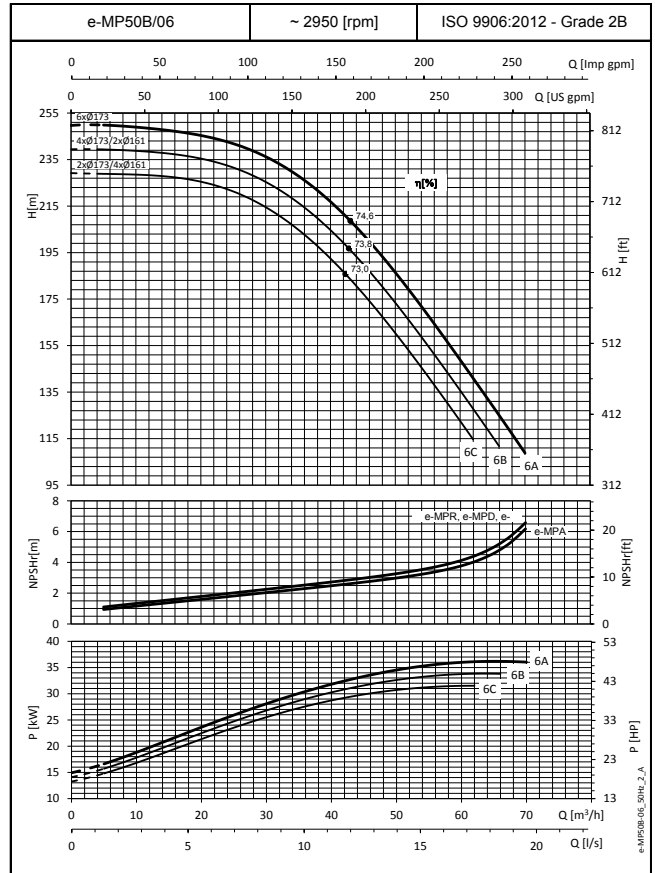
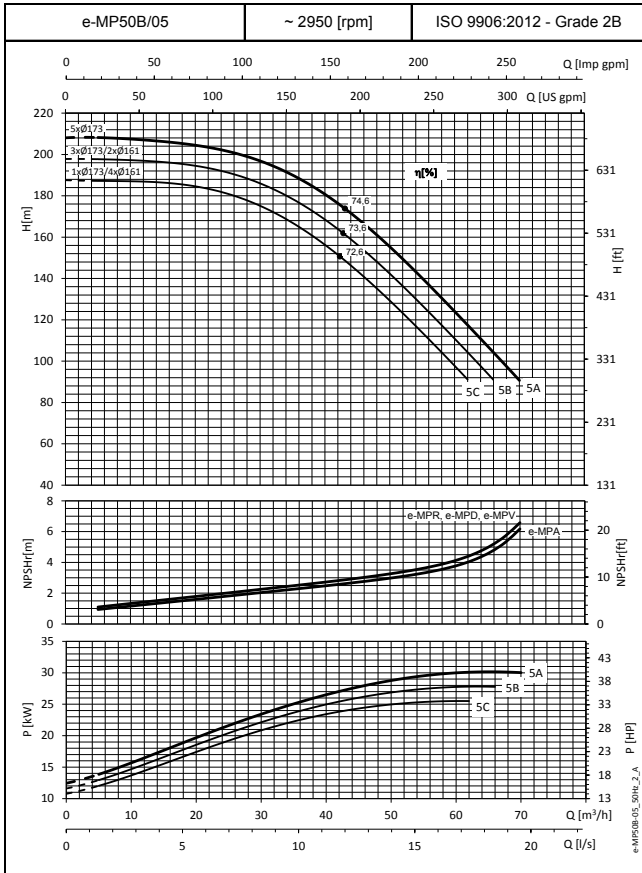

These performances are valid for cold water with density $\rho = 1 \text{ Kg/dm}^3$ and viscosity $\nu = 1 \text{ mm}^2/\text{sec}$.

e-MP50B SERIES OPERATING CHARACTERISTICS AT 50 Hz, 2 POLES

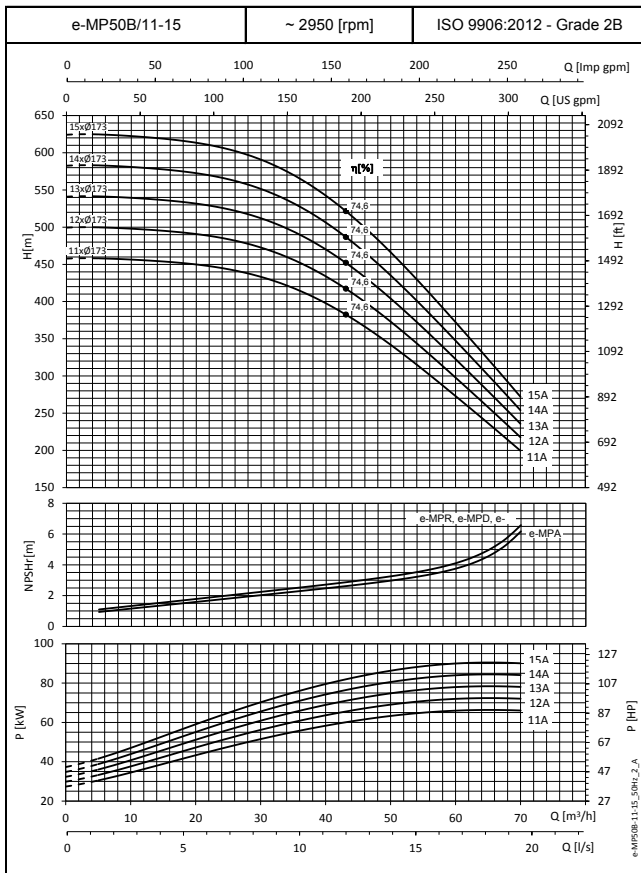
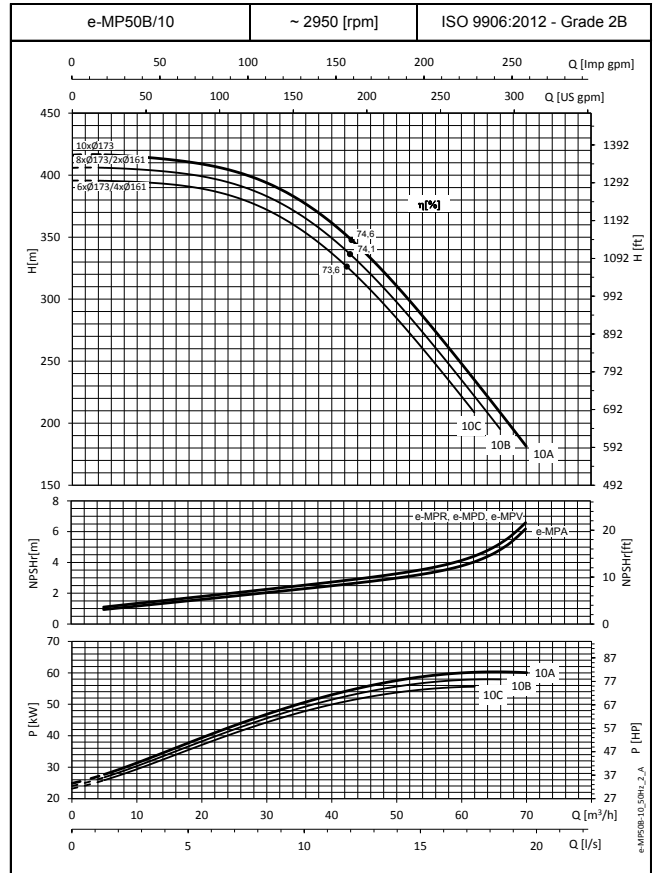
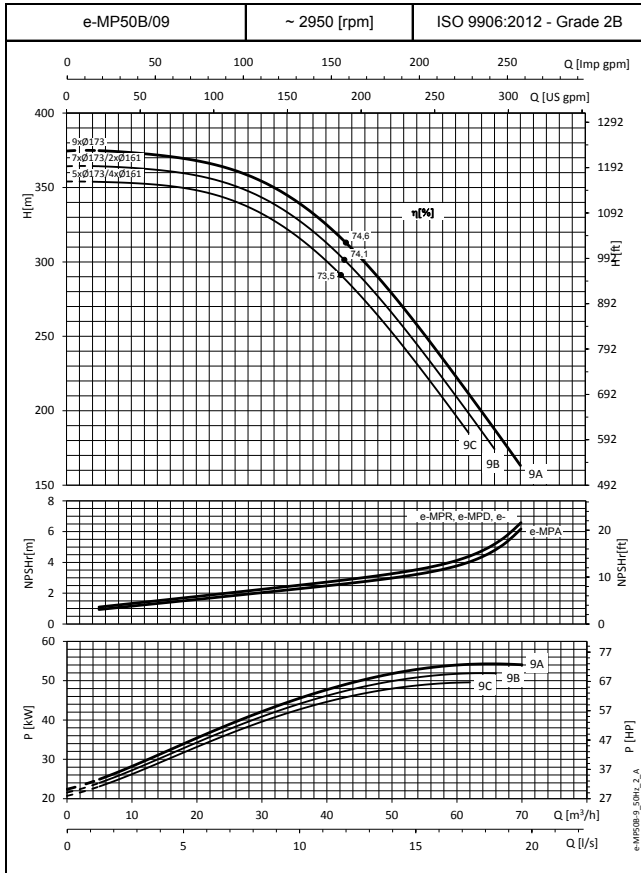

These performances are valid for cold water with density $\rho = 1 \text{ Kg/dm}^3$ and viscosity $\nu = 1 \text{ mm}^2/\text{sec}$.

e-MP65A SERIES

OPERATING CHARACTERISTICS AT 50 Hz, 2 POLES

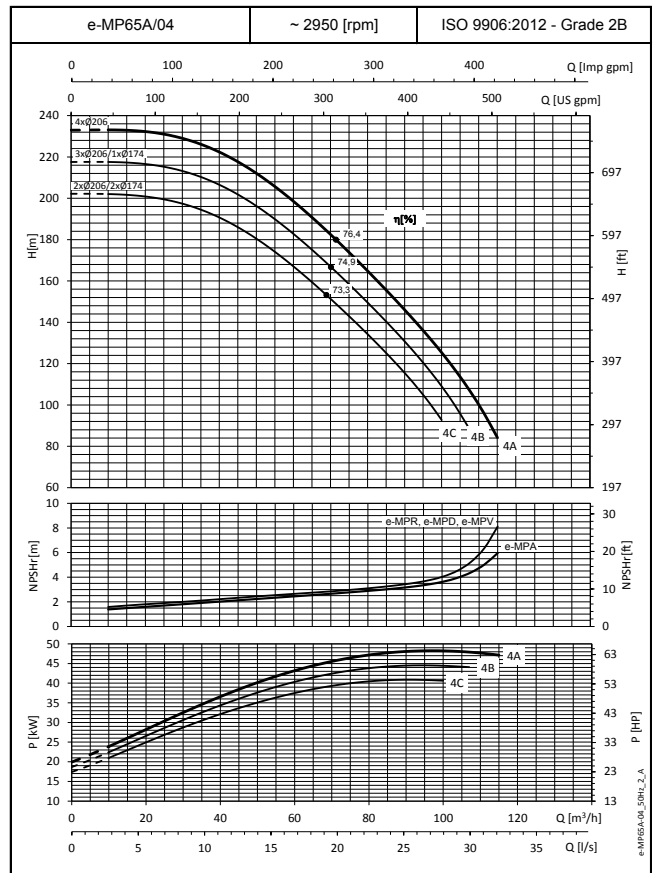
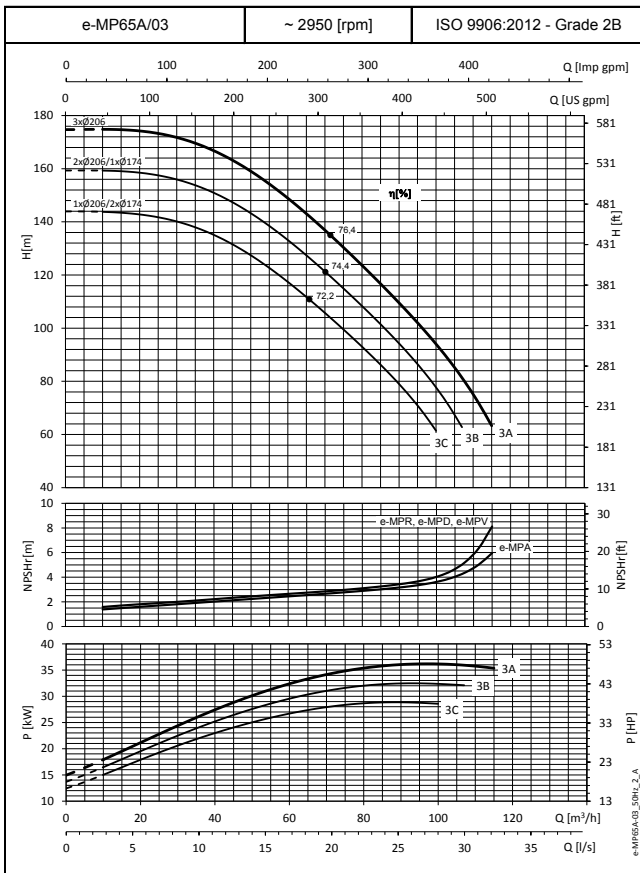
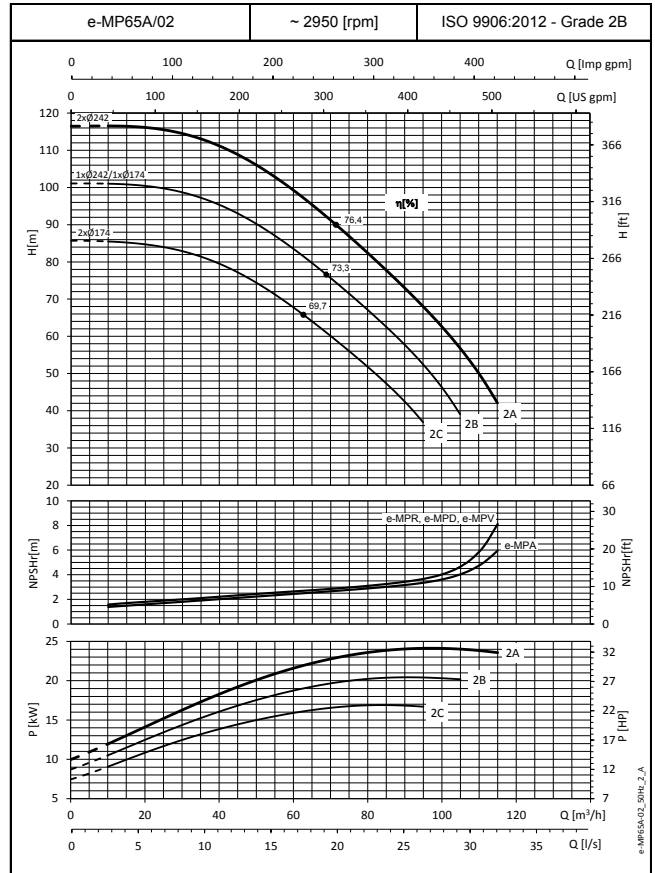
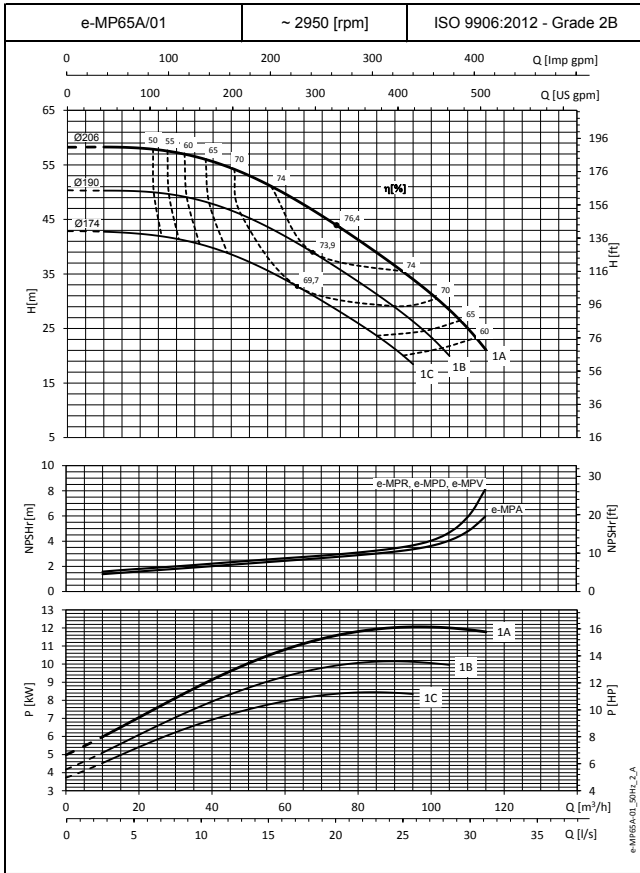

These performances are valid for cold water with density $\rho = 1 \text{ Kg/dm}^3$ and viscosity $\nu = 1 \text{ mm}^2/\text{sec}$.

e-MP65A SERIES OPERATING CHARACTERISTICS AT 50 Hz, 2 POLES

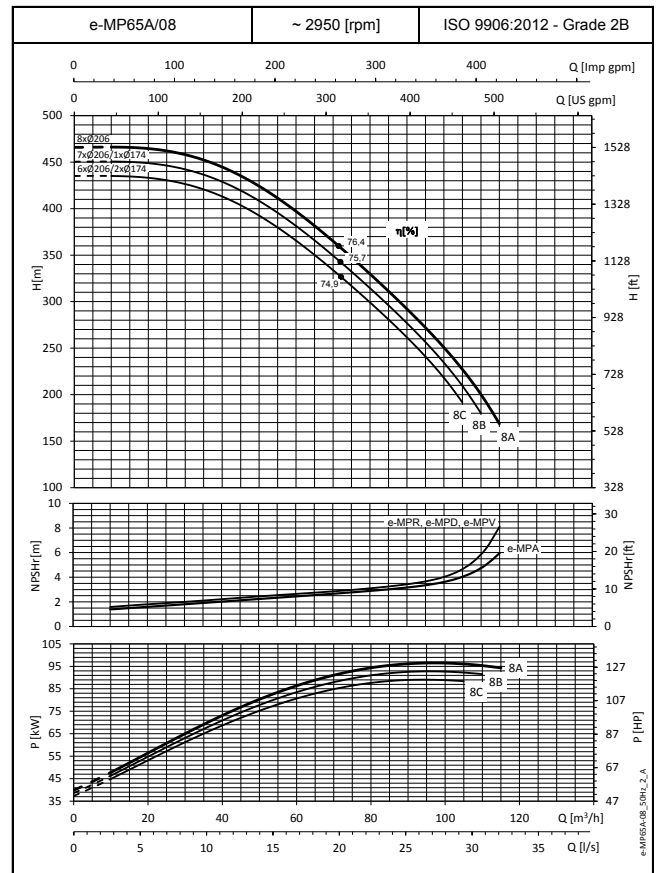
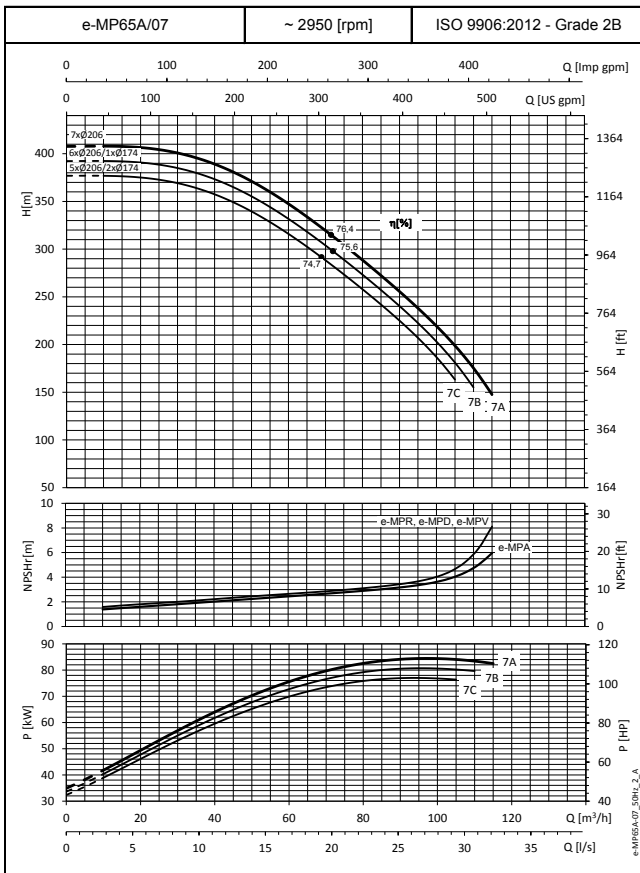
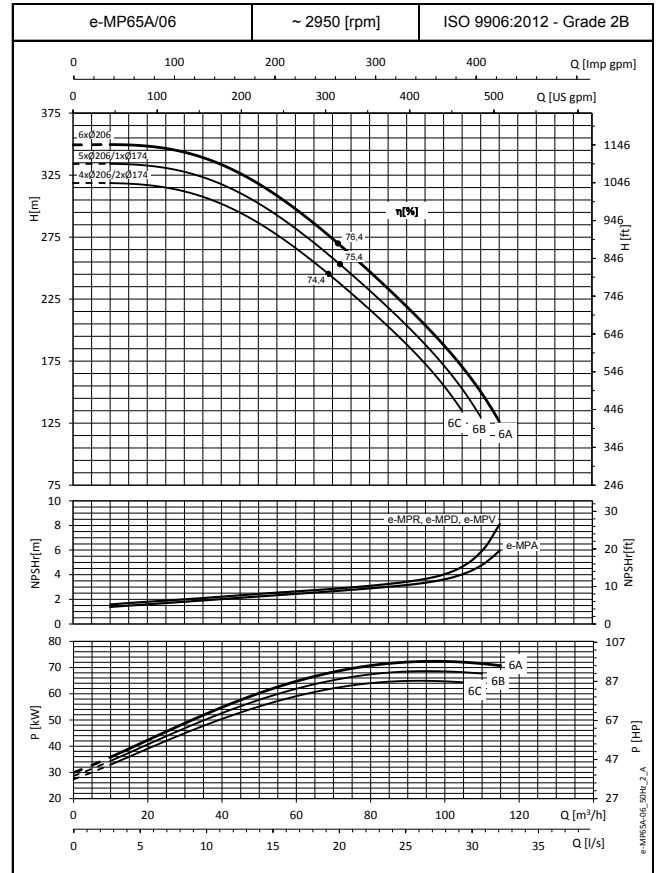
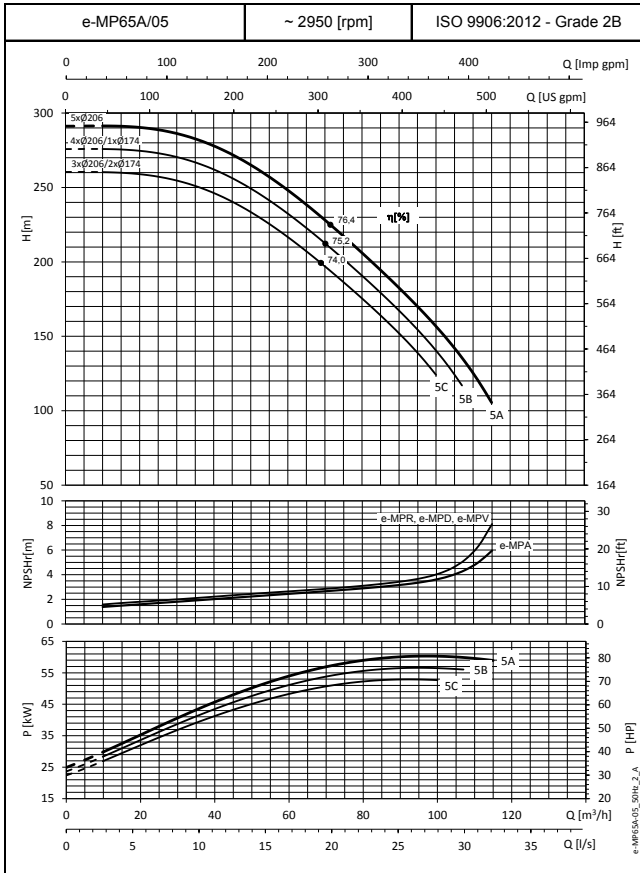

These performances are valid for cold water with density $\rho = 1 \text{ Kg/dm}^3$ and viscosity $\nu = 1 \text{ mm}^2/\text{sec}$.

e-MP65A SERIES OPERATING CHARACTERISTICS AT 50 Hz, 2 POLES

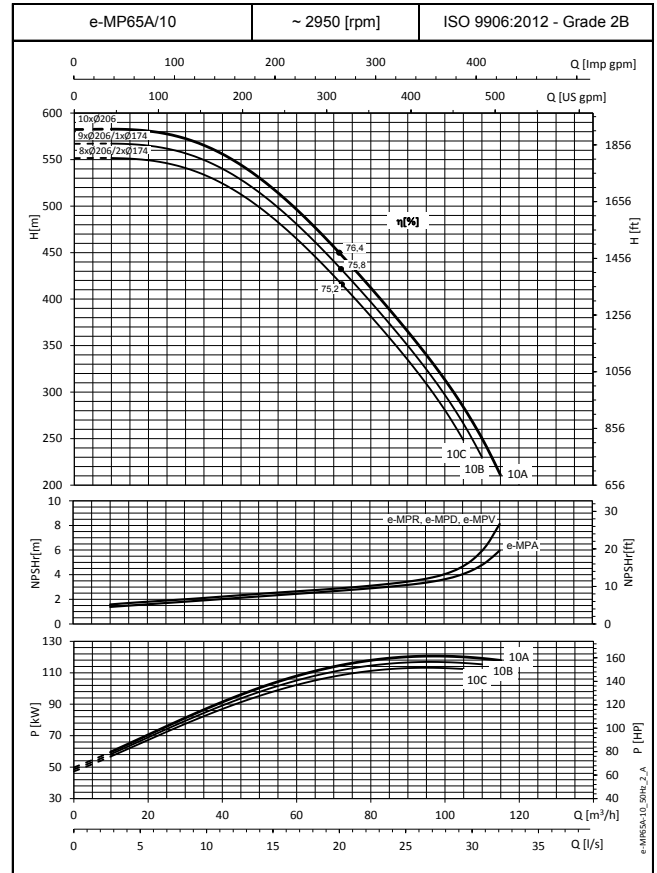
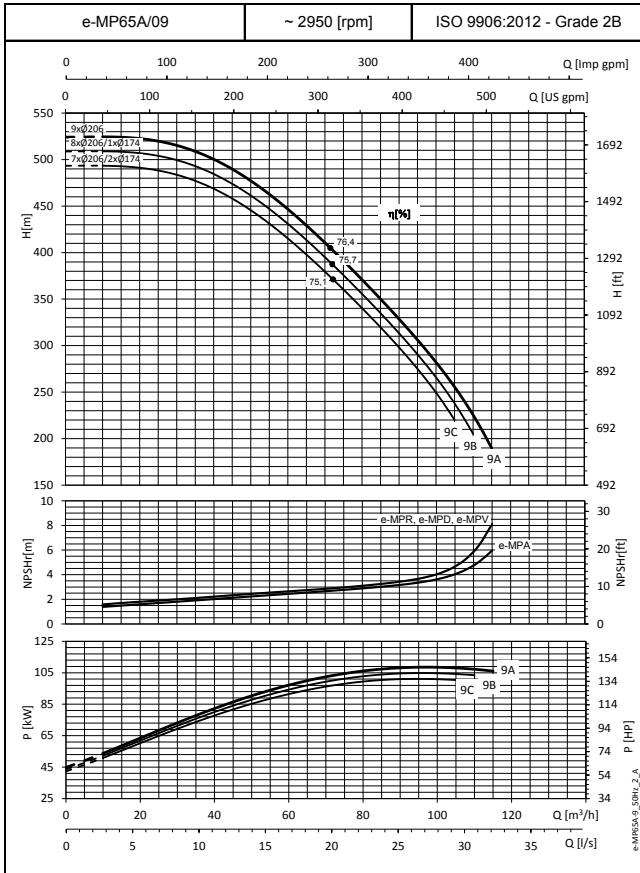

These performances are valid for cold water with density $\rho = 1 \text{ Kg/dm}^3$ and viscosity $\nu = 1 \text{ mm}^2/\text{sec}$.

e-MP65B SERIES

OPERATING CHARACTERISTICS AT 50 Hz, 2 POLES

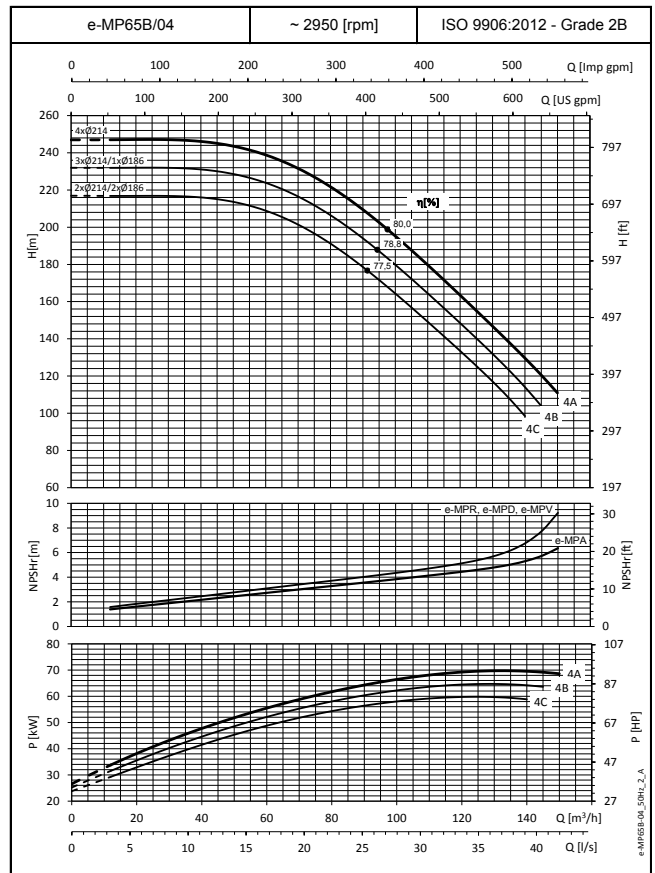
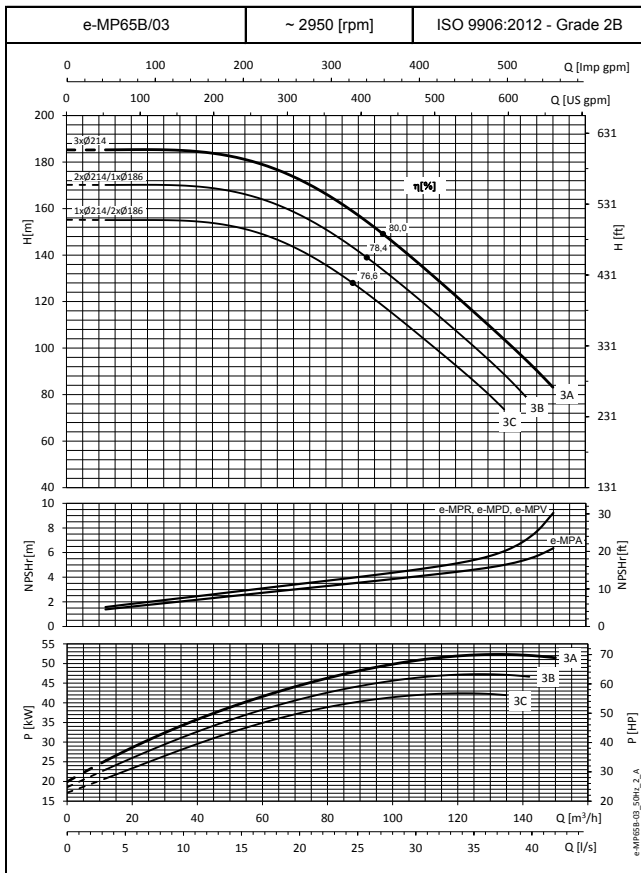
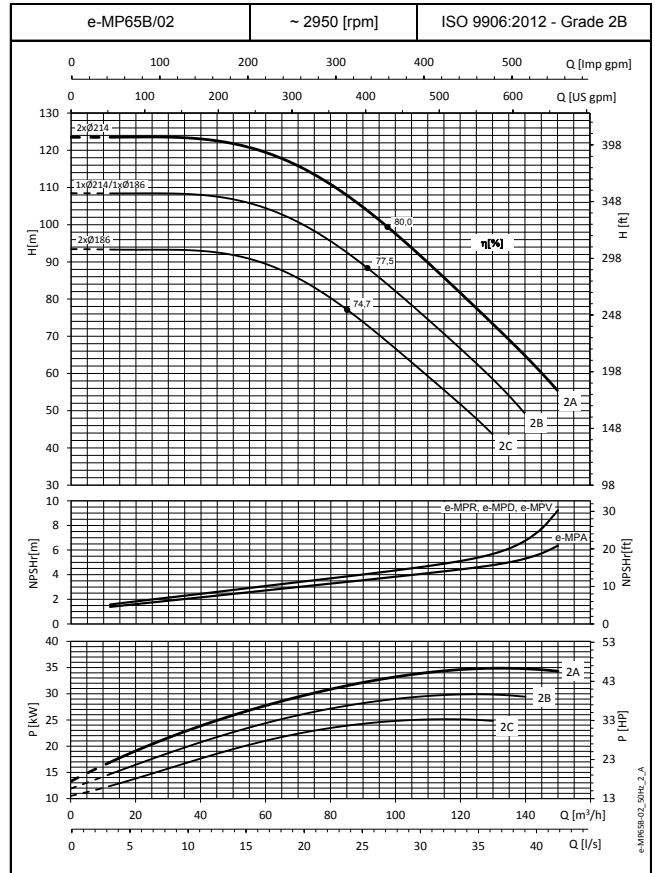
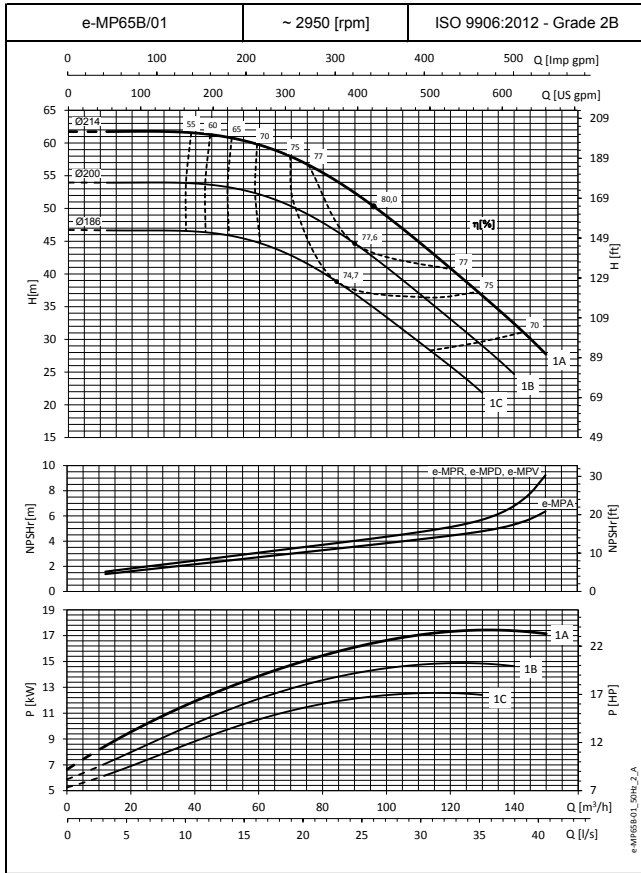

These performances are valid for cold water with density $\rho = 1 \text{ Kg/dm}^3$ and viscosity $\nu = 1 \text{ mm}^2/\text{sec}$.

e-MP65B SERIES OPERATING CHARACTERISTICS AT 50 Hz, 2 POLES

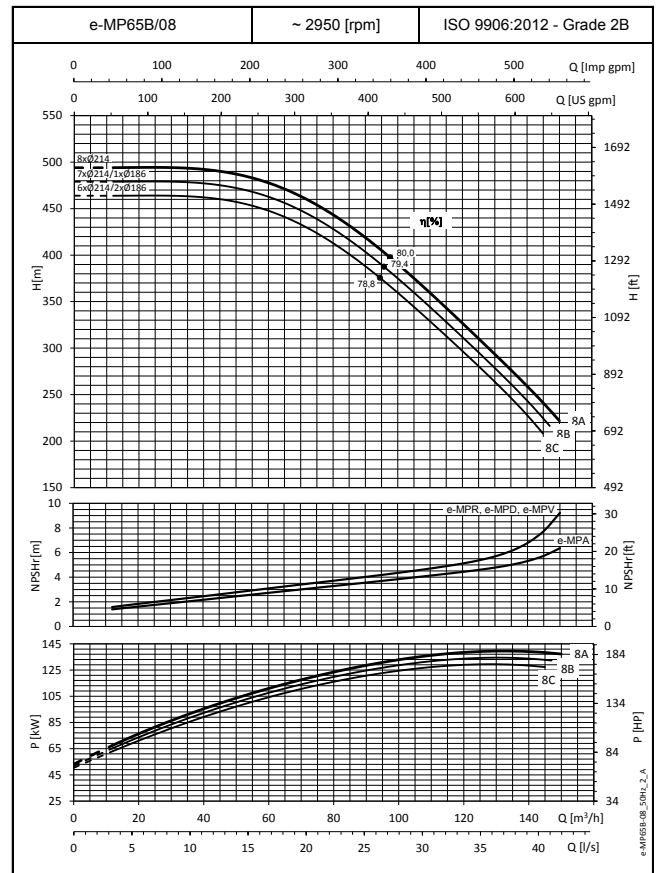
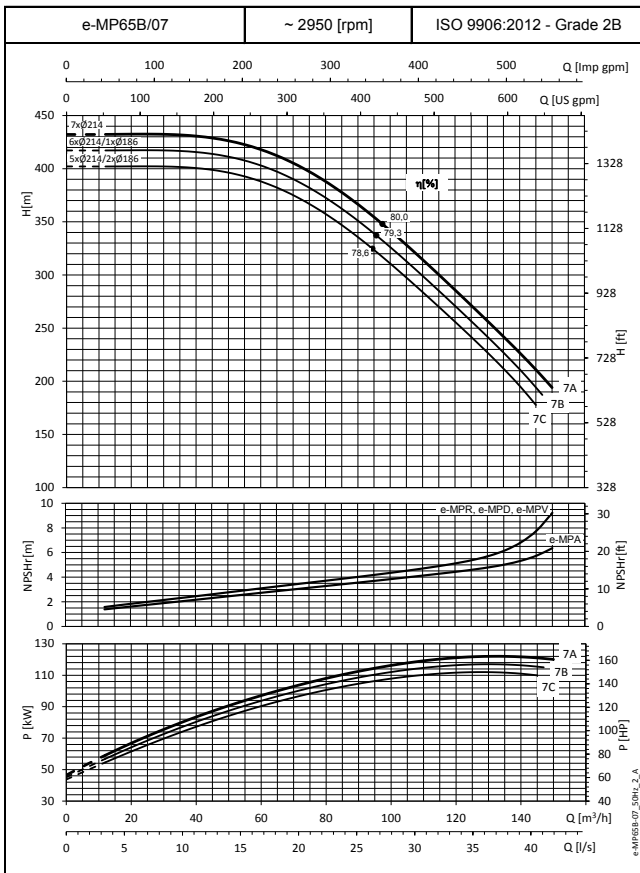
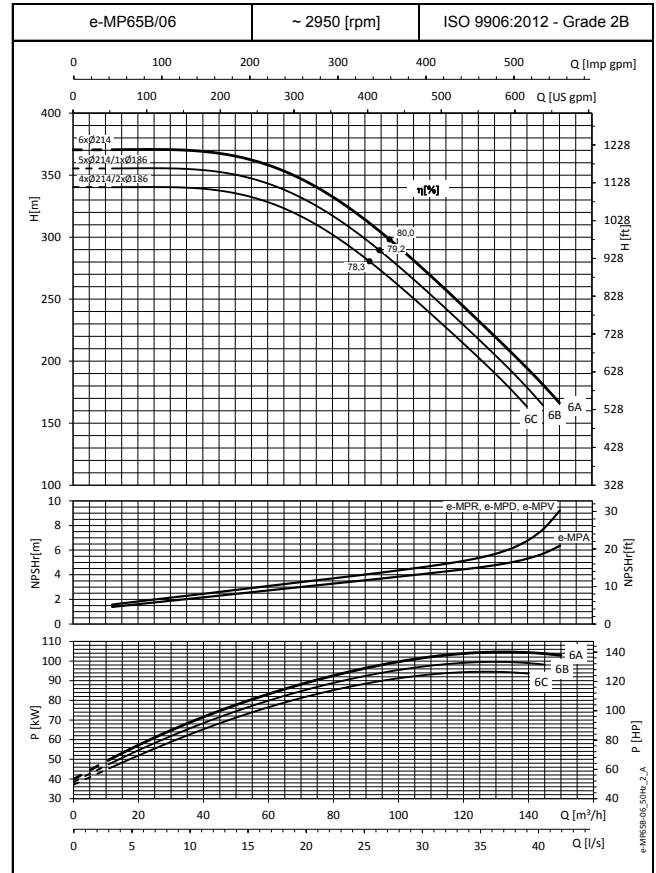
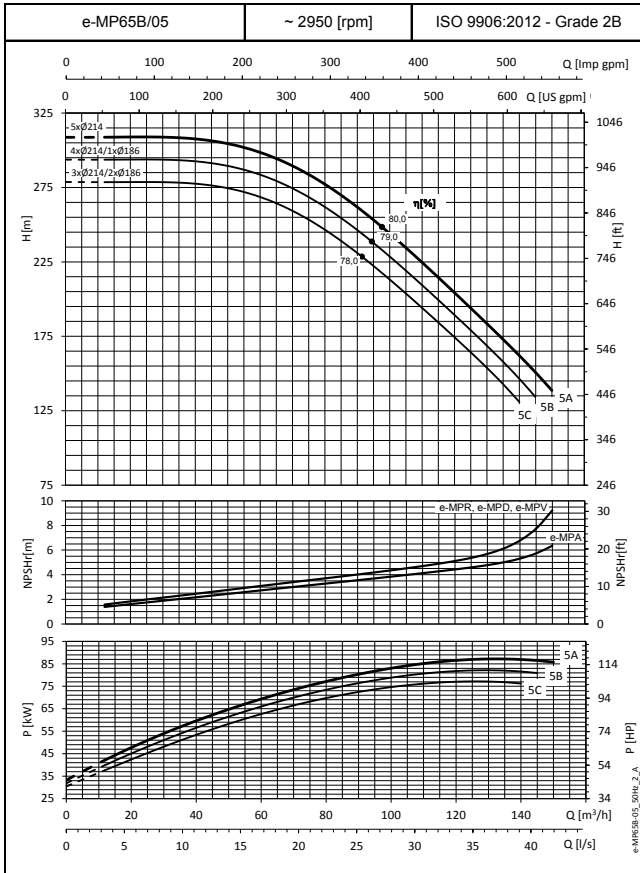

These performances are valid for cold water with density $\rho = 1 \text{ Kg/dm}^3$ and viscosity $\nu = 1 \text{ mm}^2/\text{sec}$.

e-MP65B SERIES OPERATING CHARACTERISTICS AT 50 Hz, 2 POLES

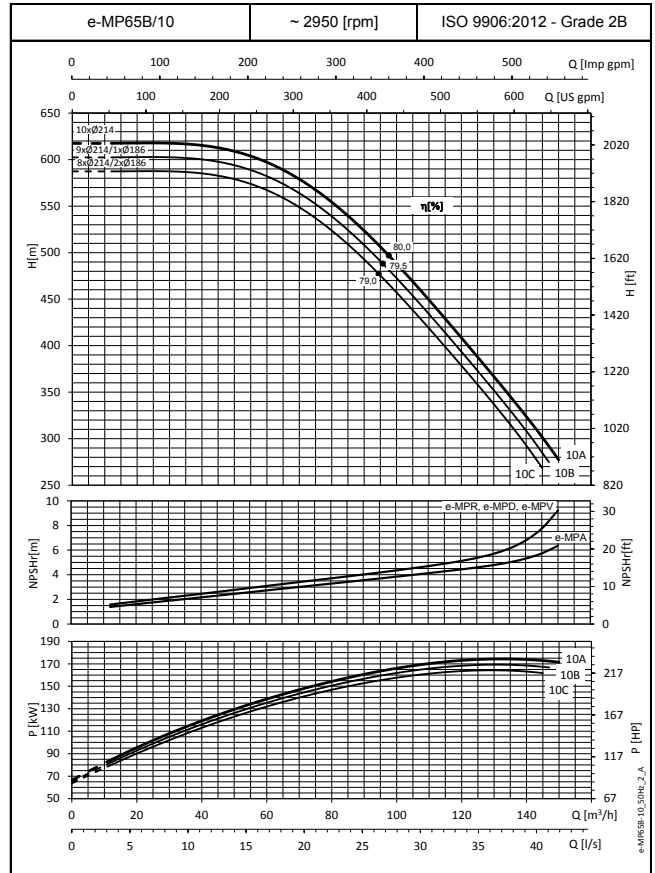
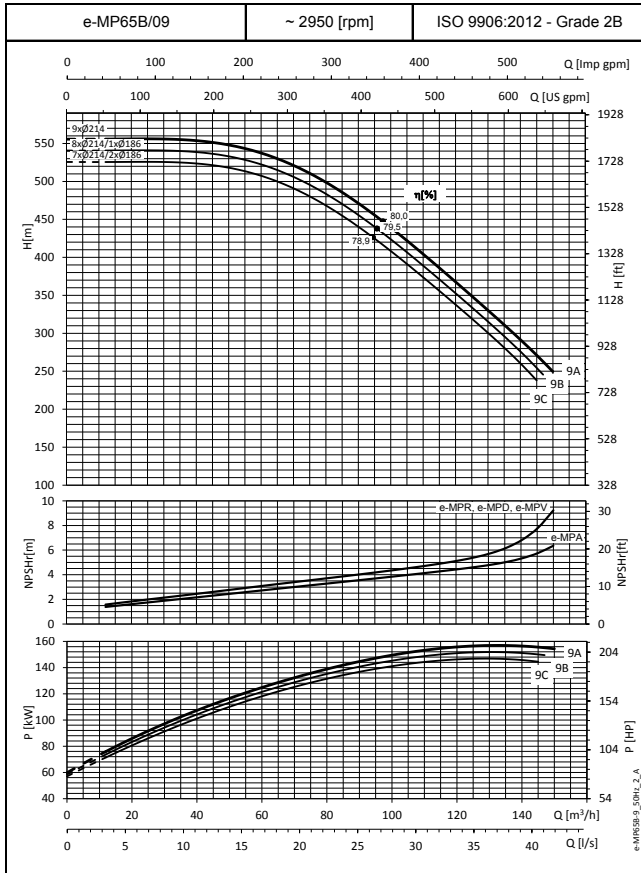

These performances are valid for cold water with density $\rho = 1 \text{ Kg/dm}^3$ and viscosity $\nu = 1 \text{ mm}^2/\text{sec}$.

e-MP100A SERIES

OPERATING CHARACTERISTICS AT 50 Hz, 2 POLES

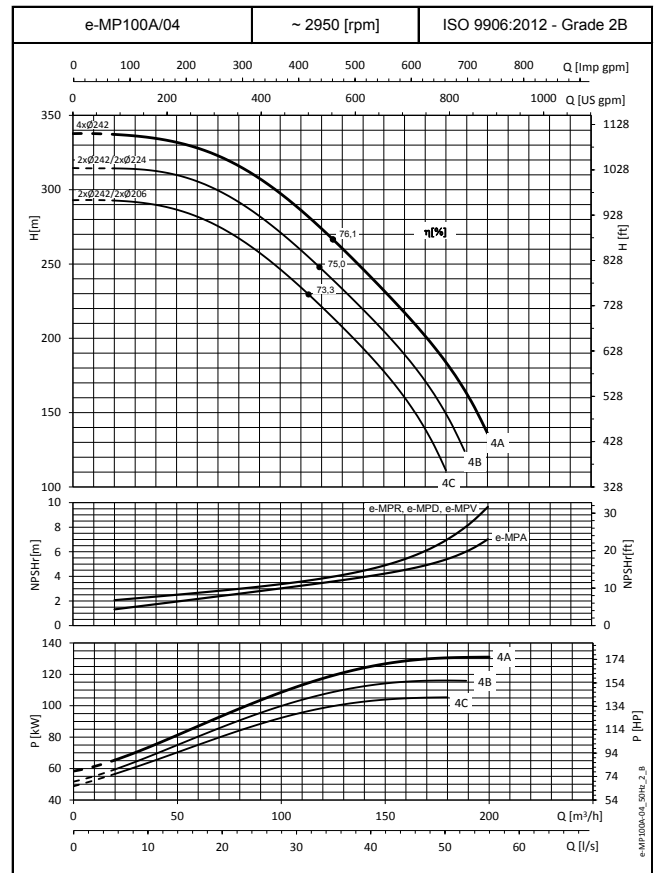
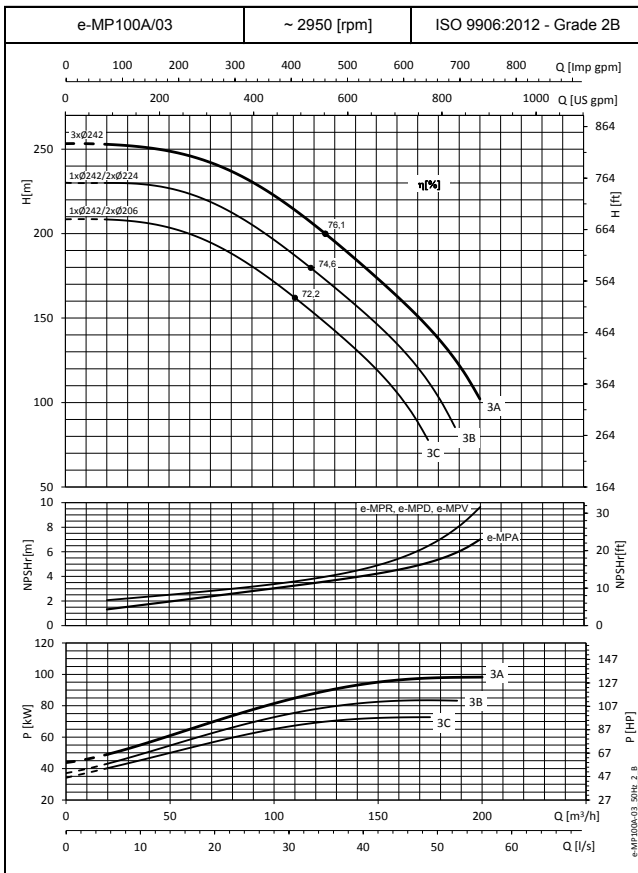
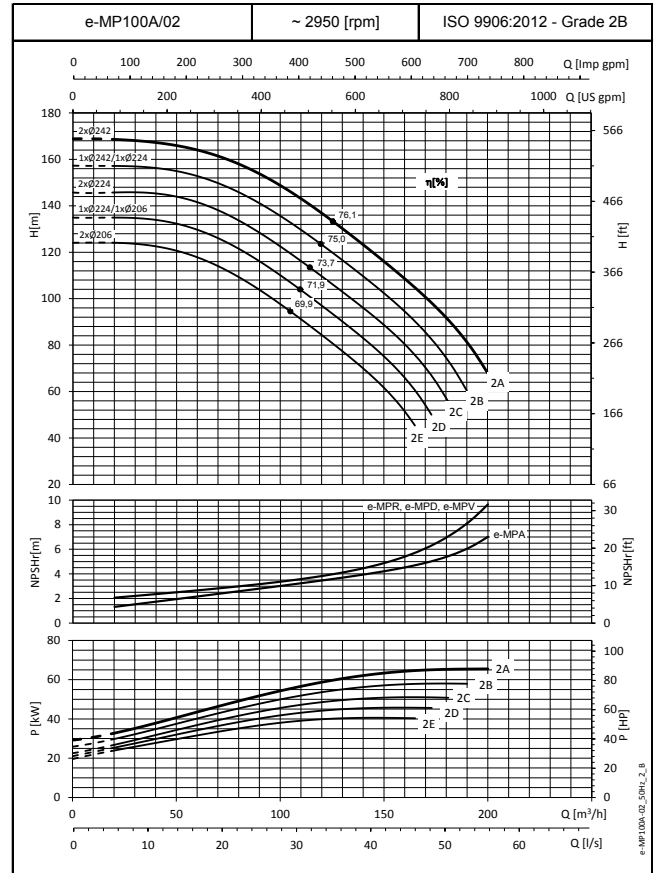
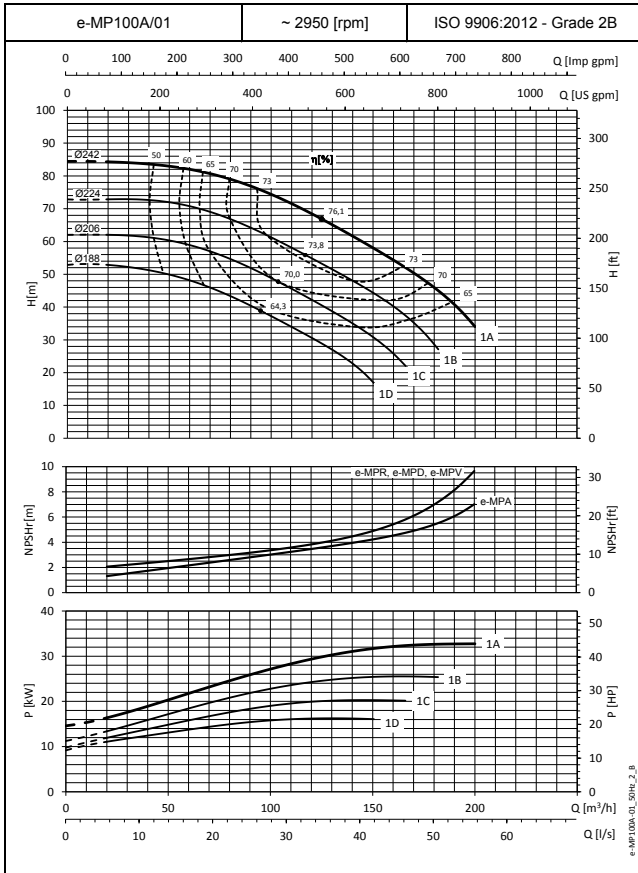

These performances are valid for cold water with density $\rho = 1 \text{ Kg/dm}^3$ and viscosity $\nu = 1 \text{ mm}^2/\text{sec}$.

e-MP100A SERIES OPERATING CHARACTERISTICS AT 50 Hz, 2 POLES

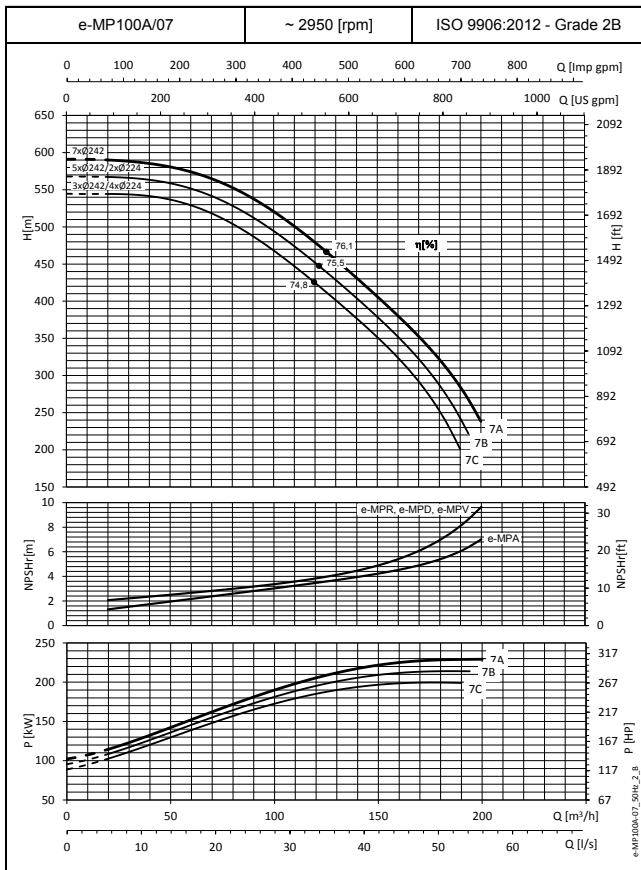
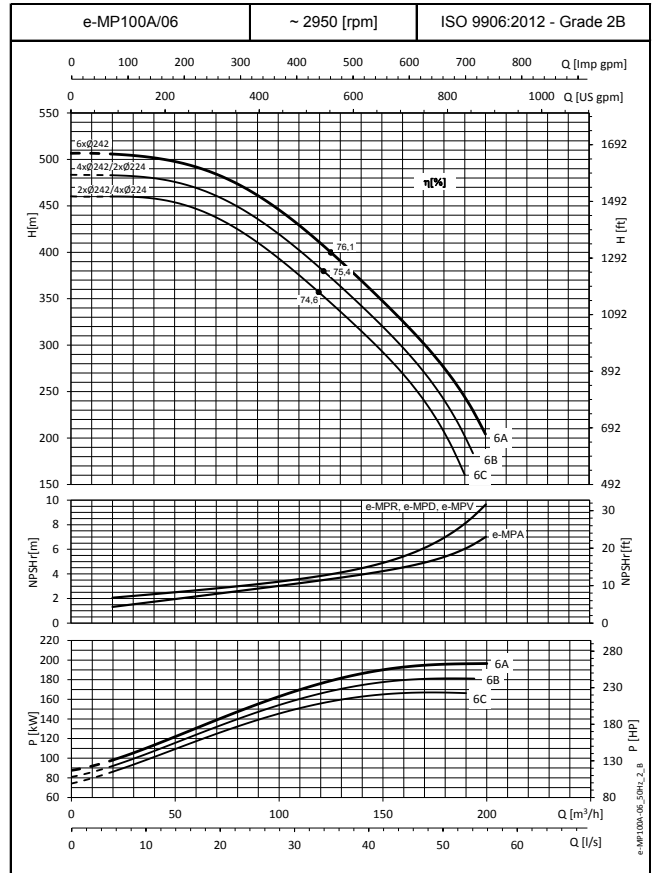
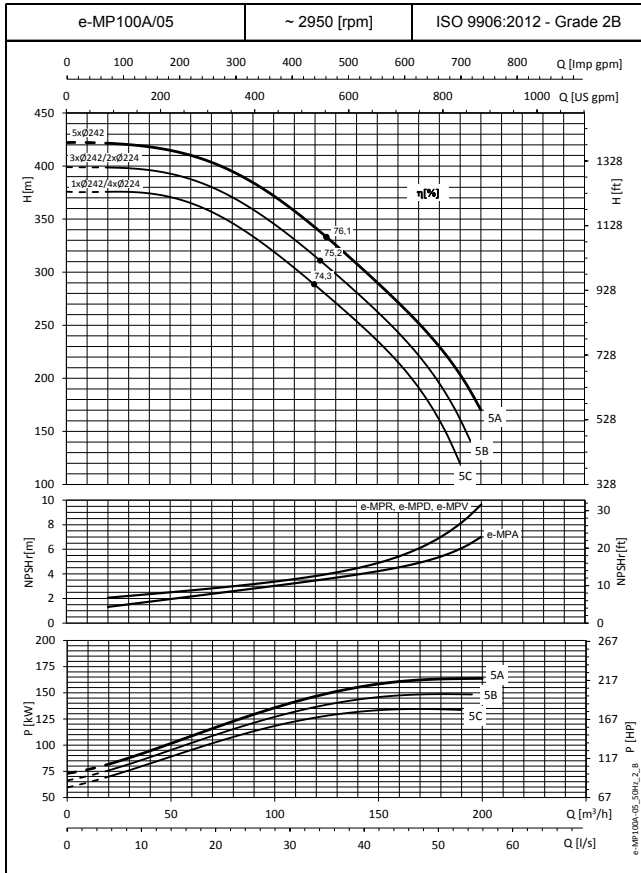

These performances are valid for cold water with density $\rho = 1 \text{ Kg/dm}^3$ and viscosity $\nu = 1 \text{ mm}^2/\text{sec}$.

e-MP100B SERIES OPERATING CHARACTERISTICS AT 50 Hz, 2 POLES

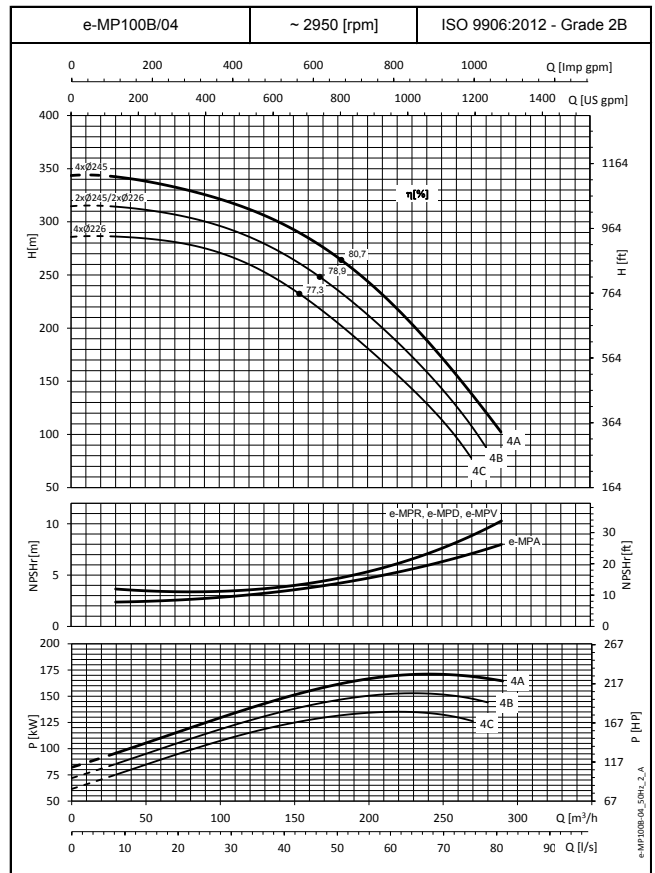
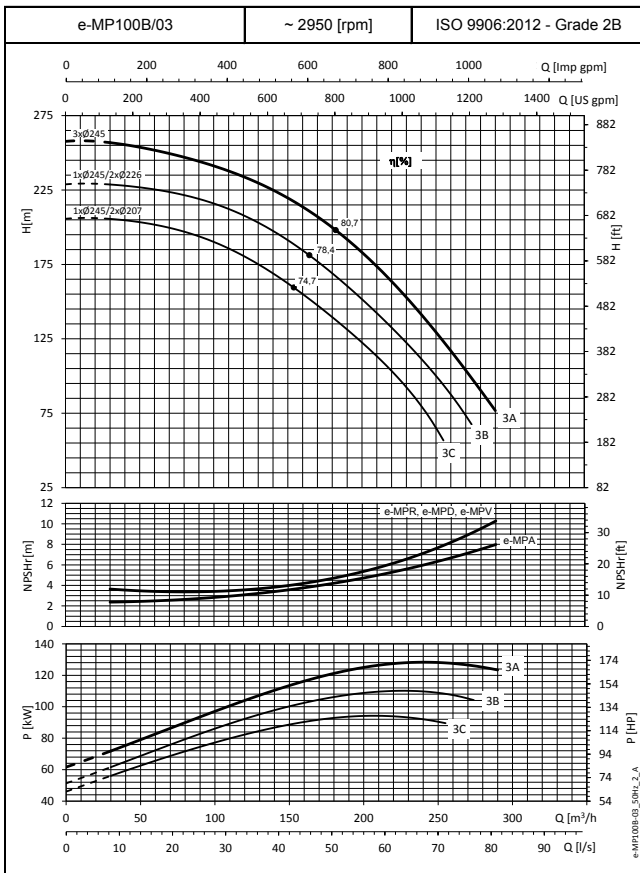
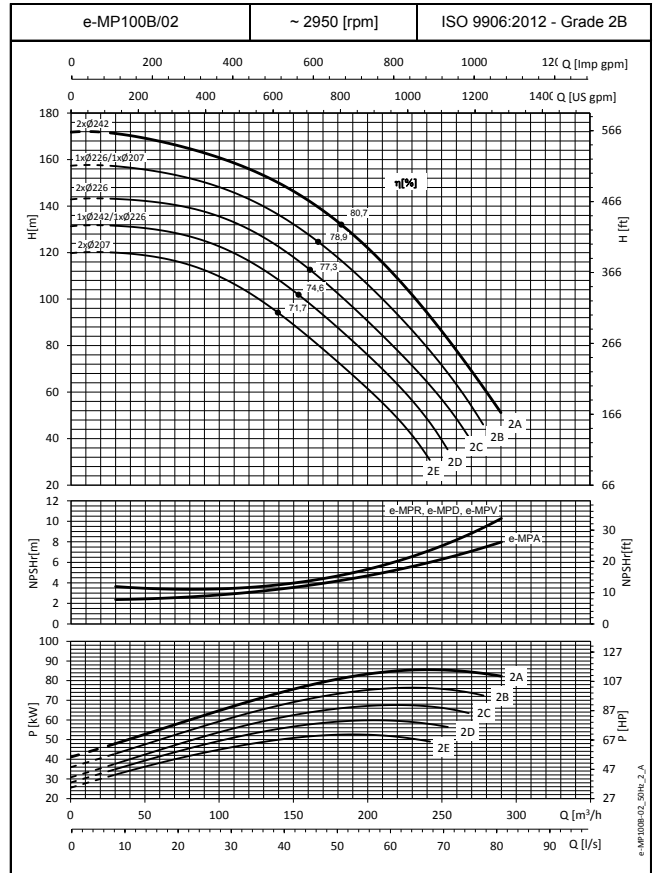
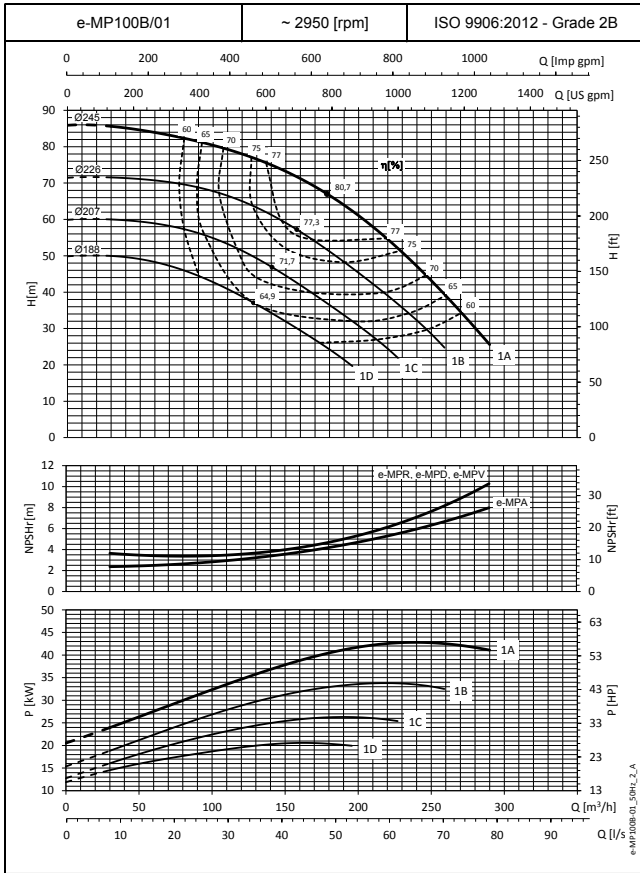

These performances are valid for cold water with density $\rho = 1 \text{ Kg/dm}^3$ and viscosity $\nu = 1 \text{ mm}^2/\text{sec}$.

e-MP100B SERIES OPERATING CHARACTERISTICS AT 50 Hz, 2 POLES

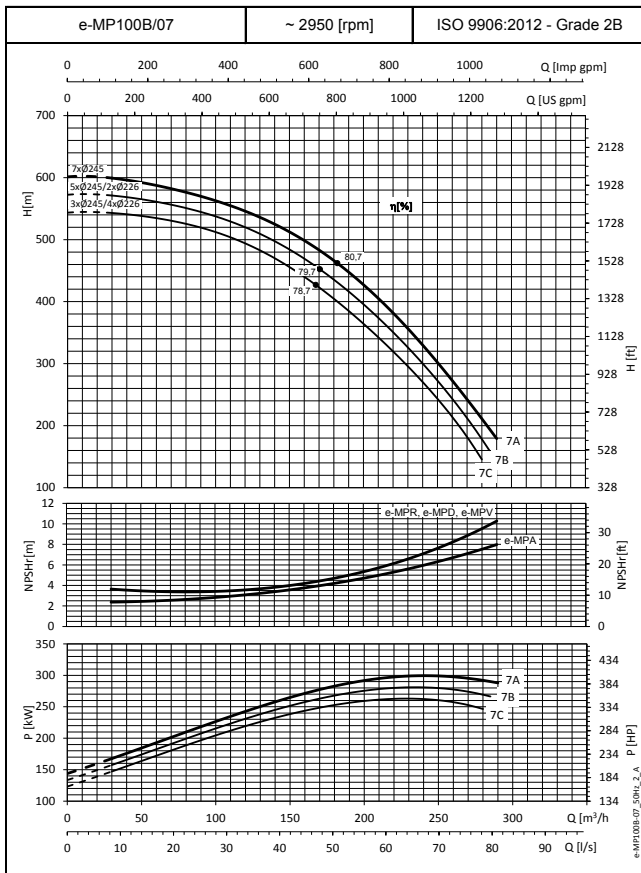
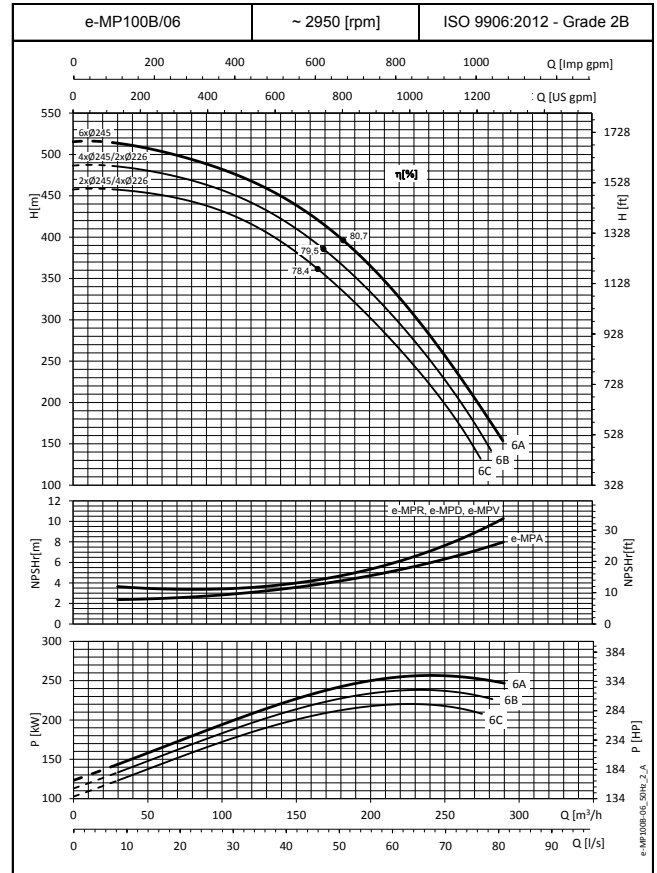
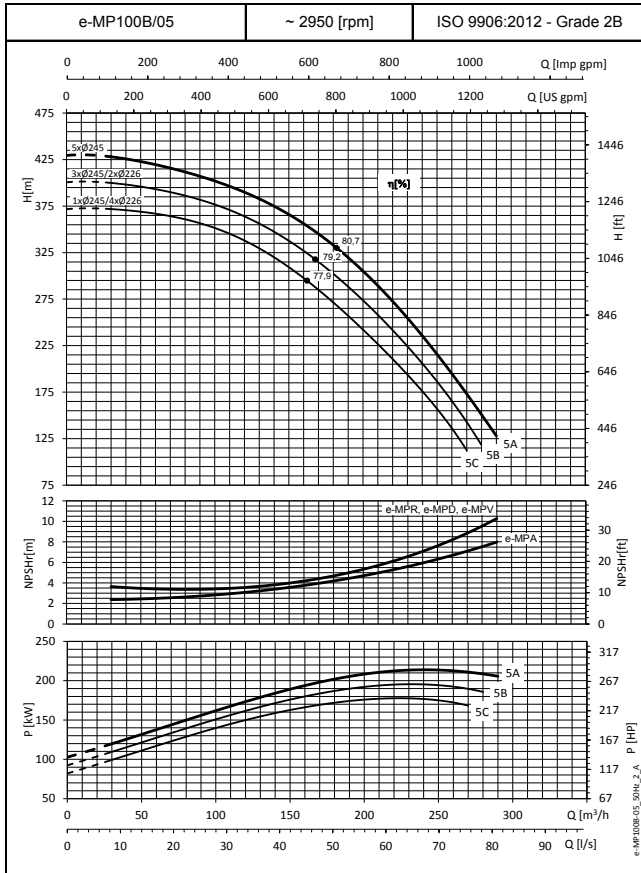

These performances are valid for cold water with density $\rho = 1 \text{ Kg/dm}^3$ and viscosity $\nu = 1 \text{ mm}^2/\text{sec}$.

e-MP125A SERIES

OPERATING CHARACTERISTICS AT 50 Hz, 2 POLES

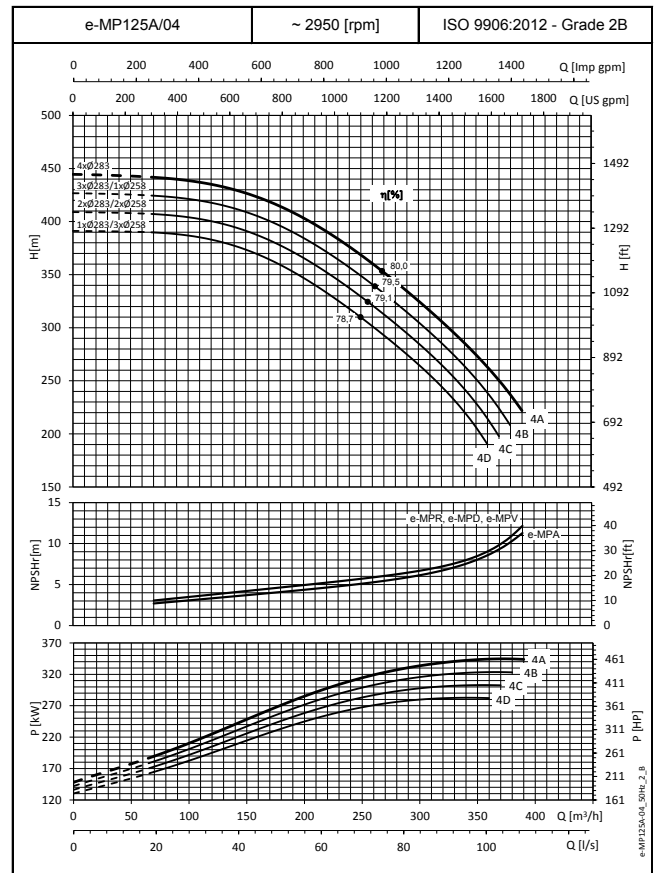
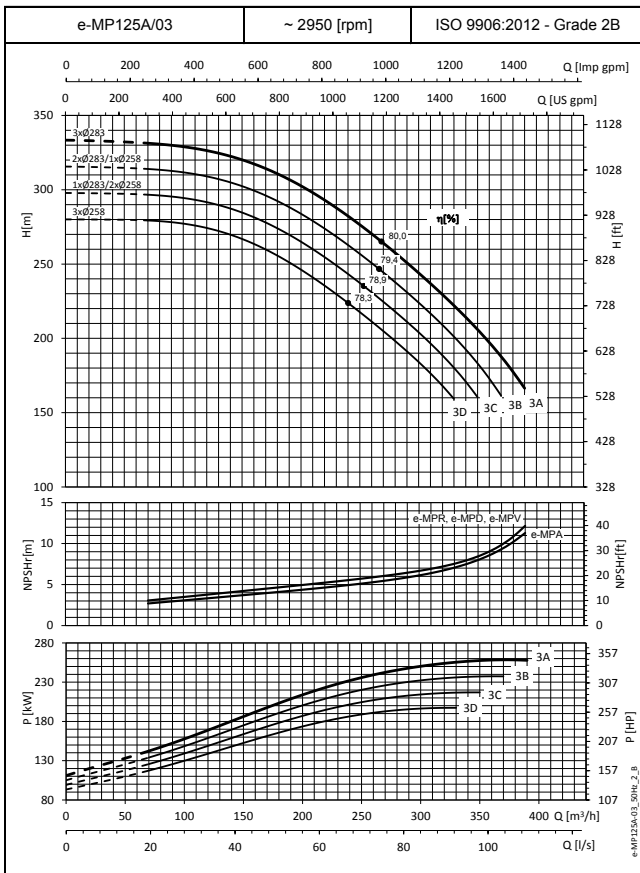
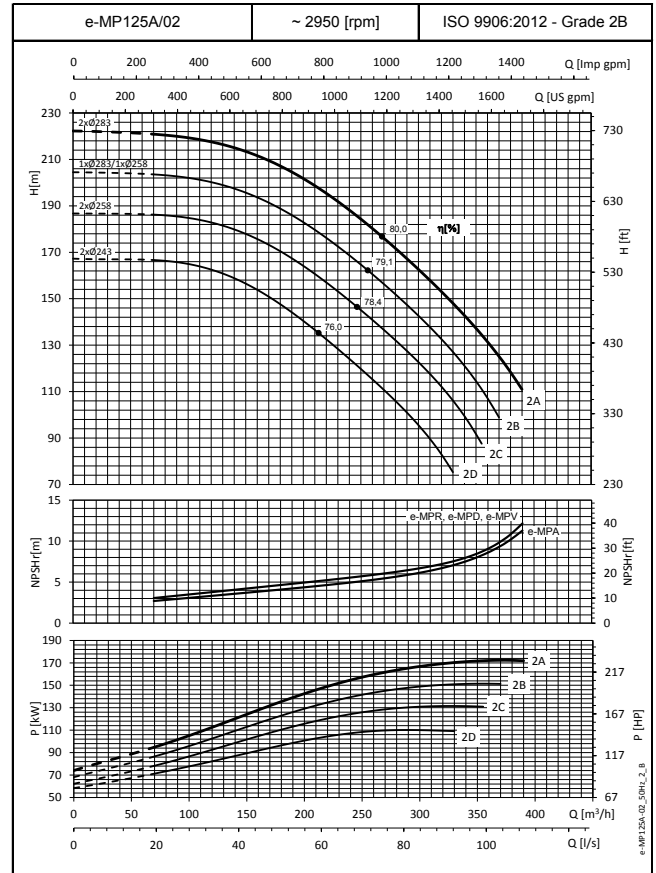
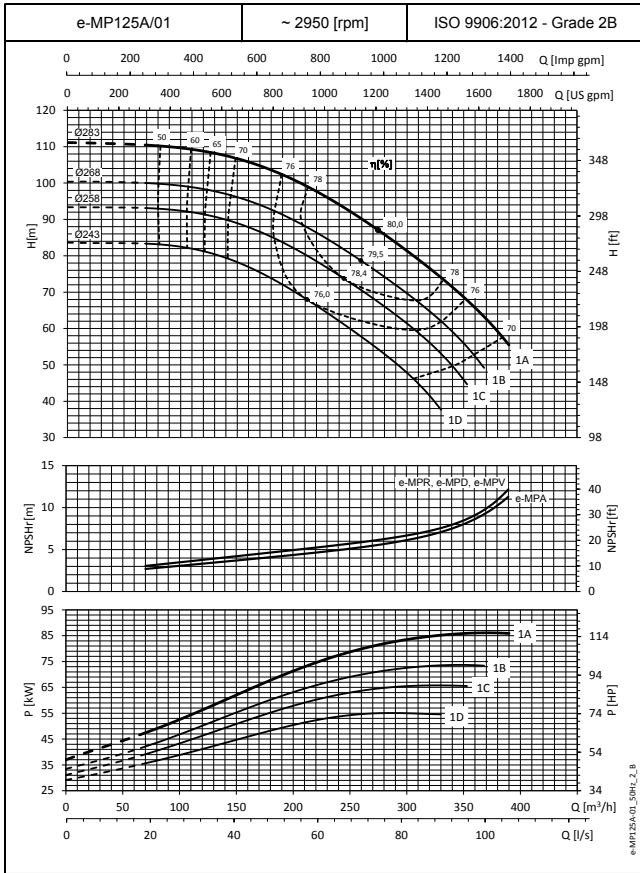

These performances are valid for cold water with density $\rho = 1 \text{ Kg/dm}^3$ and viscosity $\nu = 1 \text{ mm}^2/\text{sec}$.

e-MP125A SERIES OPERATING CHARACTERISTICS AT 50 Hz, 2 POLES

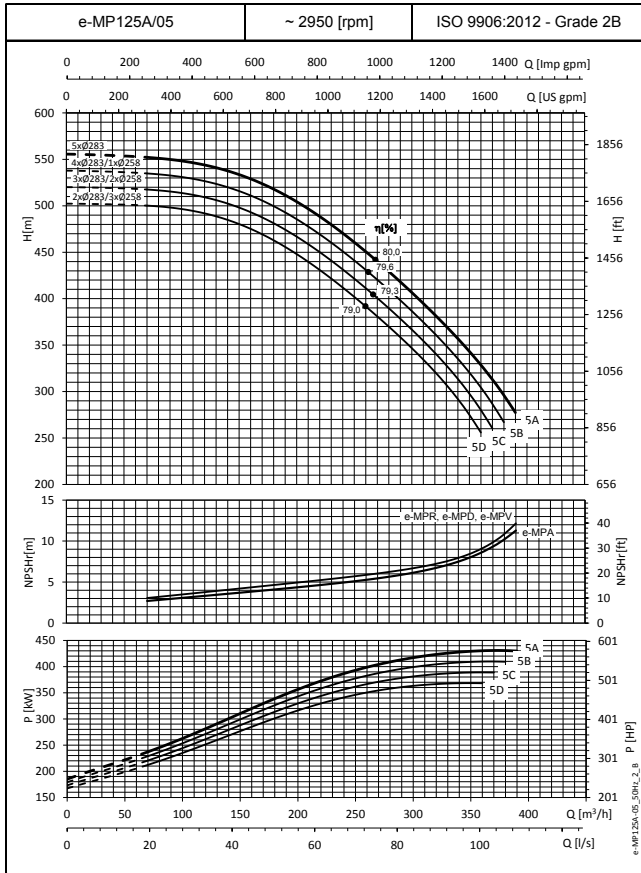

These performances are valid for cold water with density $\rho = 1 \text{ Kg/dm}^3$ and viscosity $\nu = 1 \text{ mm}^2/\text{sec}$.

e-MP125B SERIES

OPERATING CHARACTERISTICS AT 50 Hz, 2 POLES

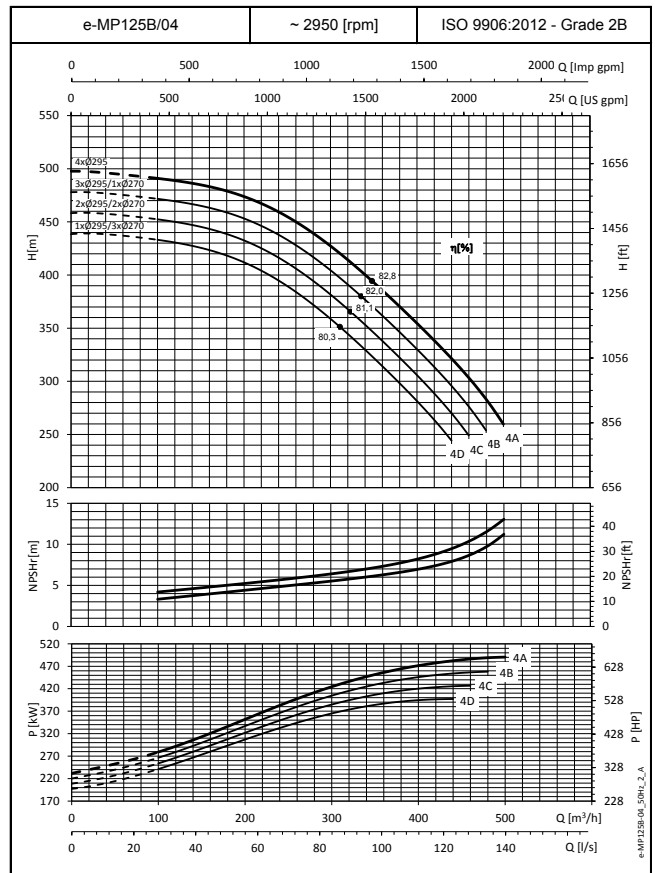
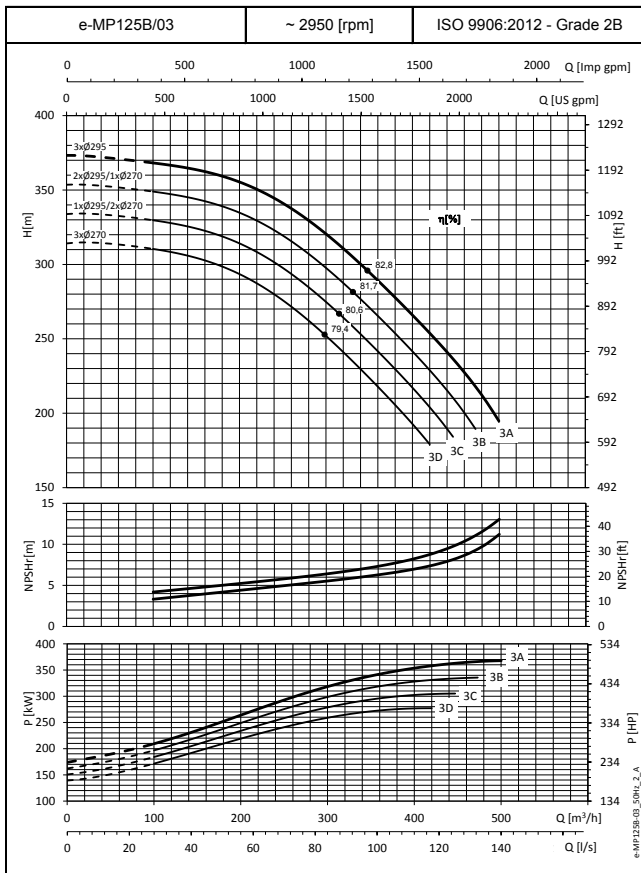
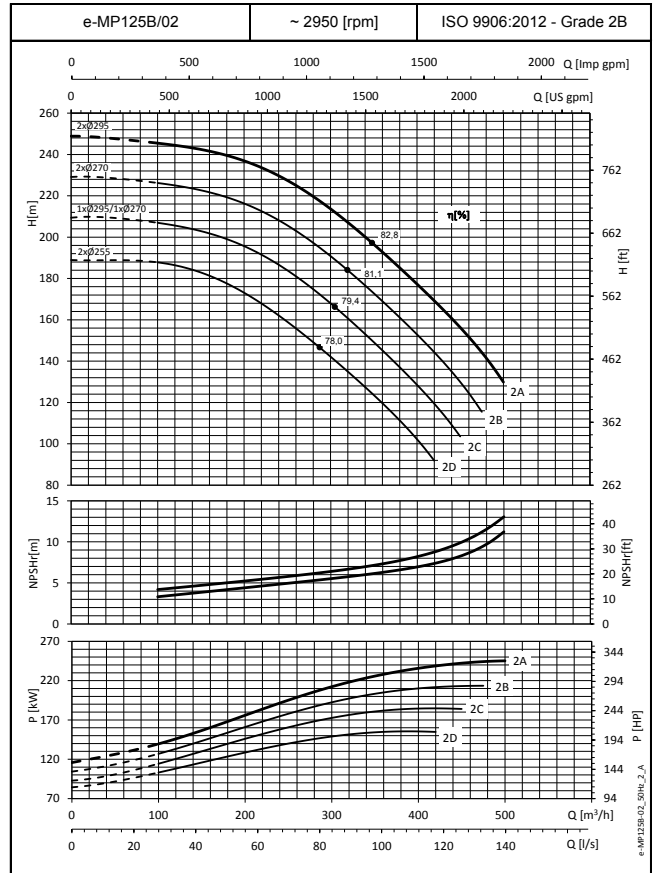
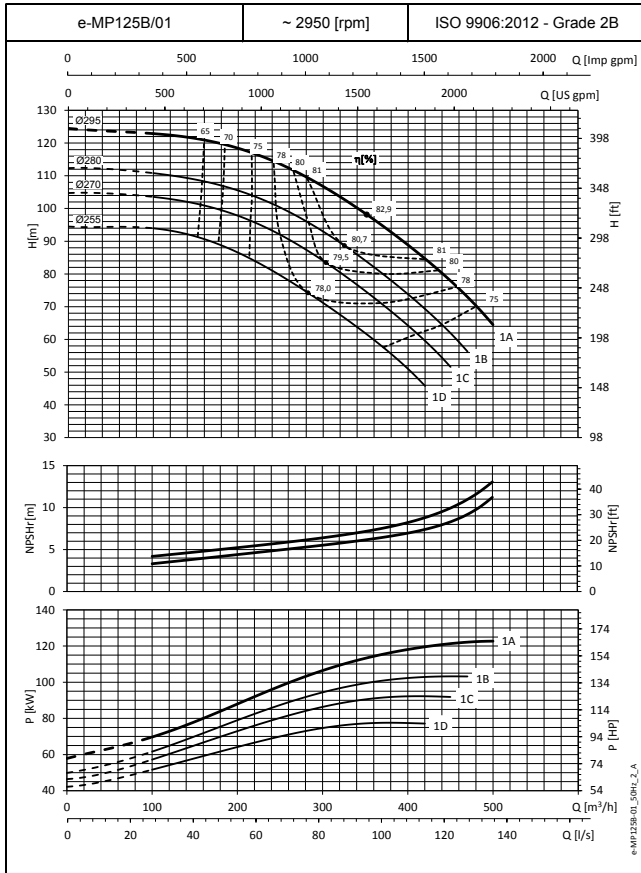

These performances are valid for cold water with density $\rho = 1 \text{ Kg/dm}^3$ and viscosity $\nu = 1 \text{ mm}^2/\text{sec}$.

e-MP125B SERIES OPERATING CHARACTERISTICS AT 50 Hz, 2 POLES

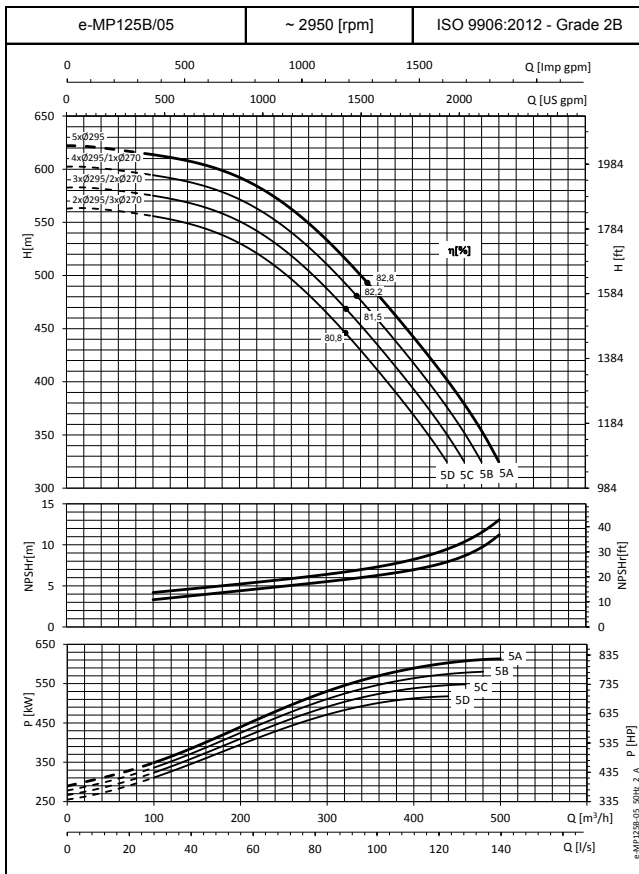

These performances are valid for cold water with density $\rho = 1 \text{ Kg/dm}^3$ and viscosity $\nu = 1 \text{ mm}^2/\text{sec}$.

e-MP50A SERIES

OPERATING CHARACTERISTICS AT 50 Hz, 4 POLES

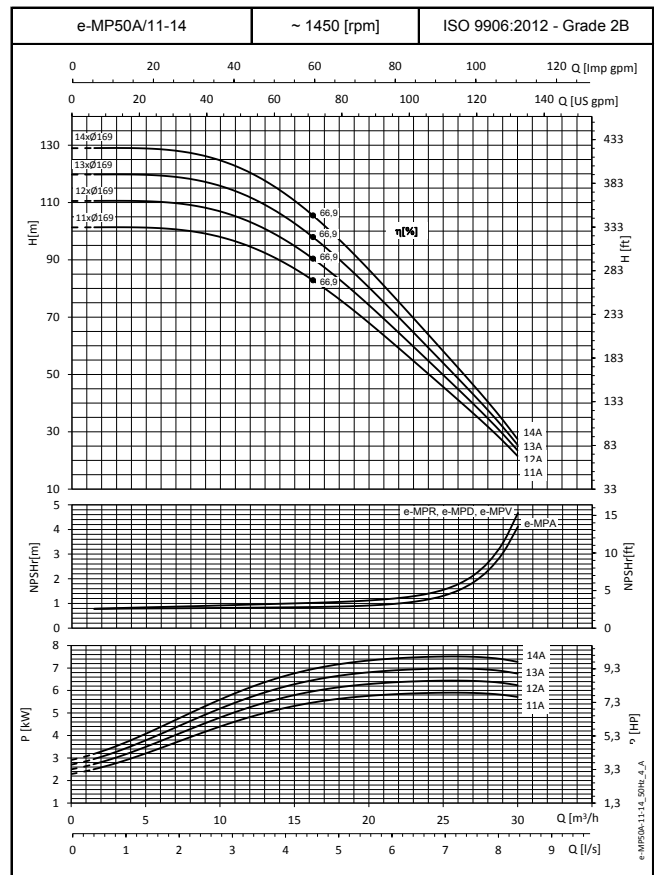
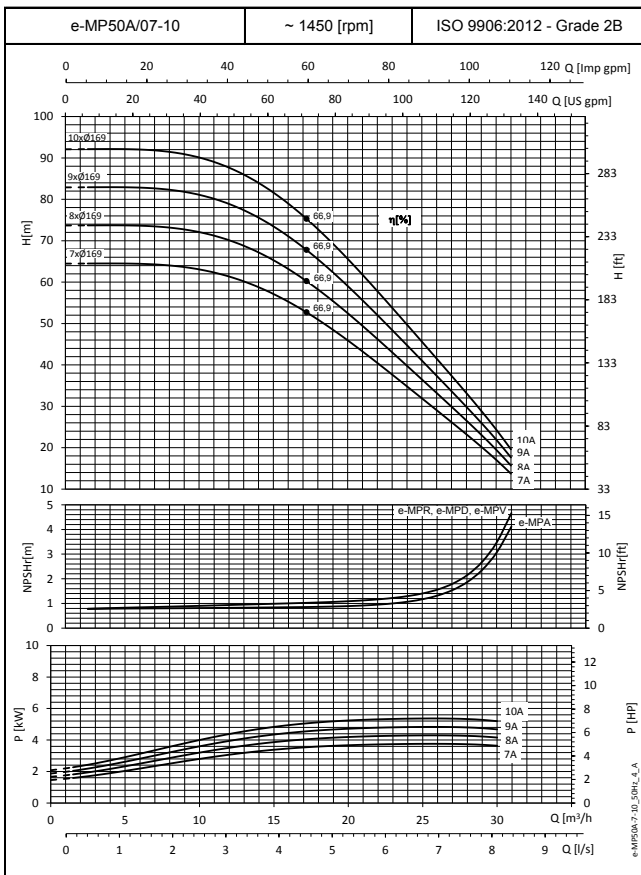
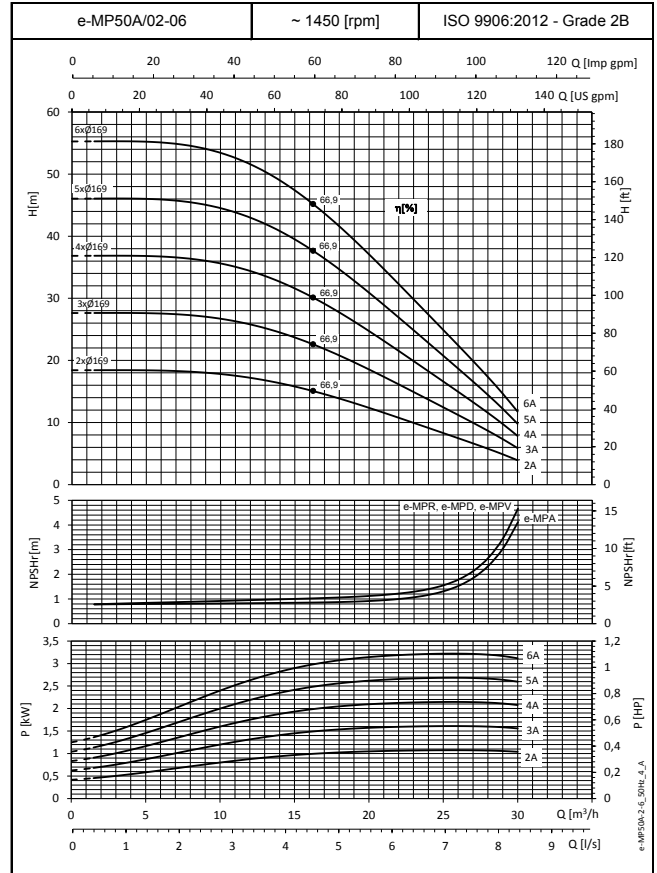
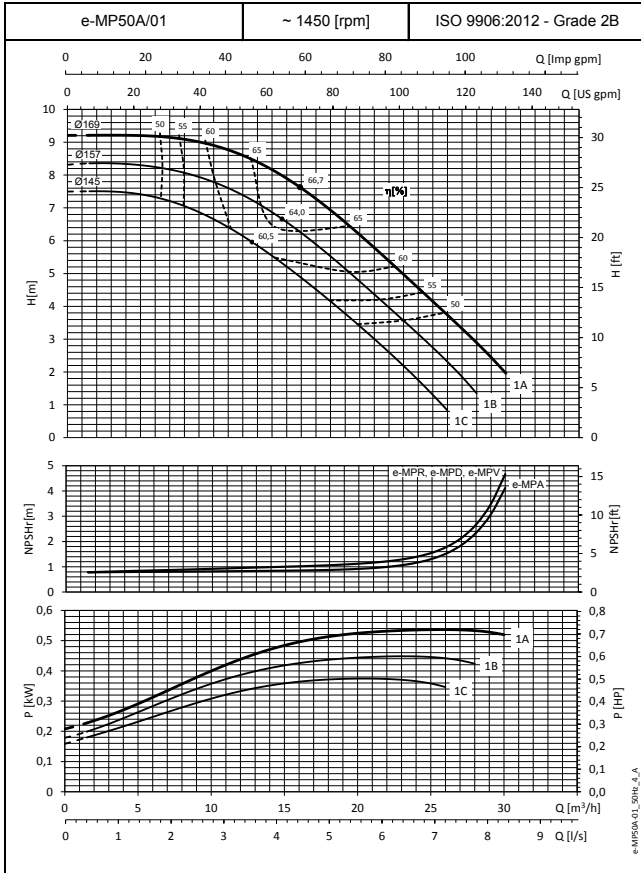

These performances are valid for cold water with density $\rho = 1 \text{ Kg/dm}^3$ and viscosity $\nu = 1 \text{ mm}^2/\text{sec}$.

e-MP50A SERIES OPERATING CHARACTERISTICS AT 50 Hz, 4 POLES

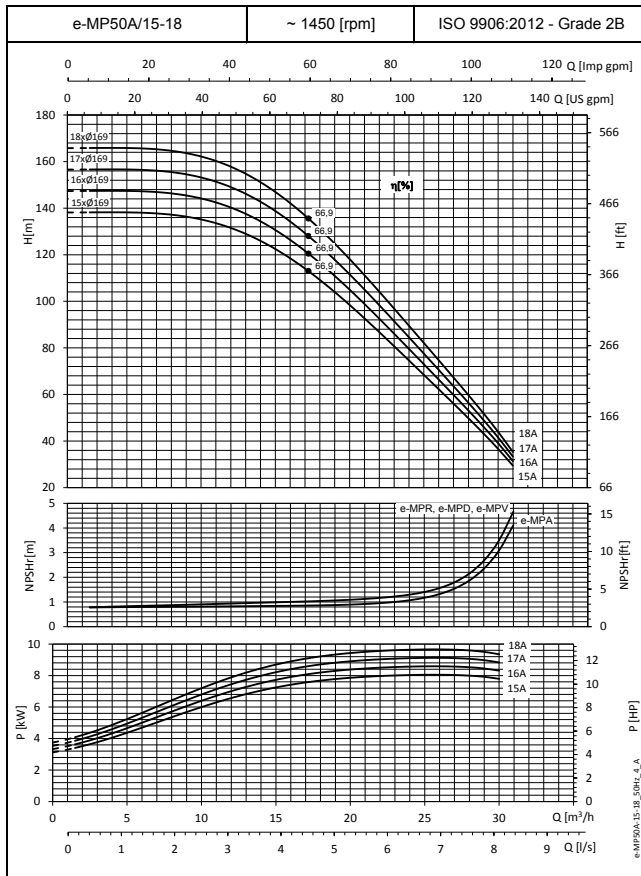

These performances are valid for cold water with density $\rho = 1 \text{ Kg/dm}^3$ and viscosity $\nu = 1 \text{ mm}^2/\text{sec}$.

e-MP50B SERIES

OPERATING CHARACTERISTICS AT 50 Hz, 4 POLES

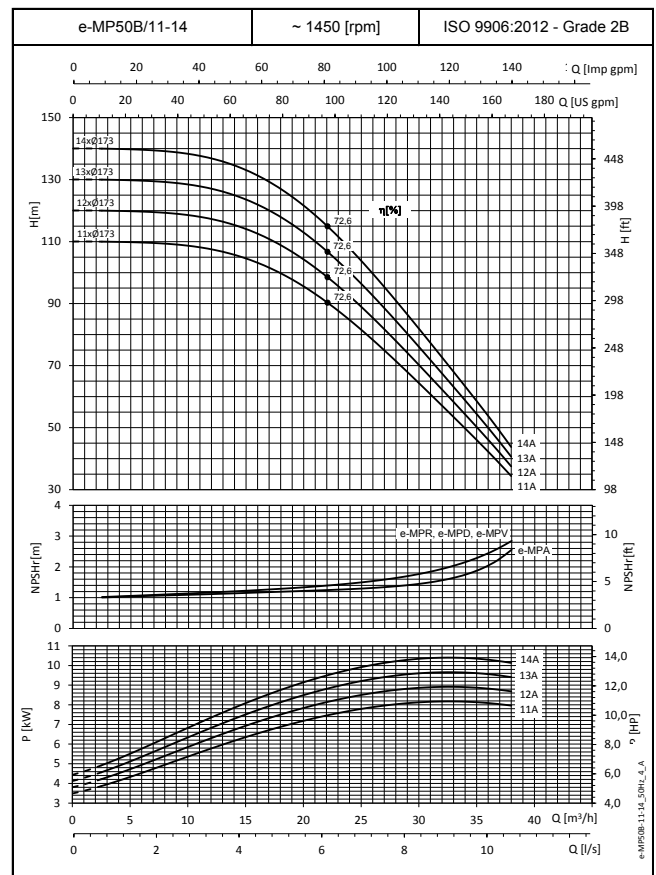
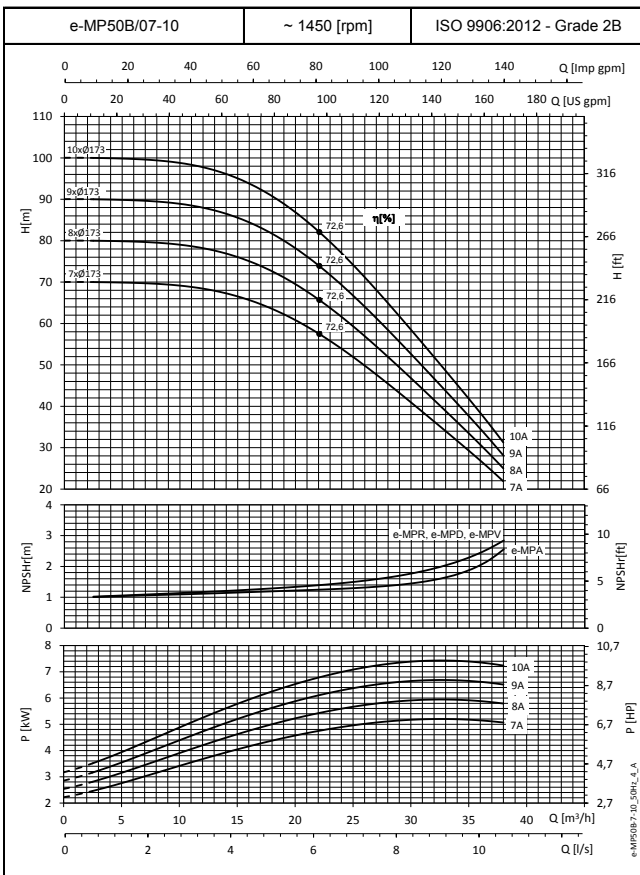
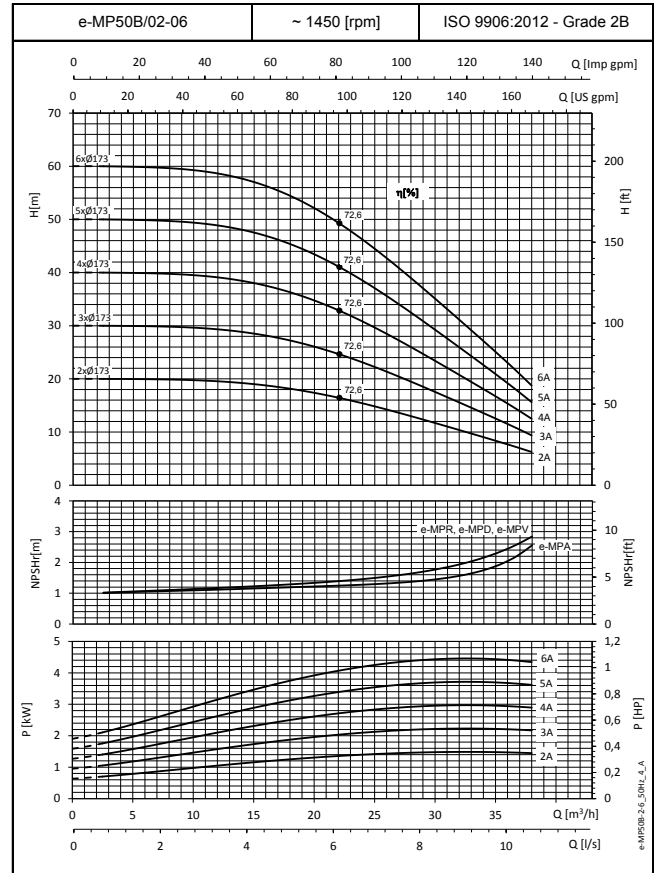
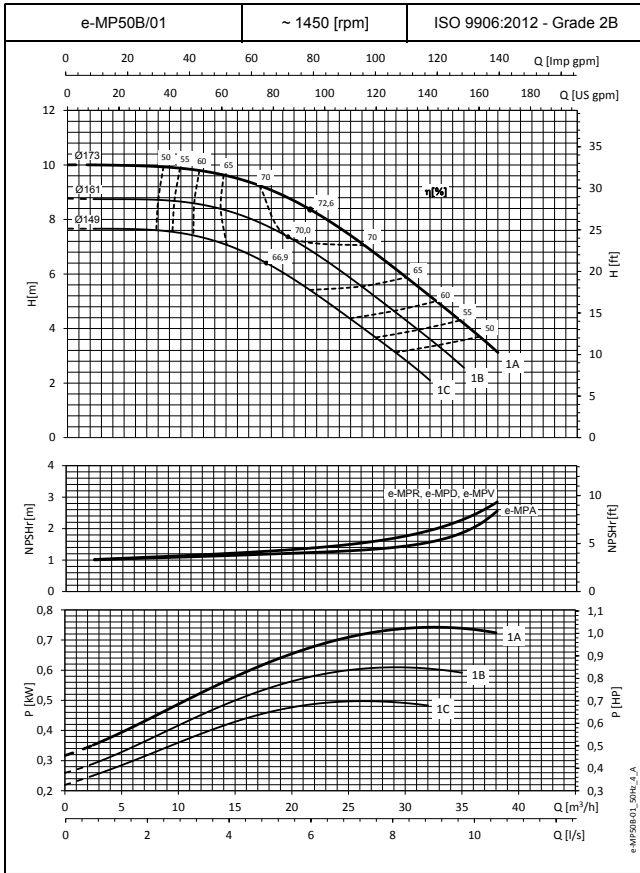

These performances are valid for cold water with density $\rho = 1 \text{ Kg/dm}^3$ and viscosity $\nu = 1 \text{ mm}^2/\text{sec}$.

**e-MP50B SERIES
OPERATING CHARACTERISTICS AT 50 Hz, 4 POLES**

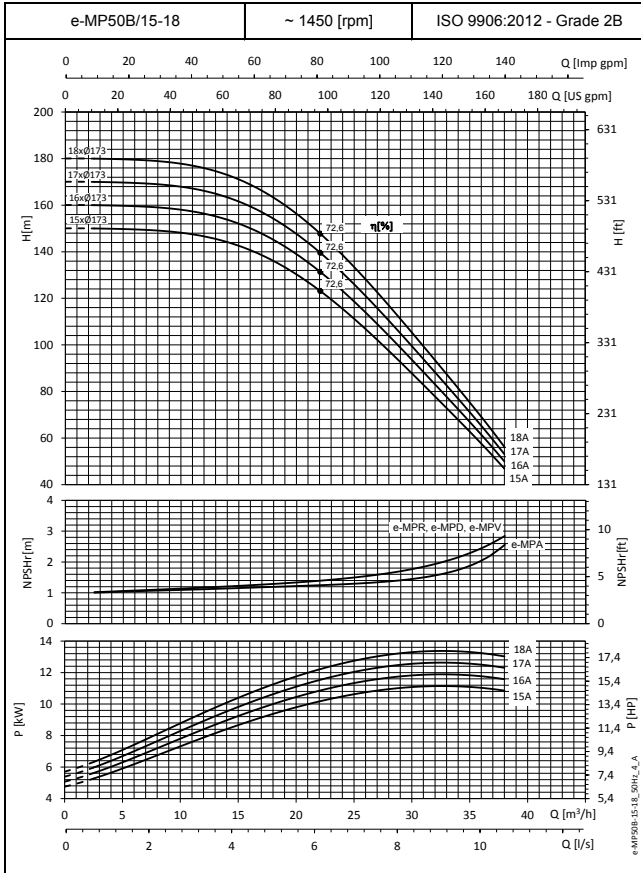

These performances are valid for cold water with density $\rho = 1 \text{ Kg/dm}^3$ and viscosity $\nu = 1 \text{ mm}^2/\text{sec}$.

e-MP65A SERIES

OPERATING CHARACTERISTICS AT 50 Hz, 4 POLES

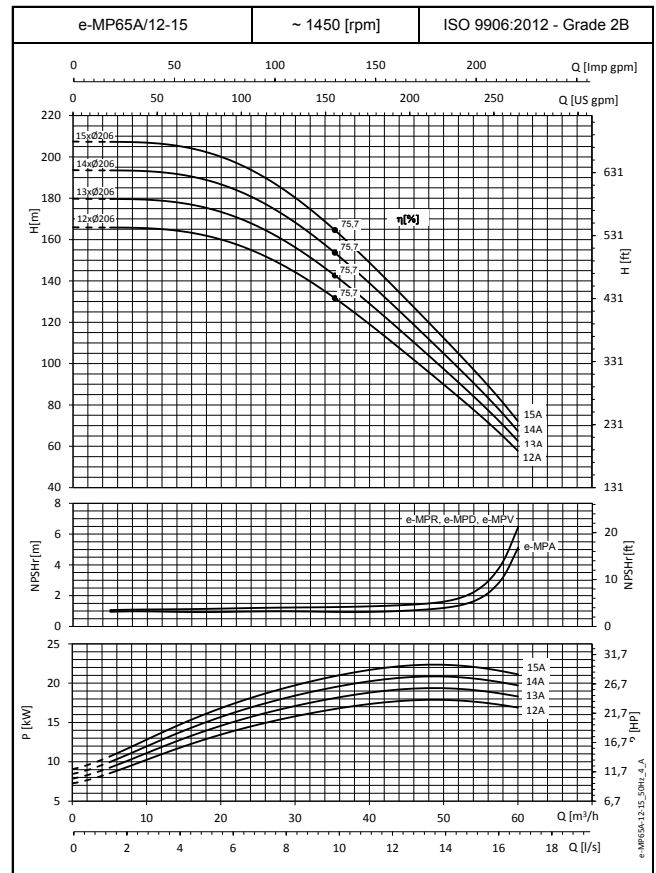
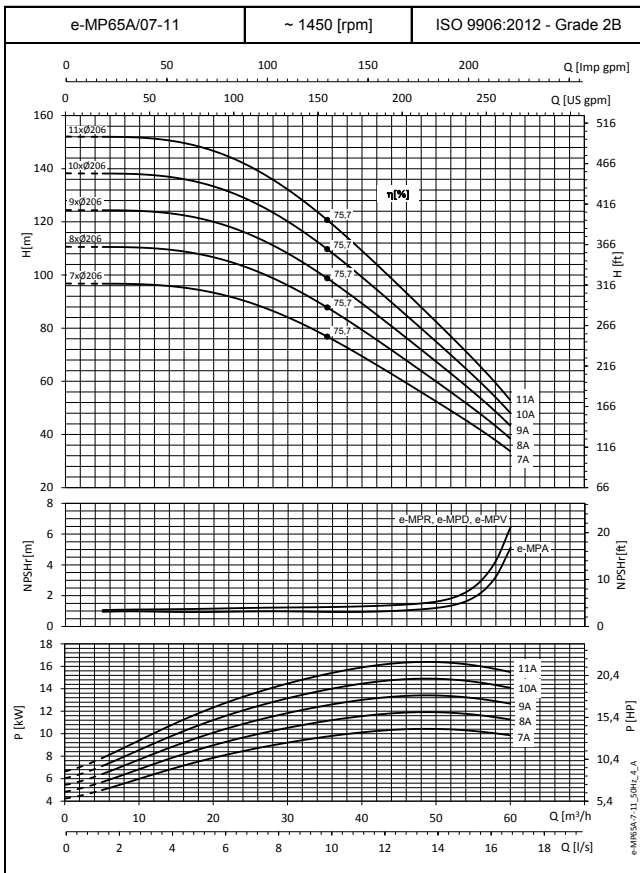
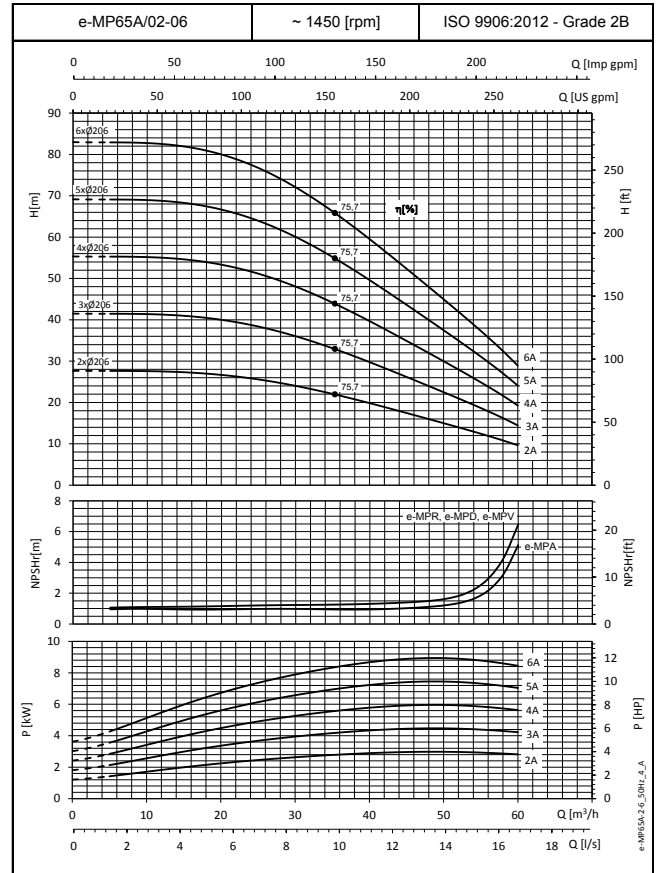
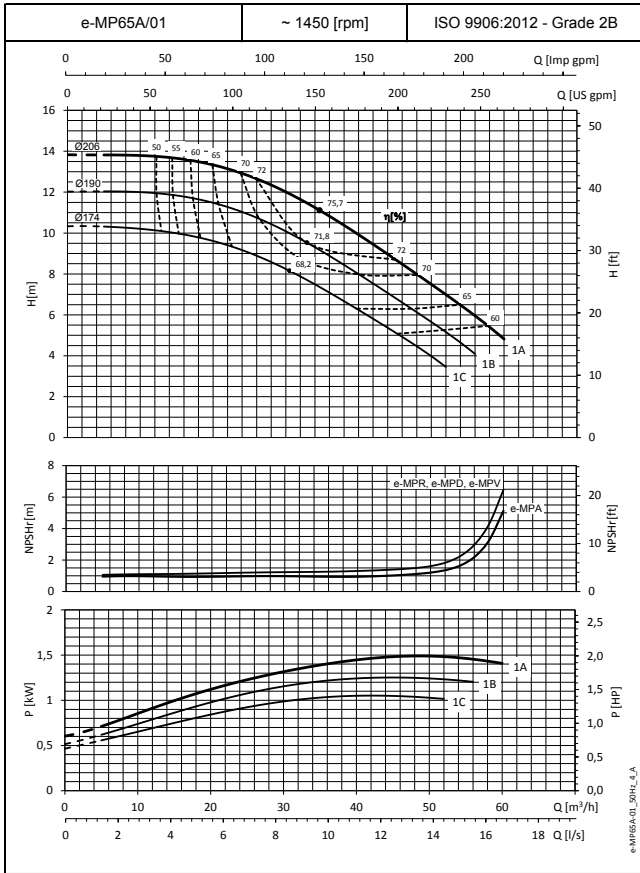

These performances are valid for cold water with density $\rho = 1 \text{ Kg/dm}^3$ and viscosity $\nu = 1 \text{ mm}^2/\text{sec}$.

e-MP65B SERIES

OPERATING CHARACTERISTICS AT 50 Hz, 4 POLES

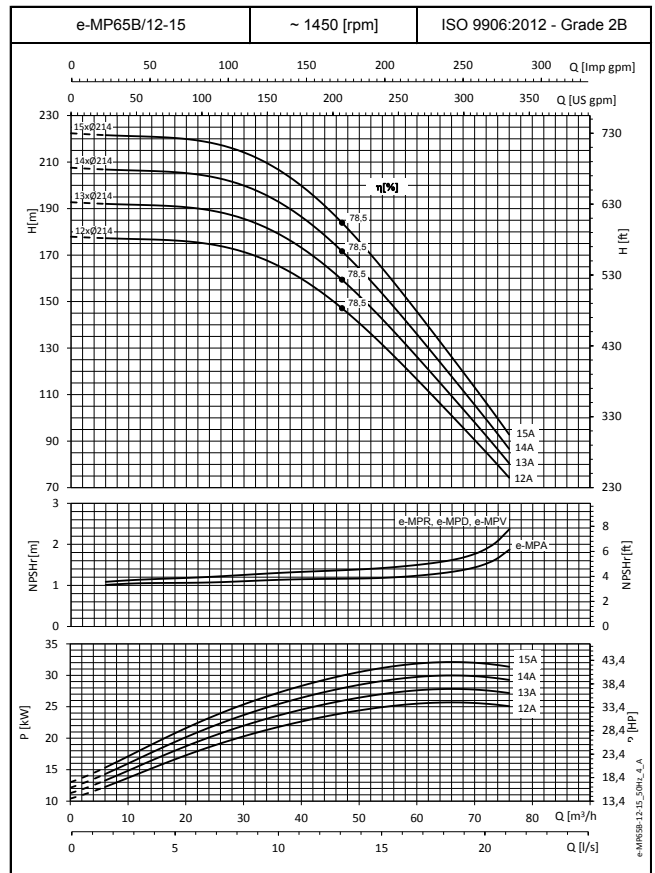
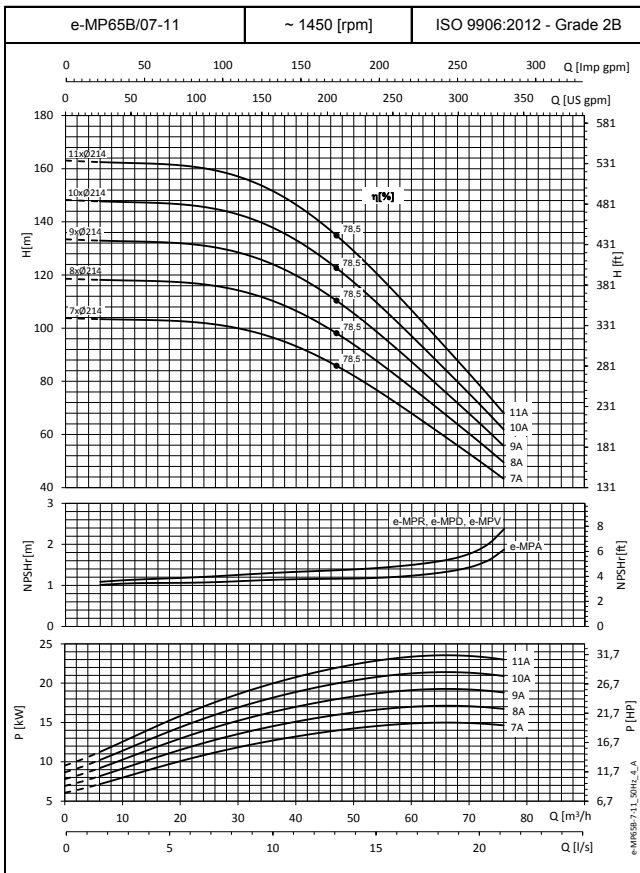
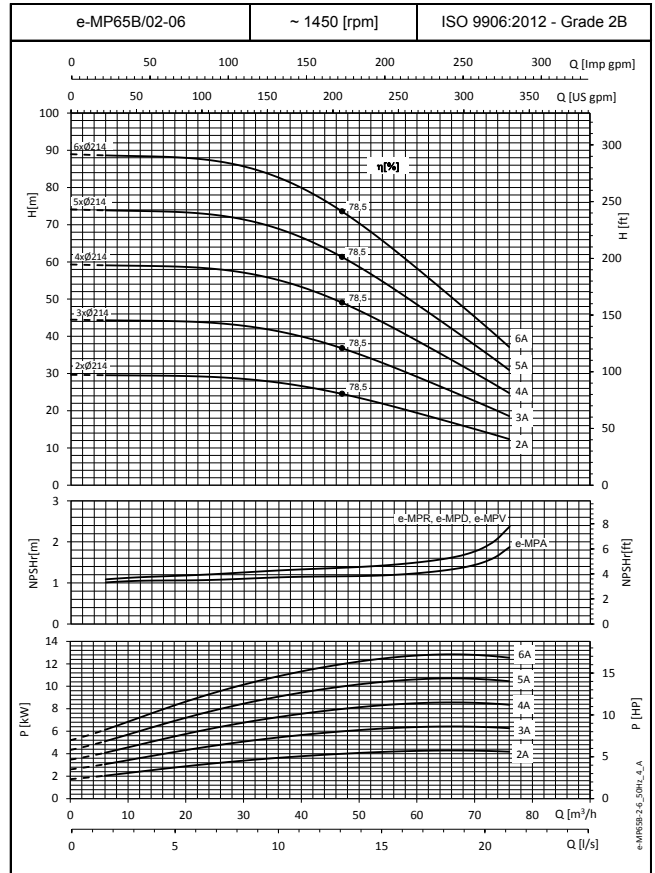
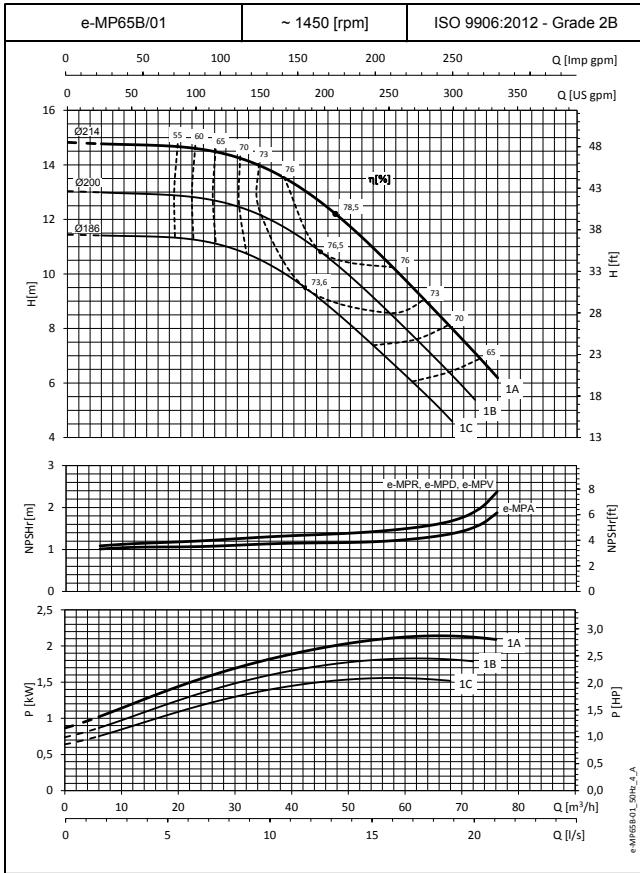

These performances are valid for cold water with density $\rho = 1 \text{ Kg/dm}^3$ and viscosity $\nu = 1 \text{ mm}^2/\text{sec}$.

e-MP100A SERIES

OPERATING CHARACTERISTICS AT 50 Hz, 4 POLES

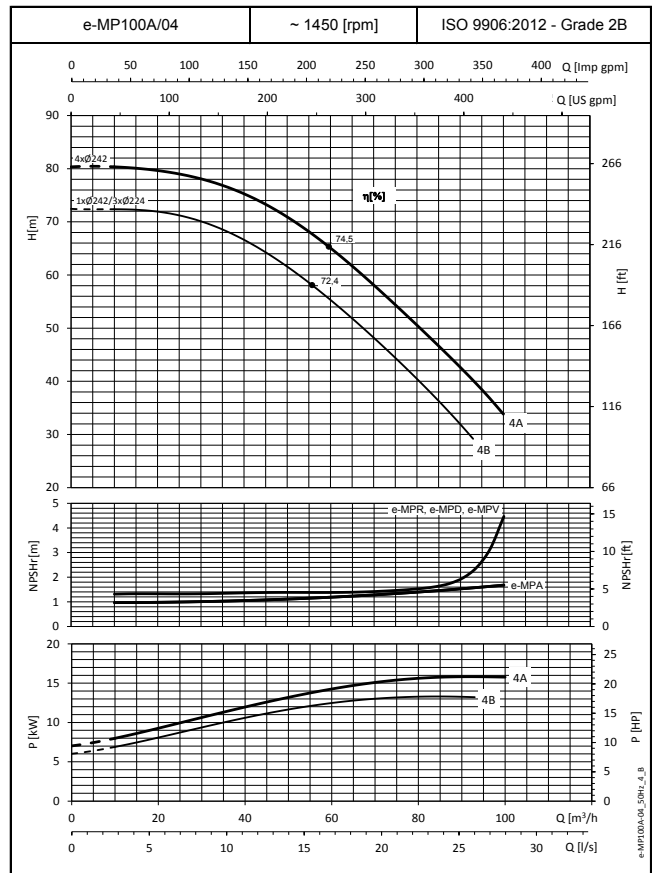
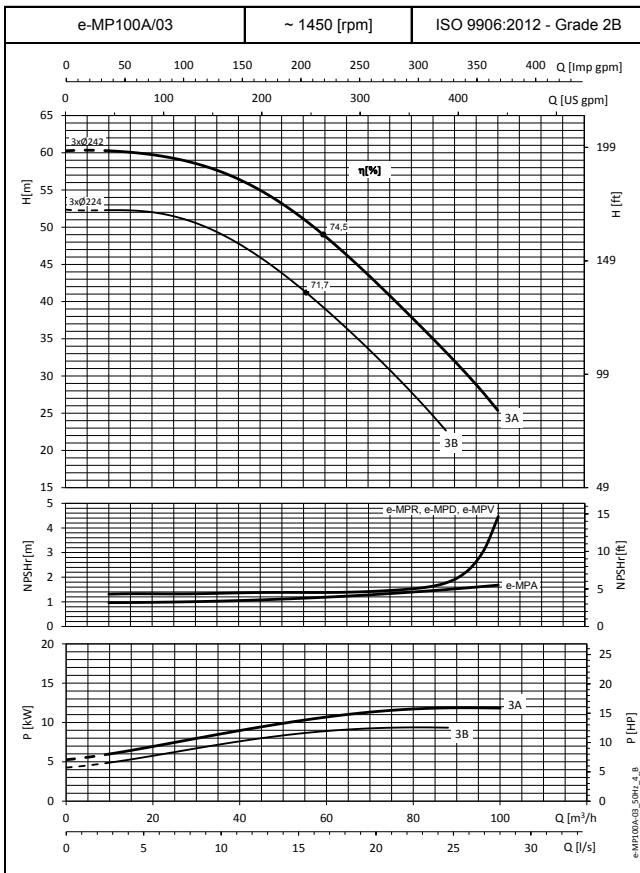
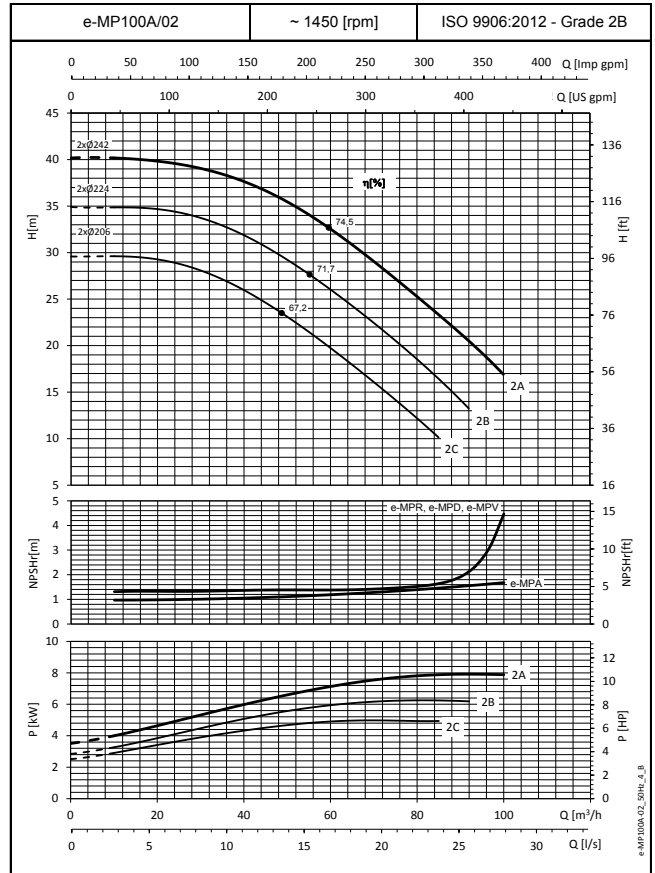
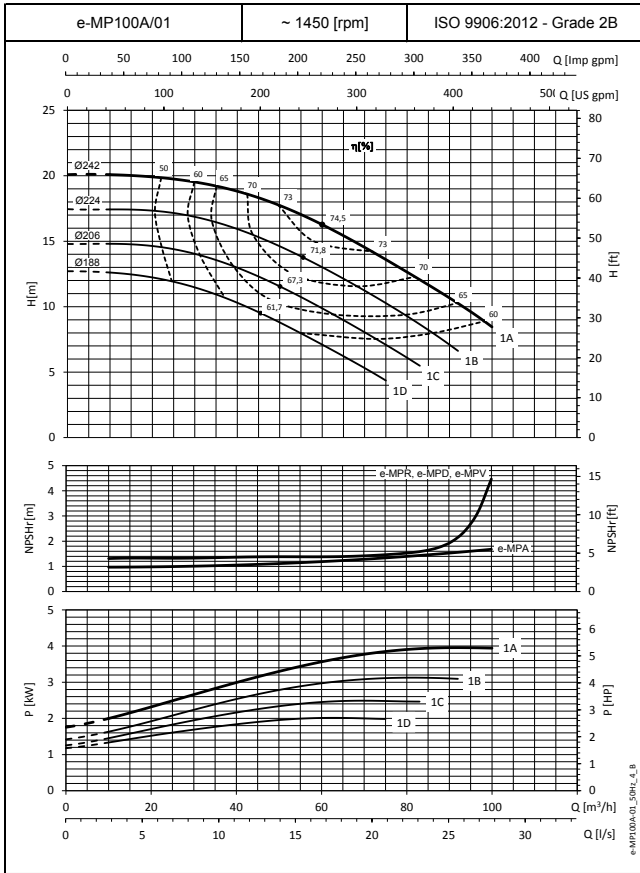

These performances are valid for cold water with density $\rho = 1 \text{ Kg/dm}^3$ and viscosity $\nu = 1 \text{ mm}^2/\text{sec}$.

e-MP100A SERIES OPERATING CHARACTERISTICS AT 50 Hz, 4 POLES

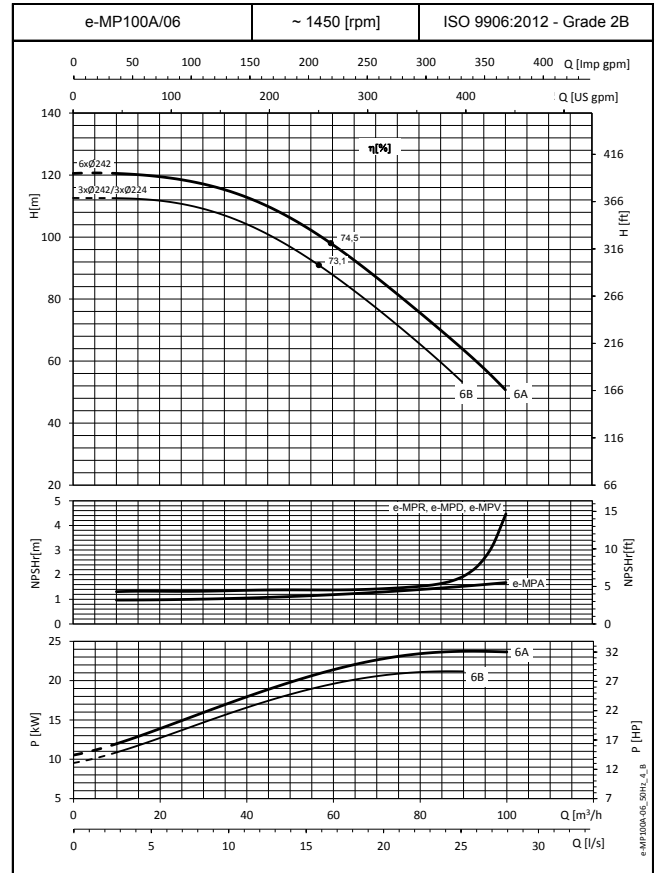
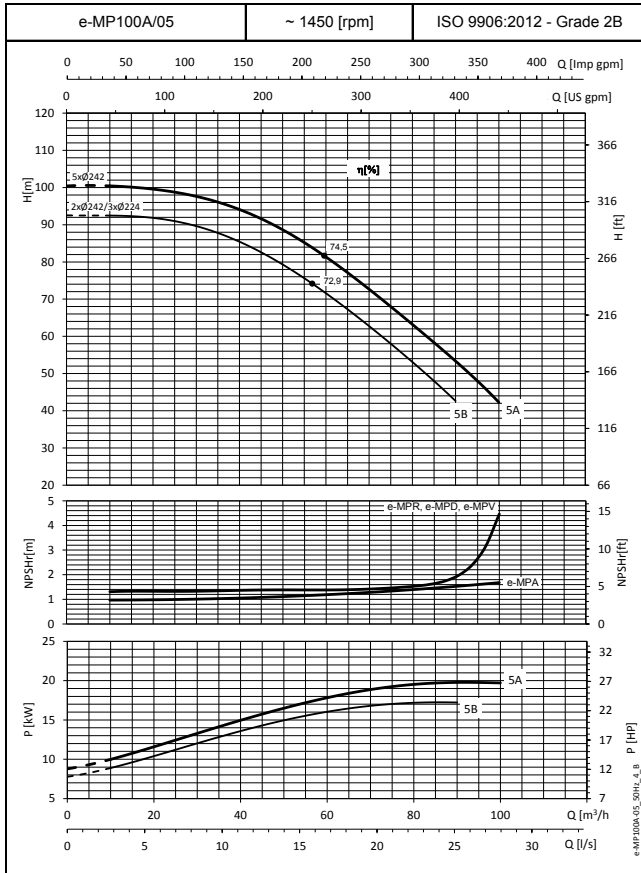

These performances are valid for cold water with density $\rho = 1 \text{ Kg/dm}^3$ and viscosity $\nu = 1 \text{ mm}^2/\text{sec}$.

e-MP100B SERIES

OPERATING CHARACTERISTICS AT 50 Hz, 4 POLES

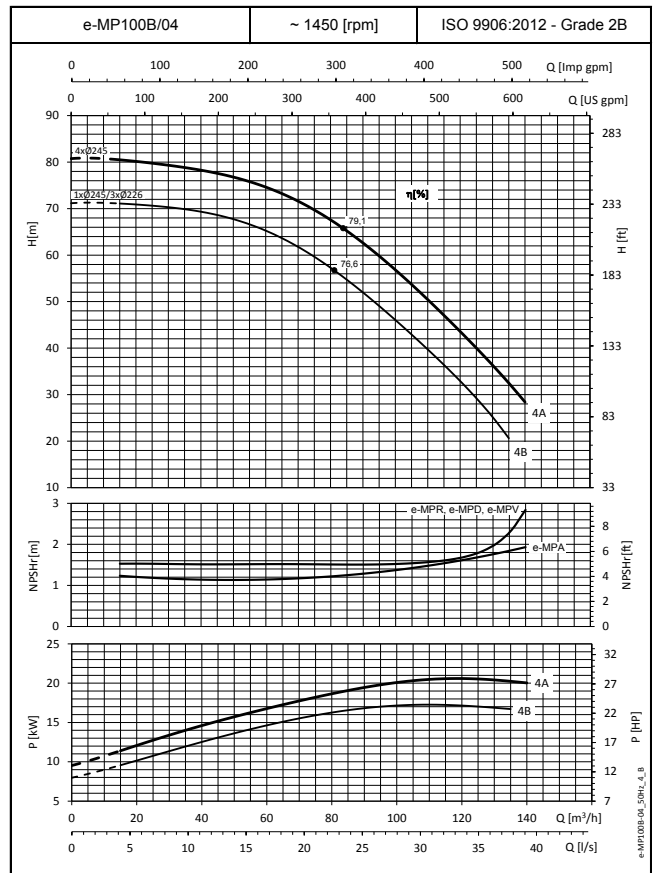
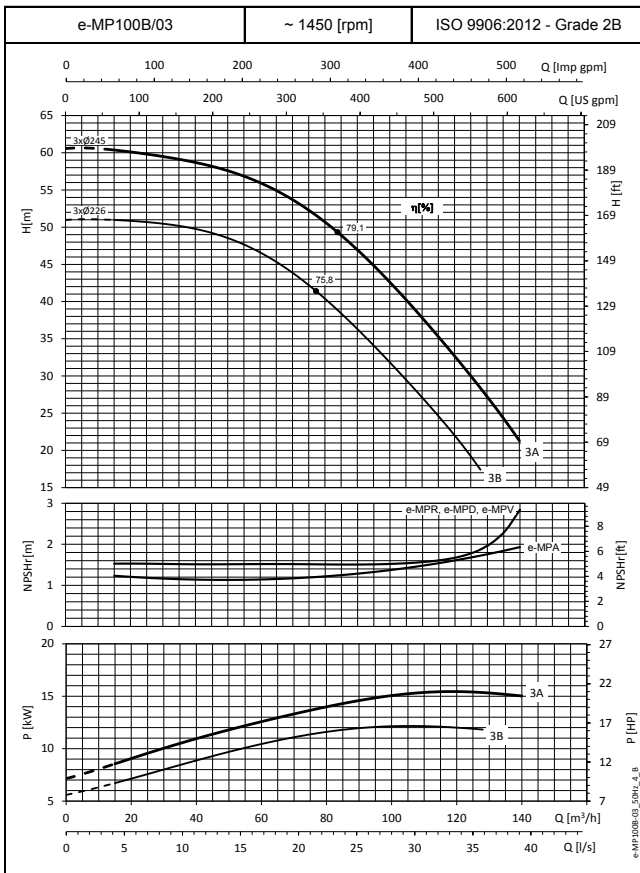
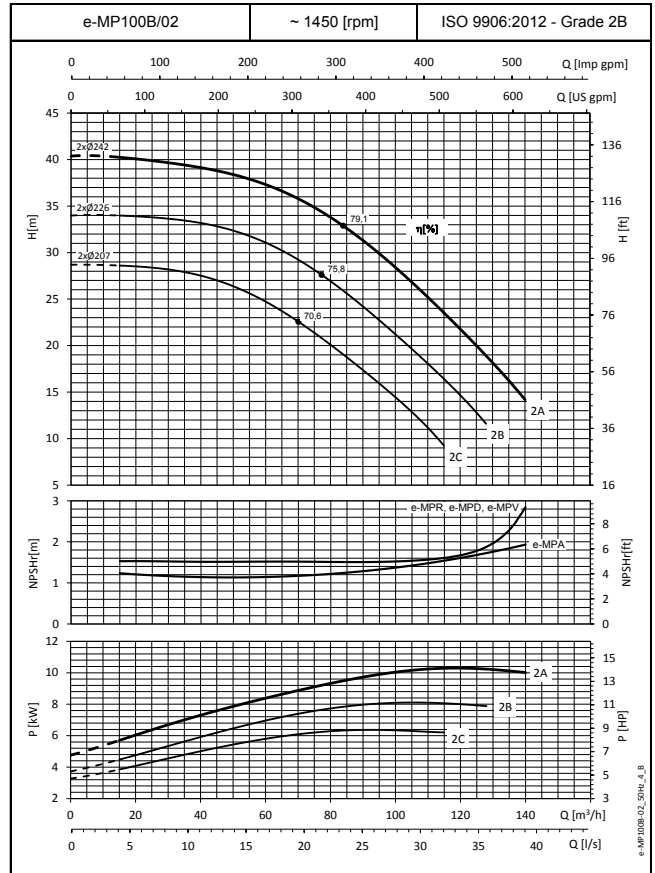
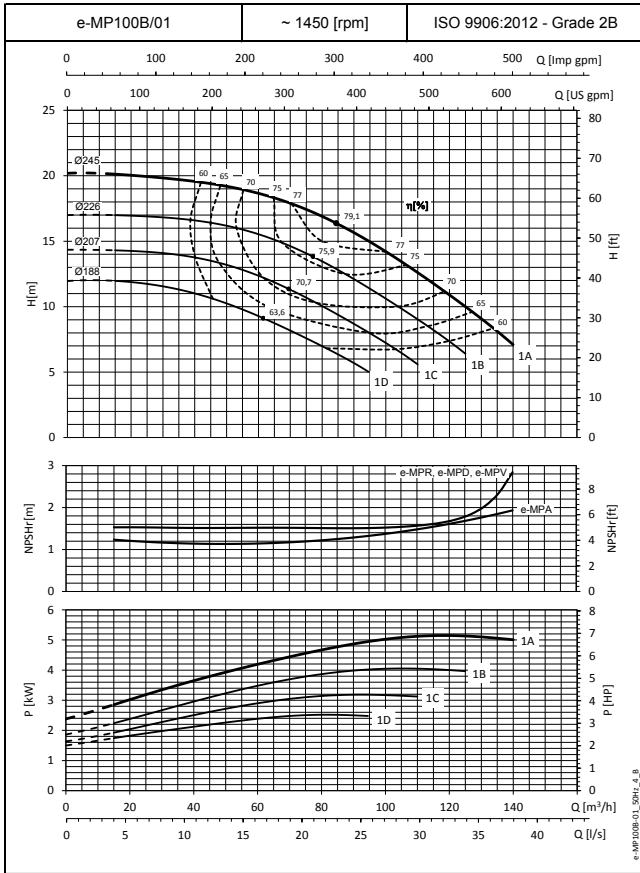

These performances are valid for cold water with density $\rho = 1 \text{ Kg/dm}^3$ and viscosity $\nu = 1 \text{ mm}^2/\text{sec}$.

e-MP100B SERIES OPERATING CHARACTERISTICS AT 50 Hz, 4 POLES

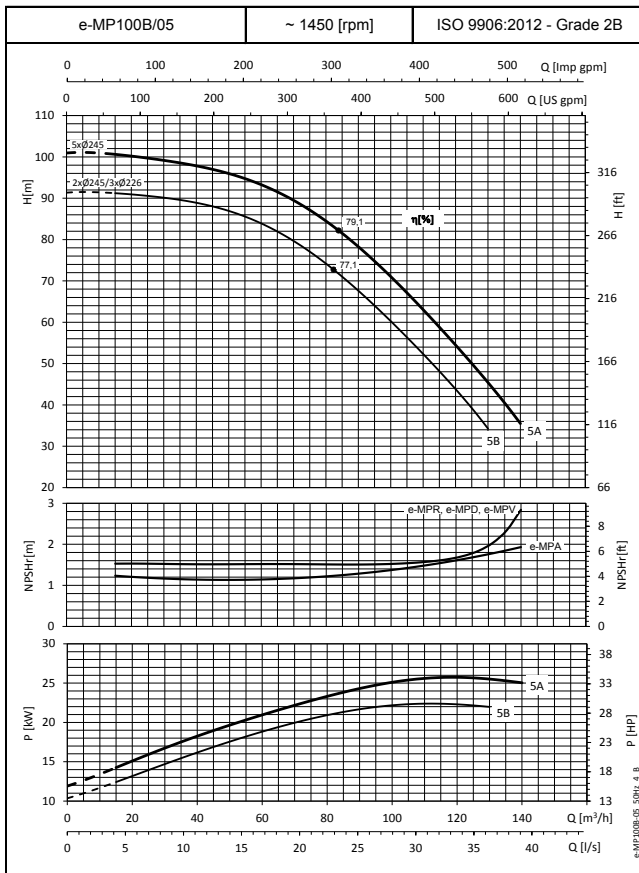
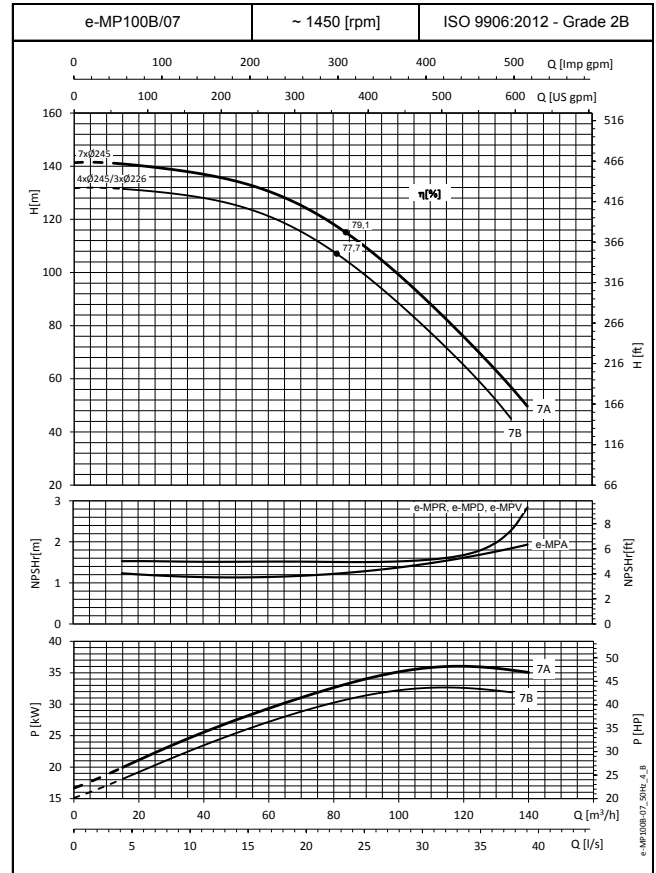
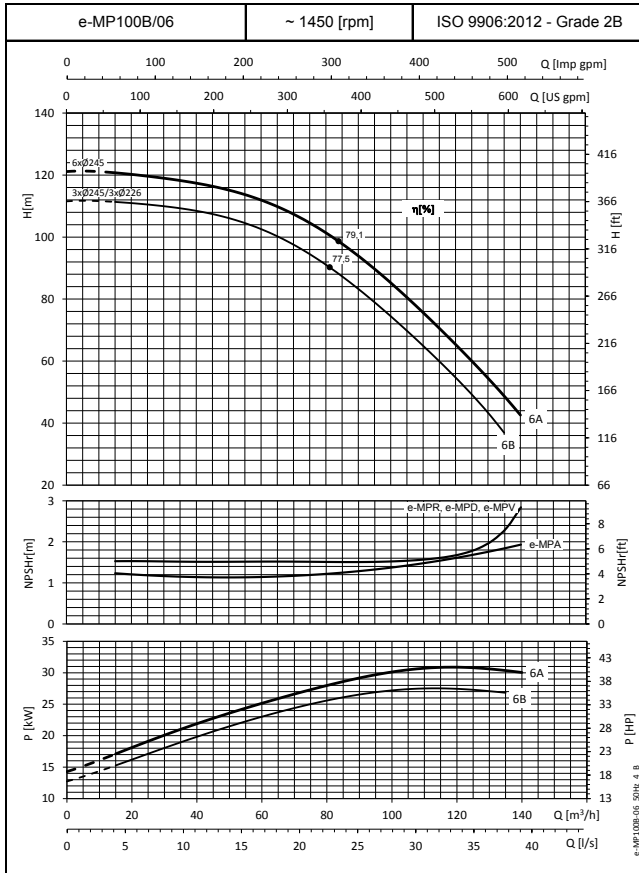

These performances are valid for cold water with density $\rho = 1 \text{ Kg/dm}^3$ and viscosity $\nu = 1 \text{ mm}^2/\text{sec}$.

e-MP125A SERIES OPERATING CHARACTERISTICS AT 50 Hz, 4 POLES

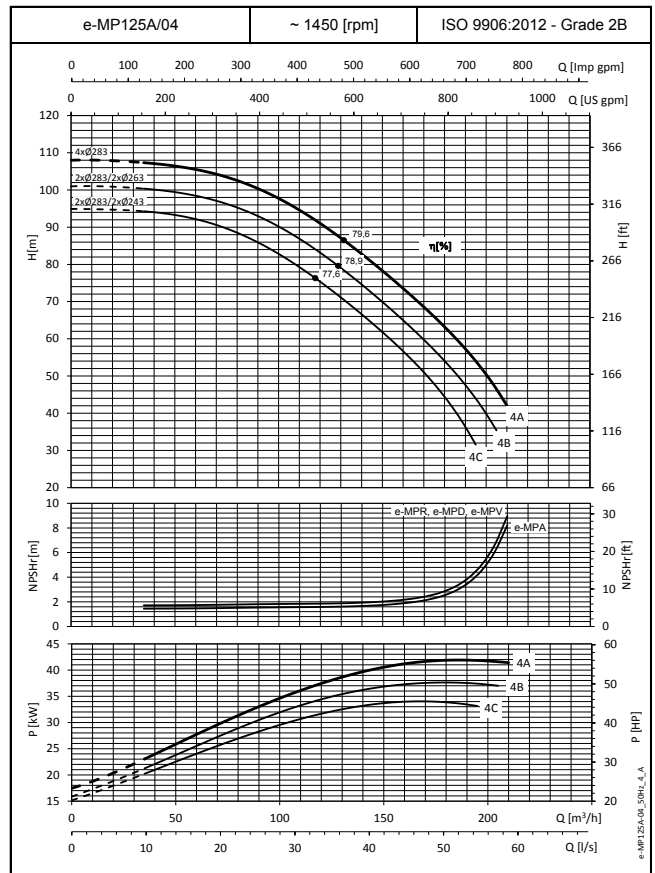
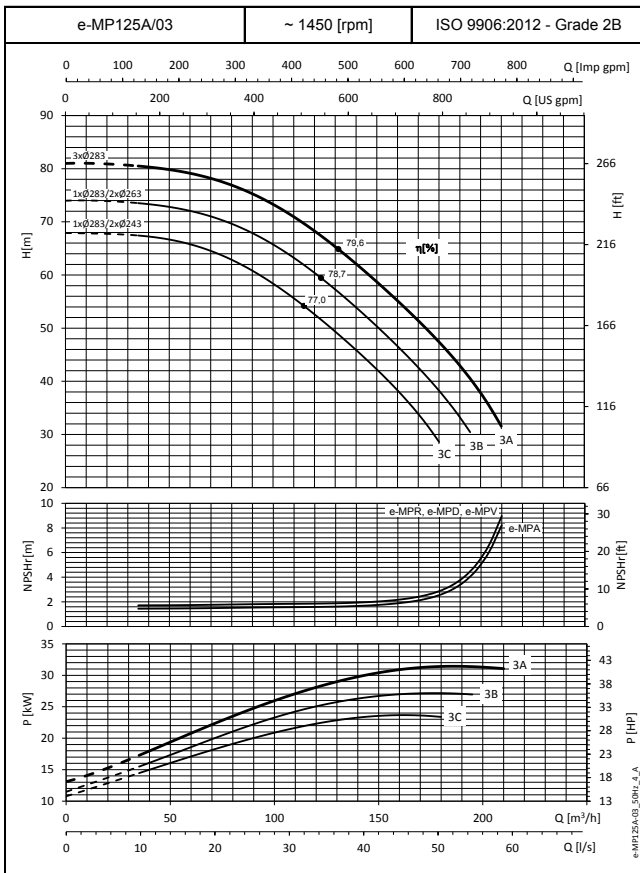
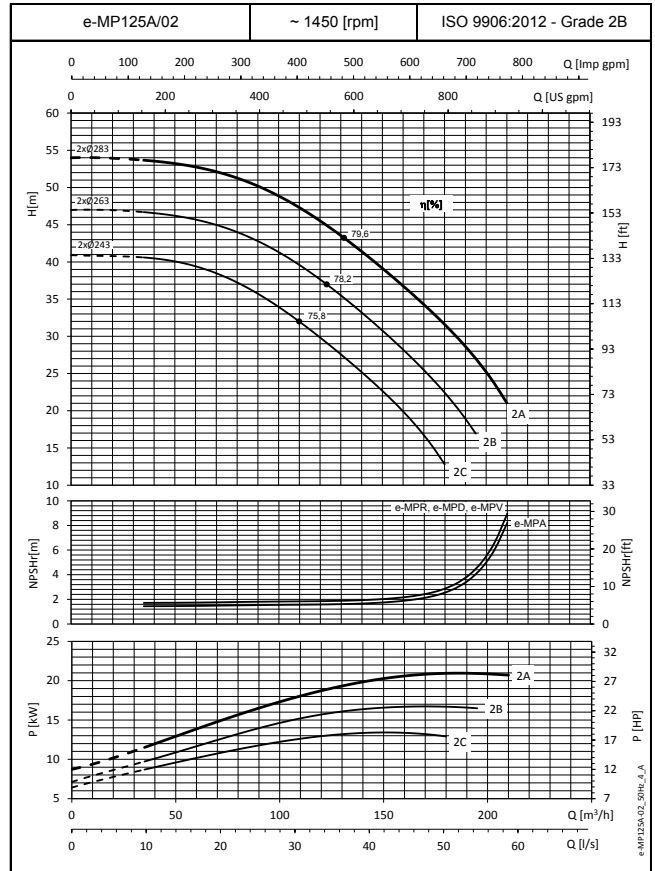
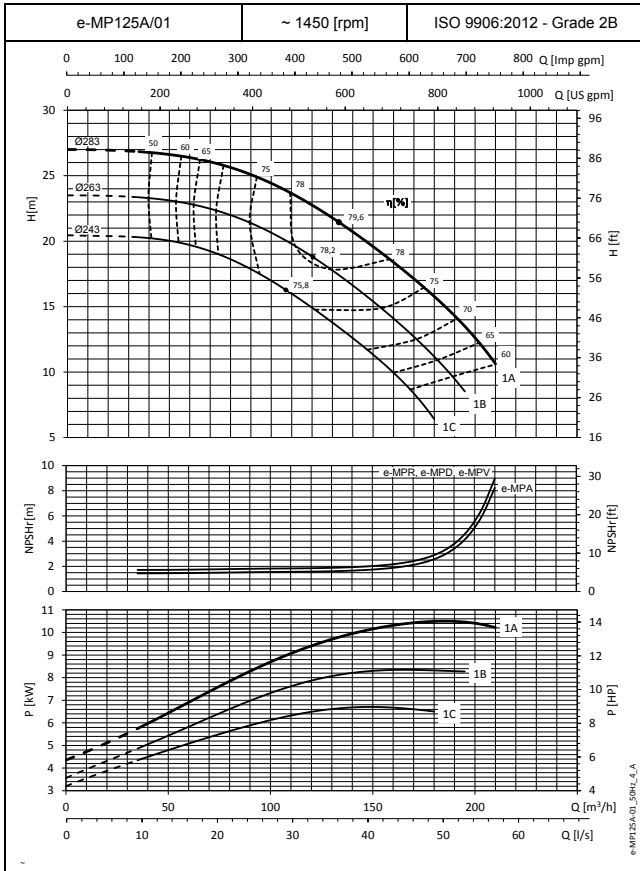

These performances are valid for cold water with density $\rho = 1 \text{ Kg/dm}^3$ and viscosity $\nu = 1 \text{ mm}^2/\text{sec}$.

e-MP125B SERIES

OPERATING CHARACTERISTICS AT 50 Hz, 4 POLES

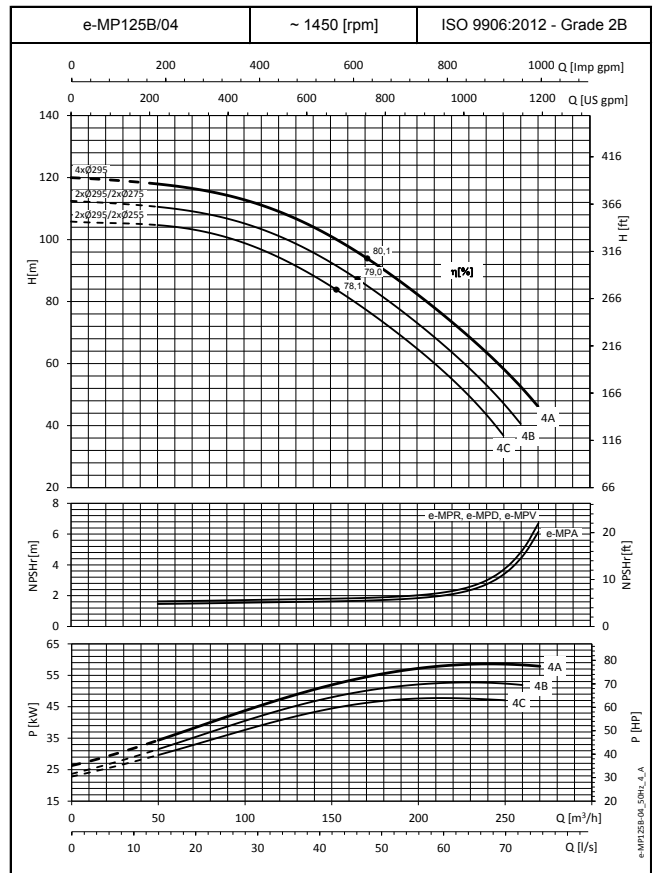
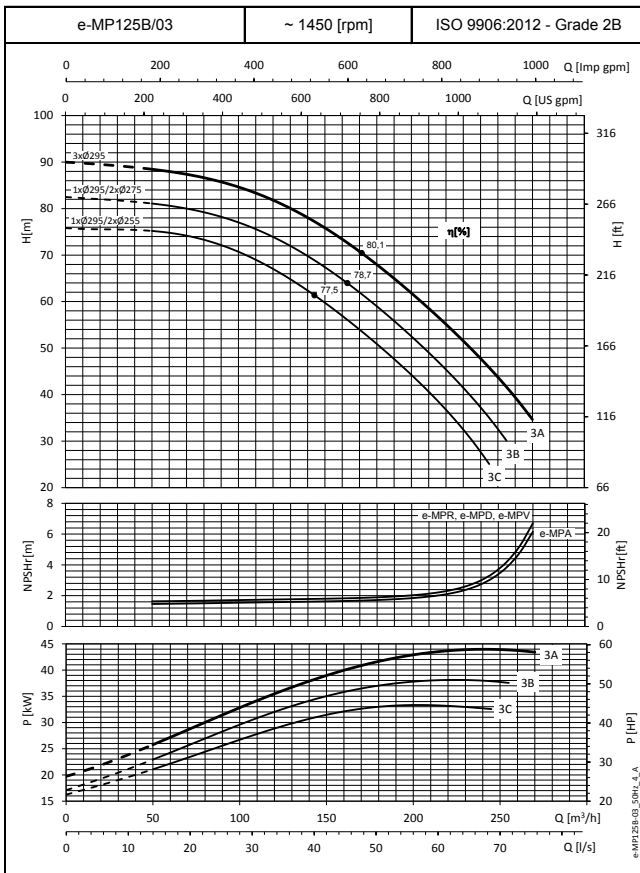
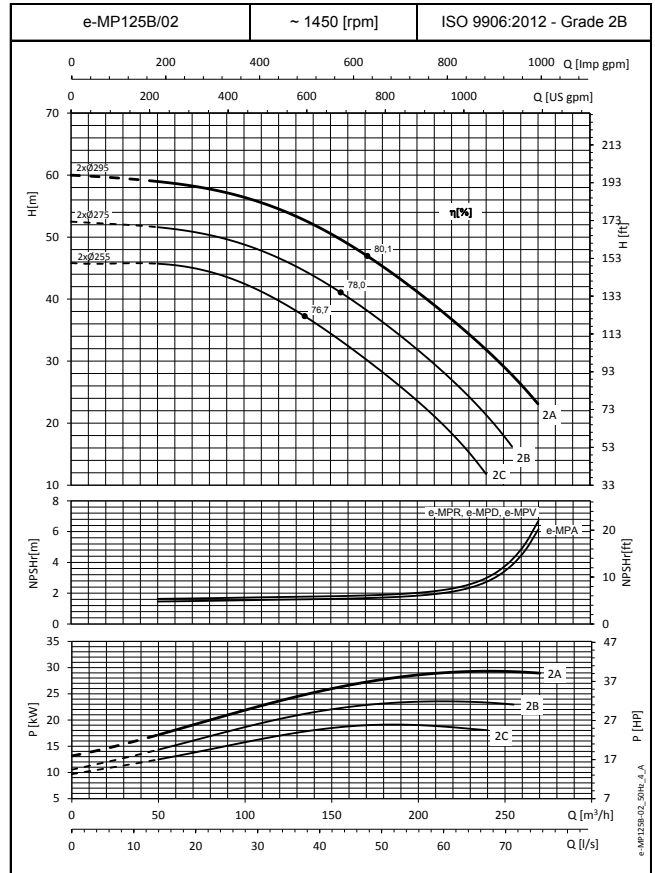
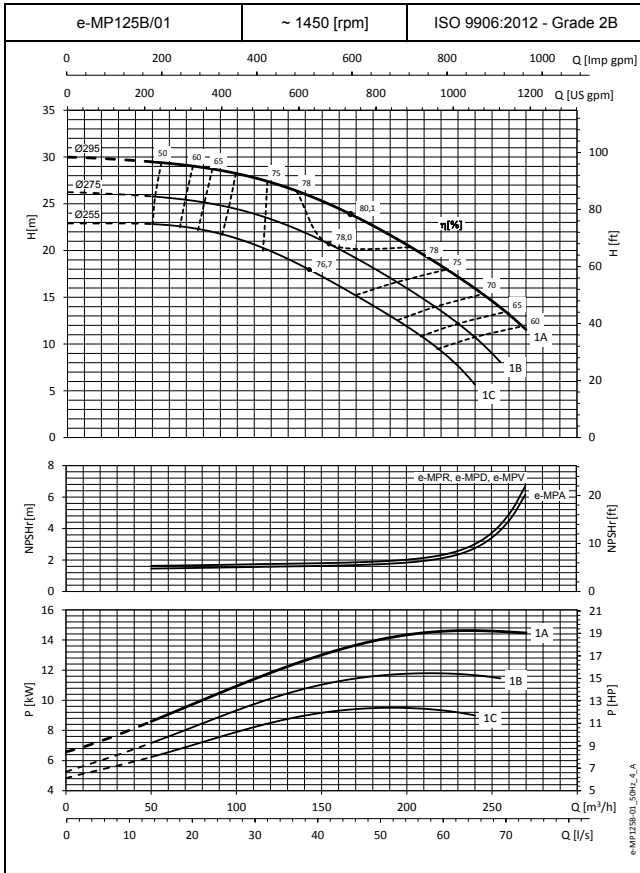

These performances are valid for cold water with density $\rho = 1 \text{ Kg/dm}^3$ and viscosity $\nu = 1 \text{ mm}^2/\text{sec}$.

DIMENSIONS AND WEIGHTS

MPA, MPD AND MPR SERIES NOZZLE POSITION

for MPA:

Code: A0

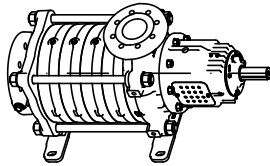

Code: AL

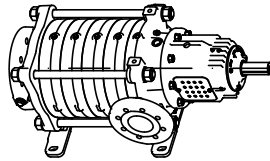

Code: AR

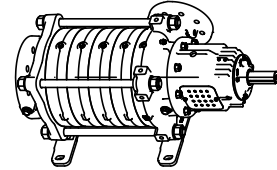

for MPD and MPR:

Code: L0

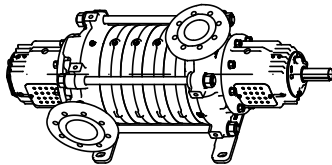

Code: R0

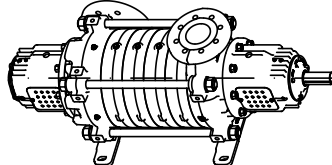

Code: 00

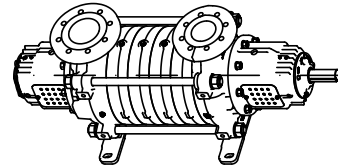

Code: LR

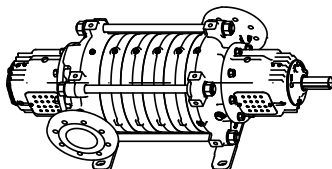

Code: OR

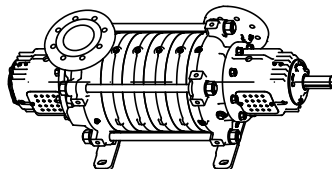

Code: RR

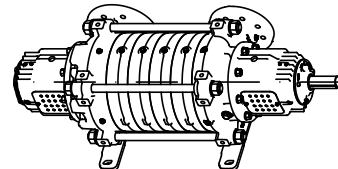

Code: RL

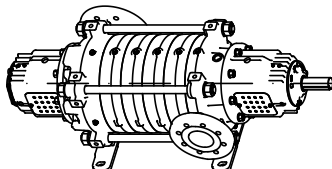

Code: 0L

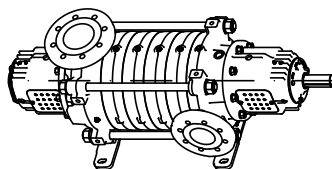

Code: LL

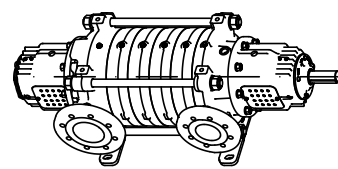

Note: Nozzle position LL, 00, RR is not possible for pumps with 1 and 2 stages

e-MP-NOZ-EN_a_DD

To be selected in Xylect

MPA SERIES DIMENSIONS AND WEIGHTS AT 50 Hz

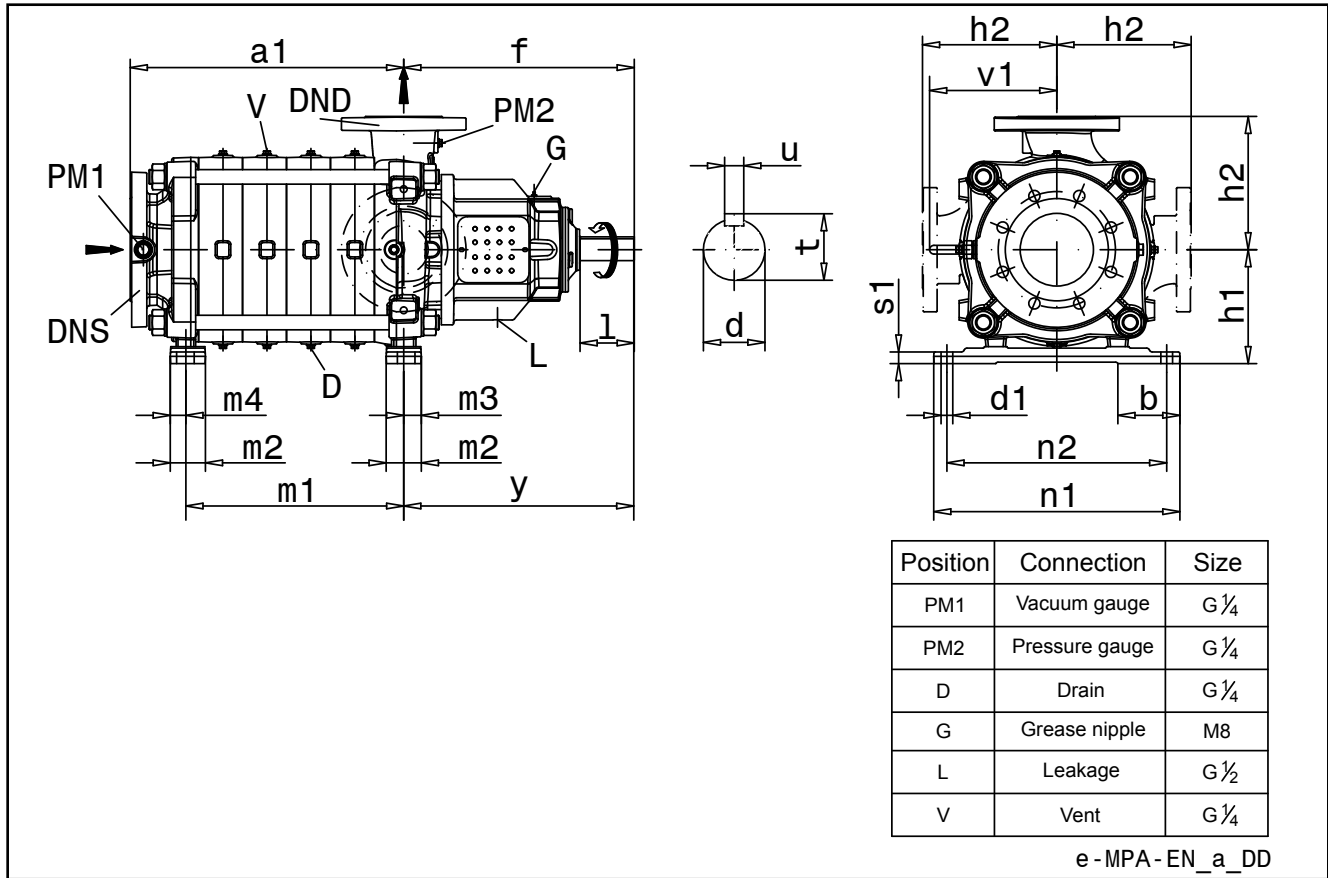

PUMP TYPE	DIMENSIONS [mm]																		
	MPA Size	Pump dimensions						Feet dimensions						Shaft end					
		DNS	DND	f	h1	h2	v1	y	m2	m3	m4	n1	n2	b	d1	s1	d	t	u
50	100	50	350	150	200	200	350	54	24	27	332	290	90	14	21	28j6	31	8	70
65	125	65	393	190	225	225	393	60	30	30	410	365	99	19	20	35k6	38	10	80
100	150	100	472	235	275	275	472	72	36	36	504	450	125	24	24	45k6	48,5	14	110
125	200	125	488	300	325	325	488	90	45	45	610	560	209	26	50	52k6	56	16	110
150	250	150	580	350	400	400	580	100	40	40	735	680	260	26	50	60m6	64	18	135

NOTE: Pumps supplied with flanges according to EN 1092-2 as standard; available ASME B16.5 version on request.
For flanges dimensions see drawing on pages 90-91.

e-MPA-en_a_td

SIZE NUMBER OF STAGES	50			65			100			125			150		
	a1	m1	G [kg]	a1	m1	G [kg]	a1	m1	G [kg]	a1	m1	G [kg]	a1	m1	G [kg]
2	200	116	89	248	145	141	290	176	242	388	219	430	442	277	-
3	262	178	101	326	223	165	380	266	280	500	331	497	574	409	-
4	324	240	113	404	301	189	470	356	318	612	443	564	706	541	-
5	386	302	125	482	379	213	560	446	356	724	555	631	838	673	-
6	448	364	137	560	457	237	650	536	394	836	667	698	970	805	-
7	510	426	149	638	535	261	740	626	432	948	779	765			
8	572	488	161	716	613	285	830	716	470	1060	891	832			
9	634	550	173	794	691	309	920	806	508						
10	696	612	185	872	769	333	1010	896	546						
11	758	674	197	950	847	357	1100	986	584						
12	820	736	209	1028	925	381									
13	882	798	221	1106	1003	405									
14	944	860	233	1184	1081	429									
15	1006	922	245	1262	1159	453									
16	1068	984	257												
17	1130	1046	269												
18	1192	1108	281												

e-MPA-stage-en_a_td

MPA SERIES
DIMENSIONS AND WEIGHTS AT 50 Hz

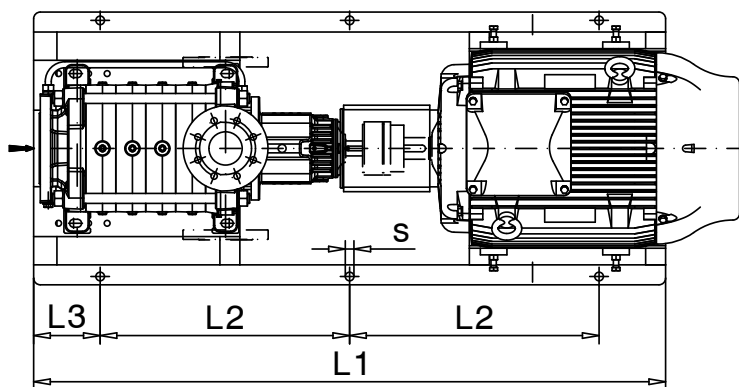
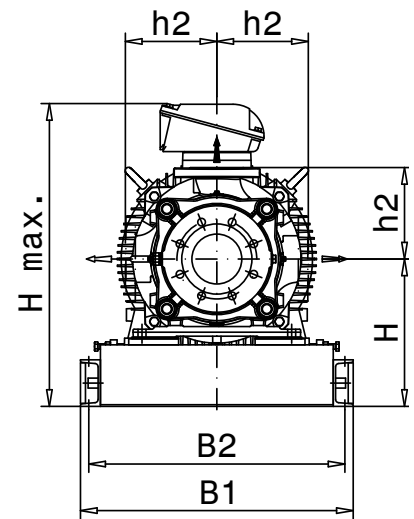
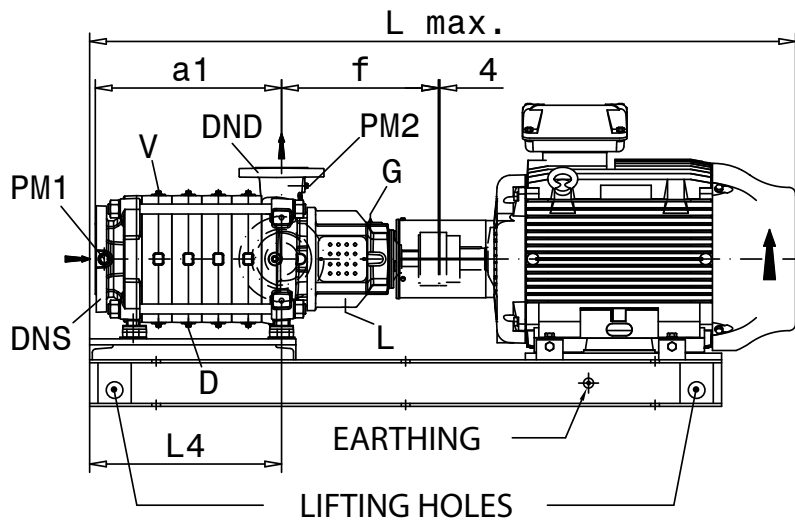

Position	Connection	Size
PM1	Vacuum gauge	G ¼
PM2	Pressure gauge	G ¼
D	Drain	G ¼
G	Grease nipple	M8
L	Leakage	G ½
V	Vent	G ¼

e-MPA-AS-EN a DD

MPA SERIES - Size 50 DIMENSIONS AND WEIGHTS AT 50 Hz

PUMP TYPE MPA Size	NUMBER OF STAGES	IEC MOTOR FRAME	3000 [rpm]	1500 [rpm]	DIMENSIONS [mm]														WEIGHT G [kg]	COUPLING TYPE	
					DNS	DND	a1	f	B1	B2	L1	L2	L3	L4	H	h2	s	Hmax			Lmax
50	2	132S/M	5,5	-	100	50	200	350	490	450	950	325	150	204	250	200	6xØ19 (M16)	450	1005	195	B80B
		132S/M	7,5	-	100	50	200	350	490	450	950	325	150	204	250	200	6xØ19 (M16)	450	1005	191	B80B
		160M	11	-	100	50	200	350	490	450	1100	350	200	204	288	200	6xØ19 (M16)	528	1162	259	B95A
		160M	15	-	100	50	200	350	490	450	1100	350	200	204	288	200	6xØ19 (M16)	528	1162	260	B95A
		100L	-	2,2	100	50	200	350	484	450	850	275	150	204	233	200	6xØ15 (M12)	433	1000	167	B80A
	3	160M	11	-	100	50	262	350	490	450	1200	400	200	328	288	200	6xØ19 (M16)	528	1286	275	B95A
		160M	15	-	100	50	262	350	490	450	1200	400	200	328	288	200	6xØ19 (M16)	528	1286	276	B95A
		160L	18,5	-	100	50	262	350	490	450	1200	400	200	328	288	200	6xØ19 (M16)	528	1286	283	B95A
		180M	22	-	100	50	262	350	490	450	1200	400	200	266	308	200	6xØ19 (M16)	589	1284	346	B110B
		100L	-	2,2	100	50	262	350	484	450	1000	350	150	328	233	200	6xØ15 (M12)	433	1124	184	B80A
	4	100L	-	3	100	50	262	350	484	450	1000	350	150	328	233	200	6xØ15 (M12)	433	1124	188	B80A
		160M	15	-	100	50	324	350	490	450	1200	400	200	328	288	200	6xØ19 (M16)	528	1286	288	B95A
		160L	18,5	-	100	50	324	350	490	450	1200	400	200	328	288	200	6xØ19 (M16)	528	1286	295	B95A
		180M	22	-	100	50	324	350	490	450	1300	450	200	390	308	200	6xØ19 (M16)	589	1408	363	B110B
		200L	30	-	100	50	324	350	650	610	1300	450	200	328	328	200	6xØ19 (M16)	647	1449	452	B125A
	5	100L	-	3	100	50	324	350	484	450	1000	350	150	328	233	200	6xØ15 (M12)	433	1124	200	B80A
		112M	-	4	100	50	324	350	484	450	1050	375	150	390	233	200	6xØ15 (M12)	433	1186	218	B80A
		180M	22	-	100	50	386	350	490	450	1300	450	200	390	308	200	6xØ19 (M16)	589	1408	375	B110B
		200L	30	-	100	50	386	350	650	610	1450	525	200	452	328	200	6xØ19 (M16)	647	1573	476	B125A
		200L	37	-	100	50	386	350	650	610	1450	525	200	452	328	200	6xØ19 (M16)	647	1573	491	B125A
	6	100L	-	3	100	50	386	350	484	450	1100	400	150	452	233	200	6xØ15 (M12)	433	1248	213	B80A
		112M	-	4	100	50	386	350	484	450	1050	375	150	390	233	200	6xØ15 (M12)	433	1186	230	B80A
		200L	30	-	100	50	448	350	650	610	1450	525	200	452	328	200	6xØ19 (M16)	647	1573	488	B125A
		200L	37	-	100	50	448	350	650	610	1450	525	200	452	328	200	6xØ19 (M16)	647	1573	503	B125A
		112M	-	4	100	50	448	350	484	450	1200	450	150	514	233	200	6xØ15 (M12)	433	1310	245	B80A
	7	132S/M	-	5,5	100	50	448	350	490	450	1200	450	150	452	250	200	6xØ19 (M16)	450	1291	257	B80B
		200L	30	-	100	50	510	350	650	610	1550	575	200	576	328	200	6xØ19 (M16)	647	1697	501	B125A
		200L	37	-	100	50	510	350	650	610	1550	575	200	576	328	200	6xØ19 (M16)	647	1697	516	B125A
		225S/M	45	-	100	50	510	350	660	610	1600	600	200	576	368	200	6xØ19 (M16)	752	1786	672	B125A
		112M	-	4	100	50	510	350	484	450	1200	450	150	514	233	200	6xØ15 (M12)	433	1310	257	B80A
	8	132S/M	-	5,5	100	50	510	350	490	450	1350	525	150	576	250	200	6xØ19 (M16)	450	1415	272	B80B
		132S/M	-	7,5	100	50	572	350	490	450	1350	525	150	576	250	200	6xØ19 (M16)	450	1415	284	B80B
		200L	37	-	100	50	572	350	650	610	1550	575	200	576	328	200	6xØ19 (M16)	647	1697	528	B125A
		225S/M	45	-	100	50	572	350	660	610	1600	600	200	576	368	200	6xØ19 (M16)	752	1786	684	B125A
		250S/M	55	-	100	50	572	350	720	670	1700	650	200	576	393	200	6xØ19 (M16)	791	1895	781	B140A
	9	132S/M	-	5,5	100	50	572	350	490	450	1350	525	150	576	250	200	6xØ19 (M16)	450	1415	284	B80B
		132S/M	-	7,5	100	50	572	350	490	450	1350	525	150	576	250	200	6xØ19 (M16)	450	1415	284	B80B
		225S/M	45	-	100	50	634	350	660	610	1700	650	200	700	368	200	6xØ19 (M16)	752	1910	698	B125A
		250S/M	55	-	100	50	634	350	720	670	1800	700	200	700	393	200	6xØ19 (M16)	791	2019	794	B140A
		280S/M	75	-	100	50	634	350	820	770	1900	750	200	700	448	200	6xØ19 (M16)	913	2125	1036	B160A
	10	132S/M	-	5,5	100	50	634	350	490	450	1450	575	150	700	250	200	6xØ19 (M16)	450	1539	298	B80B
		132S/M	-	7,5	100	50	634	350	490	450	1450	575	150	700	250	200	6xØ19 (M16)	450	1539	298	B80B
		225S/M	45	-	100	50	696	350	660	610	1700	650	200	700	368	200	6xØ19 (M16)	752	1910	710	B125A
		250S/M	55	-	100	50	696	350	720	670	1800	700	200	700	393	200	6xØ19 (M16)	791	2019	806	B140A
		280S/M	75	-	100	50	696	350	820	770	1900	750	200	700	448	200	6xØ19 (M16)	913	2125	1048	B160A
	11	132S/M	-	7,5	100	50	696	350	490	450	1450	575	150	700	250	200	6xØ19 (M16)	450	1539	310	B80B
		160M	-	11	100	50	696	350	490	450	1600	600	200	700	288	200	6xØ19 (M16)	528	1658	352	B95A
		250S/M	55	-	100	50	758	350	720	670	1900	750	200	824	393	200	6xØ19 (M16)	791	2143	820	B140A
		280S/M	75	-	100	50	758	350	820	770	2000	800	200	824	448	200	6xØ19 (M16)	913	2249	1093	B160A
		132S/M	-	7,5	100	50	758	350	490	450	1600	650	150	824	250	200	6xØ19 (M16)	450	1663	325	B80B
	12	160M	-	11	100	50	758	350	490	450	1700	650	200	824	288	200	6xØ19 (M16)	528	1782	365	B95A
		280S/M	75	-	100	50	820	350	820	770	2000	800	200	824	448	200	6xØ19 (M16)	913	2249	1105	B160A
		280S/M	90	-	100	50	820	350	820	770	2000	800	200	824	448	200	6xØ19 (M16)	913	2249	1135	B160A
		132S/M	-	7,5	100	50	820	350	490	450	1600	650	150	824	250	200	6xØ19 (M16)	450	1663	337	B80B
		160M	-	11	100	50	820	350	490	450	1700	650	200	824	288	200	6xØ19 (M16)	528	1782	377	B95A
	13	280S/M	75	-	100	50	882	350	820	770	2150	875	200	948	448	200	6xØ19 (M16)	913	2373	1123	B160A
		280S/M	90	-	100	50	882	350	820	770	2150	875	200	948	448	200	6xØ19 (M16)	913	2373	1153	B160A
		132S/M	-	7,5	100	50	882	350	490	450	1700	700	150	948	250	200	6xØ19 (M16)	450	1787	350	B80B
		160M	-	11	100	50	882	350	490	450	1850	725	200	948	288	200	6xØ19 (M16)	528	1906	393	B95A
		280S/M	75	-	100	50	944	350	820	770	2150	875	200	948	448	200	6xØ19 (M16)	913	2373	1135	B160A
	14	280S/M	90	-	100	50	944	350	820	770	2150	875	200	948	448	200	6xØ19 (M16)	913	2373	1165	B160A
		160M	-	11	100	50	944	350	490	450	1850	725	200	948	288	200	6xØ19 (M16)	528	1906	405	B95A
		160L	-	15	100	50	944	350	490	450	1850	725	200	948	288	200	6xØ19 (M16)	528	1906	450	B110A
		280S/M	75	-	100	50	1006	350	820	770	2250	925	200	1072	448	200	6xØ19 (M16)	913	2497	1149	B160A
		315S/M	110	-	100	50	1006	350	860	810	2350	925	250	1072	503	200	6xØ26 (M20)	1033	2670	1425	B160A
	15	160M	-	11	100	50	1006	350	490	450	1950	775	200	1072	288	200	6xØ19 (M16)	528	2030	418	B95A
		160L	-	15	100	50	1006	350	490	450	1950	775	200	1072	288	200	6xØ19 (M16)	528	2030	463	B110A
		160M	-	11	100	50	1068	350	490	450	1950	775	200	1072	288	200	6xØ19 (M16)	528	2030	430	B95A
		160L	-	15	100	50	1068	350	490	450	1950	775	200	1072	288	200	6xØ19 (M16)	528	2030	475	B110A
		160M	-	11	100	50	1130	350	490	450	2050										

MPA SERIES - Size 65
DIMENSIONS AND WEIGHTS AT 50 Hz

PUMP TYPE	NUMBER OF STAGES	IEC MOTOR FRAME	3000 [rpm]	1500 [rpm]	DIMENSIONS [mm]															WEIGHT	COUPLING TYPE	
					DNS	DND	a1	f	B1	B2	L1	L2	L3	L4	H	h2	s	Hmax	Lmax			G [kg]
MPA Size 65	2	160L	18,5	-	125	65	248	393	560	520	1150	375	200	253	313	225	6xØ19 (M16)	553	1254	328	B95D	
		180M	22	-	125	65	248	393	560	520	1200	400	200	253	313	225	6xØ19 (M16)	594	1314	391	B110D	
		200L	30	-	125	65	248	393	650	610	1250	425	200	253	323	225	6xØ19 (M16)	642	1417	472	B125B	
		200L	37	-	125	65	248	393	650	610	1250	425	200	253	323	225	6xØ19 (M16)	642	1417	487	B125B	
		112M	-	4	125	65	248	393	550	510	950	325	150	253	293	225	6xØ19 (M16)	518	1092	261	B95B	
			132S/M	-	5,5	125	65	248	393	550	510	1100	400	150	331	293	225	6xØ19 (M16)	518	1213	269	B95C
		3	200L	37	-	125	65	326	393	650	610	1400	500	200	409	323	225	6xØ19 (M16)	642	1573	518	B125B
			225S/M	45	-	125	65	326	393	660	610	1450	525	200	409	373	225	6xØ19 (M16)	757	1662	669	B125B
			250S/M	55	-	125	65	326	393	720	670	1550	575	200	409	393	225	6xØ19 (M16)	791	1771	762	B140B
			132S/M	-	5,5	125	65	326	393	550	510	1100	400	150	331	293	225	6xØ19 (M16)	518	1213	293	B95C
			132S/M	-	7,5	125	65	326	393	550	510	1100	400	150	331	293	225	6xØ19 (M16)	518	1213	293	B95C
		4	225S/M	45	-	125	65	404	393	660	610	1450	525	200	409	373	225	6xØ19 (M16)	757	1662	693	B125B
			250S/M	55	-	125	65	404	393	720	670	1550	575	200	409	393	225	6xØ19 (M16)	791	1771	786	B140B
			280S/M	75	-	125	65	404	393	820	770	1700	650	200	487	443	225	6xØ26 (M20)	908	1955	1055	B160B
			132S/M	-	7,5	125	65	404	393	550	510	1300	500	150	487	293	225	6xØ19 (M16)	518	1369	323	B95C
	160M		-	11	125	65	404	393	560	520	1350	475	200	409	313	225	6xØ19 (M16)	553	1410	359	B95D	
	5	280S/M	75	-	125	65	482	393	820	770	1700	650	200	487	443	225	6xØ26 (M20)	908	1955	1079	B160B	
		280S/M	90	-	125	65	482	393	820	770	1700	650	200	487	443	225	6xØ26 (M20)	908	1955	1109	B160B	
		315S/M	110	-	125	65	482	393	860	810	1950	775	200	487	513	225	6xØ26 (M20)	1043	2128	1401	B160B	
		160M	-	11	125	65	482	393	560	520	1500	550	200	565	313	225	6xØ19 (M16)	553	1566	386	B95D	
		160L	-	15	125	65	482	393	560	520	1500	550	200	565	313	225	6xØ19 (M16)	553	1566	431	B110C	
	6	280S/M	75	-	125	65	560	393	820	770	1850	725	200	643	443	225	6xØ26 (M20)	908	2111	1108	B160B	
		280S/M	90	-	125	65	560	393	820	770	1850	725	200	643	443	225	6xØ26 (M20)	908	2111	1138	B160B	
		315S/M	110	-	125	65	560	393	860	810	2100	850	200	643	513	225	6xØ26 (M20)	1043	2284	1431	B160B	
		160M	-	11	125	65	560	393	560	520	1500	550	200	565	313	225	6xØ19 (M16)	553	1566	410	B95D	
		160L	-	15	125	65	560	393	560	520	1500	550	200	565	313	225	6xØ19 (M16)	553	1566	455	B110C	
	7	280S/M	90	-	125	65	638	393	820	770	1850	725	200	643	443	225	6xØ26 (M20)	908	2111	1162	B160B	
		315S/M	132	-	125	65	638	393	860	810	2100	850	200	643	513	225	6xØ26 (M20)	1043	2284	1505	B160B	
		160M	-	11	125	65	638	393	560	520	1650	625	200	721	313	225	6xØ19 (M16)	553	1722	437	B95D	
		180M	-	18,5	125	65	638	393	560	520	1600	600	200	643	313	225	6xØ19 (M16)	594	1704	522	B110D	
	8	315S/M	110	-	125	65	716	393	860	810	2250	925	200	799	513	225	6xØ26 (M20)	1043	2440	1484	B160B	
		315S/M	160	-	125	65	716	393	860	810	2250	925	200	799	513	225	6xØ26 (M20)	1043	2440	1664	B160B	
		160L	-	15	125	65	716	393	560	520	1650	625	200	721	313	225	6xØ19 (M16)	553	1722	506	B110C	
		180M	-	18,5	125	65	716	393	560	520	1750	675	200	799	313	225	6xØ19 (M16)	594	1860	549	B110D	
	9	315S/M	110	-	125	65	794	393	860	810	2250	925	200	799	513	225	6xØ26 (M20)	1043	2440	1508	B160B	
		315S/M	132	-	125	65	794	393	860	810	2250	925	200	799	513	225	6xØ26 (M20)	1043	2440	1558	B160B	
		315S/M	160	-	125	65	794	393	860	810	2250	925	200	799	513	225	6xØ26 (M20)	1043	2440	1688	B160B	
		315L	200	-	125	65	794	393	860	810	2250	925	200	799	513	225	6xØ26 (M20)	1088	2549	1813	B180B	
		160L	-	15	125	65	794	393	560	520	1800	700	200	877	313	225	6xØ19 (M16)	553	1878	533	B110C	
		180L	-	22	125	65	794	393	560	520	1750	675	200	799	313	225	6xØ19 (M16)	594	1898	590	B110D	
	10	315S/M	132	-	125	65	872	393	860	810	2400	950	250	955	513	225	6xØ26 (M20)	1043	2596	1587	B160B	
		315L	200	-	125	65	872	393	860	810	2400	950	250	955	513	225	6xØ26 (M20)	1088	2705	1842	B180B	
		180M	-	18,5	125	65	872	393	560	520	1900	750	200	955	313	225	6xØ19 (M16)	594	2016	600	B110D	
		200L	-	30	125	65	872	393	650	610	1950	775	200	955	323	225	6xØ19 (M16)	642	2119	677	B125B	
	11	180M	-	18,5	125	65	950	393	560	520	1900	750	200	955	313	225	6xØ19 (M16)	594	2016	624	B110D	
		200L	-	30	125	65	950	393	650	610	1950	775	200	955	323	225	6xØ19 (M16)	642	2119	701	B125B	
	12	180L	-	22	125	65	1028	393	560	520	2050	825	200	1111	313	225	6xØ19 (M16)	594	2210	668	B110D	
		200L	-	30	125	65	1028	393	650	610	2100	850	200	1111	323	225	6xØ19 (M16)	642	2275	728	B125B	
	13	180L	-	22	125	65	1106	393	560	520	2050	825	200	1111	313	225	6xØ19 (M16)	594	2210	692	B110D	
		200L	-	30	125	65	1106	393	650	610	2100	850	200	1111	323	225	6xØ19 (M16)	642	2275	752	B125B	
	14	200L	-	30	125	65	1184	393	650	610	2300	900	250	1267	323	225	6xØ19 (M16)	642	2431	782	B125B	
		225S/M	-	37	125	65	1184	393	660	610	2350	925	250	1267	373	225	6xØ19 (M16)	757	2550	946	B140B	
	15	200L	-	30	125	65	1262	393	650	610	2300	900	250	1267	323	225	6xØ19 (M16)	642	2431	806	B125B	
		225S/M	-	37	125	65	1262	393	660	610	2350	925	250	1267	373	225	6xØ19 (M16)	757	2550	970	B140B	

NOTE. Pumps supplied with flanges according to EN 1092-2 as standard; available ASME B16.5 version on request.
For flanges dimensions see drawing on pages 90-91.

e-MPA-AS-65-en_a_1d

MPA SERIES - Size 100 DIMENSIONS AND WEIGHTS AT 50 Hz

PUMP TYPE MPA Size	NUMBER OF STAGES	IEC MOTOR FRAME	3000 [rpm]		1500 [rpm]		DIMENSIONS [mm]														WEIGHT G [kg]	COUPLING TYPE
			[kW]	[kW]	DNS	DND	a1	f	B1	B2	L1	L2	L3	L4	H	h2	s	Hmax	Lmax			
100	2	225S/M	45	-	150	100	290	472	720	670	1450	525	200	307	378	275	6xØ19 (M16)	762	1639	750	B125C	
		250S/M	55	-	150	100	290	472	720	670	1550	575	200	307	398	275	6xØ19 (M16)	796	1748	840	B140C	
		280S/M	75	-	150	100	290	472	820	770	1600	600	200	307	443	275	6xØ26 (M20)	908	1854	1088	B160C	
		280S/M	90	-	150	100	290	472	820	770	1600	600	200	307	443	275	6xØ26 (M20)	908	1854	1118	B160C	
		315S/M	110	-	150	100	290	472	860	810	1900	750	200	397	503	275	6xØ26 (M20)	1033	2117	1406	B160C	
		132S/M	-	5,5	150	100	290	472	710	670	1200	400	200	307	358	275	6xØ19 (M16)	633	1268	406	B110E	
		132S/M	-	7,5	150	100	290	472	710	670	1200	400	200	307	358	275	6xØ19 (M16)	633	1268	406	B110E	
	160M	-	11	150	100	290	472	710	670	1350	475	200	307	363	275	6xØ19 (M16)	638	1387	433	B110F		
	3	280S/M	90	-	150	100	380	472	820	770	1800	700	200	487	443	275	6xØ26 (M20)	908	2034	1172	B160C	
		315S/M	110	-	150	100	380	472	860	810	1900	750	200	397	503	275	6xØ26 (M20)	1033	2117	1444	B160C	
		315S/M	132	-	150	100	380	472	860	810	1900	750	200	397	503	275	6xØ26 (M20)	1033	2117	1494	B160C	
		315S/M	160	-	150	100	380	472	860	810	1900	750	200	397	503	275	6xØ26 (M20)	1033	2117	1624	B160C	
		160M	-	11	150	100	380	472	710	670	1550	575	200	487	363	275	6xØ19 (M16)	638	1567	484	B110F	
		160L	-	15	150	100	380	472	710	670	1550	575	200	487	363	275	6xØ19 (M16)	638	1567	528	B110F	
		180M	-	18,5	150	100	380	472	710	670	1450	525	200	397	363	275	6xØ19 (M16)	644	1537	568	B110G	
	4	315S/M	132	-	150	100	470	472	860	810	2100	850	200	577	503	275	6xØ26 (M20)	1033	2297	1578	B160C	
		315S/M	160	-	150	100	470	472	860	810	2100	850	200	577	503	275	6xØ26 (M20)	1033	2297	1708	B160C	
		315L	200	-	150	100	470	472	860	810	2100	850	200	577	503	275	6xØ26 (M20)	1078	2406	1832	B180D	
		160L	-	15	150	100	470	472	710	670	1550	575	200	487	363	275	6xØ19 (M16)	638	1567	566	B110F	
		180M	-	18,5	150	100	470	472	710	670	1650	625	200	577	363	275	6xØ19 (M16)	644	1717	613	B110G	
		180L	-	22	150	100	470	472	710	670	1650	625	200	577	363	275	6xØ19 (M16)	644	1755	630	B110G	
	5	315S/M	160	-	150	100	560	472	860	810	2100	850	200	577	503	275	6xØ26 (M20)	1033	2297	1746	B160C	
		315L	200	-	150	100	560	472	860	810	2100	850	200	577	503	275	6xØ26 (M20)	1078	2406	1870	B180D	
		315L	250	-	150	100	560	472	860	810	2100	850	200	577	503	275	6xØ26 (M20)	1078	2406	2020	B180D	
		180L	-	22	150	100	560	472	710	670	1650	625	200	577	363	275	6xØ19 (M16)	644	1755	668	B110G	
		200L	-	30	150	100	560	472	710	670	1800	700	200	667	363	275	6xØ19 (M16)	682	1910	722	B125C	
	6	315L	200	-	150	100	650	472	860	810	2300	900	250	757	503	275	6xØ26 (M20)	1078	2586	1917	B180D	
		315L	250	-	150	100	650	472	860	810	2300	900	250	757	503	275	6xØ26 (M20)	1078	2586	2067	B180D	
		355M/L	315	-	150	100	650	472	1000	930	2400	950	250	757	583	275	6xØ29 (M24)	1203	2645	2785	B200B	
		200L	-	30	150	100	650	472	710	670	1800	700	200	667	363	275	6xØ19 (M16)	682	1910	760	B125C	
		225S/M	-	37	150	100	650	472	720	670	1950	775	200	757	378	275	6xØ19 (M16)	762	2119	920	B140C	
	7	315L	250	-	150	100	740	472	860	810	2300	900	250	757	503	275	6xØ26 (M20)	1078	2586	2105	B180D	
		355M/L	315	-	150	100	740	472	1000	930	2400	950	250	757	583	275	6xØ29 (M24)	1203	2645	2823	B200B	
		355M/L	355	-	150	100	740	472	1000	930	2400	950	250	757	583	275	6xØ29 (M24)	1203	2645	2823	B200B	
		200L	-	30	150	100	740	472	720	670	2050	825	200	937	383	275	6xØ19 (M16)	702	2180	825	B125C	
		225S/M	-	37	150	100	740	472	720	670	1950	775	200	757	378	275	6xØ19 (M16)	762	2119	958	B140C	
		225S/M	-	45	150	100	740	472	720	670	1950	775	200	757	378	275	6xØ19 (M16)	762	2119	993	B140C	
	8	225S/M	-	37	150	100	830	472	720	670	2150	875	200	937	398	275	6xØ26 (M20)	782	2299	1023	B140C	
		225S/M	-	45	150	100	830	472	720	670	2150	875	200	937	398	275	6xØ26 (M20)	782	2299	1058	B140C	
	9	225S/M	-	45	150	100	920	472	720	670	2150	875	200	937	398	275	6xØ26 (M20)	782	2299	1096	B140C	
		250S/M	-	55	150	100	920	472	720	670	2200	900	200	937	418	275	6xØ26 (M20)	816	2378	1205	B160C	
	10	225S/M	-	45	150	100	1010	472	720	670	2300	900	250	1117	398	275	6xØ26 (M20)	782	2479	1138	B140C	
		250S/M	-	55	150	100	1010	472	720	670	2350	925	250	1117	418	275	6xØ26 (M20)	816	2558	1247	B160C	
	11	250S/M	-	55	150	100	1100	472	720	670	2350	925	250	1117	418	275	6xØ26 (M20)	816	2558	1285	B160C	
		280S/M	-	75	150	100	1100	472	820	770	2400	950	250	1117	443	275	6xØ26 (M20)	908	2664	1434	B180E	

NOTE. Pumps supplied with flanges according to EN 1092-2 as standard; available ASME B16.5 version on request.
For flanges dimensions see drawing on pages 90-91.

e-MPA-AS-100-en_a_td

MPA SERIES - Size 125 DIMENSIONS AND WEIGHTS AT 50 Hz

PUMP TYPE MPA Size	NUMBER OF STAGES	IEC MOTOR FRAME	3000 [rpm]	1500 [rpm]	DIMENSIONS [mm]															WEIGHT G [kg]	COUPLING TYPE
					DNS	DND	a1	f	B1	B2	L1	L2	L3	L4	H	h2	s	Hmax	Lmax		
125	2	315S/M	132	-	200	125	388	488	860	810	1950	775	200	390	508	325	6xØ26 (M20)	1038	2126	1631	B160D
		315S/M	160	-	200	125	388	488	860	810	1950	775	200	390	508	325	6xØ26 (M20)	1038	2126	1761	B160D
		315L	200	-	200	125	388	488	860	810	1950	775	200	390	508	325	6xØ26 (M20)	1083	2235	1885	B180F
		315L	250	-	200	125	388	488	860	810	1950	775	200	390	508	325	6xØ26 (M20)	1083	2235	2035	B180F
		355M/L	315	-	200	125	388	488	1000	930	2050	825	200	390	588	325	6xØ29 (M24)	1208	2294	2753	B200D
		160L	-	15	200	125	388	488	750	710	1400	500	200	390	428	325	6xØ19 (M16)	753	1486	698	B125D
		180M	-	18,5	200	125	388	488	750	710	1450	525	200	390	428	325	6xØ19 (M16)	753	1546	737	B125E
		180L	-	22	200	125	388	488	750	710	1450	525	200	390	428	325	6xØ19 (M16)	753	1584	754	B125E
		200L	-	30	200	125	388	488	750	710	1500	550	200	390	428	325	6xØ19 (M16)	753	1649	802	B125F
	225S/M	-	37	200	125	388	488	760	710	1550	575	200	390	448	325	6xØ19 (M16)	832	1768	954	B140D	
	3	315L	250	-	200	125	500	488	860	810	2050	825	200	502	508	325	6xØ26 (M20)	1083	2347	2111	B180F
		355M/L	315	-	200	125	500	488	1000	930	2200	900	200	502	588	325	6xØ29 (M24)	1208	2406	2836	B200D
		355M/L	355	-	200	125	500	488	1000	930	2200	900	200	502	588	325	6xØ29 (M24)	1208	2406	2836	B200D
		355A/B	400	-	200	125	500	488	1000	930	2300	900	250	502	588	325	6xØ29 (M24)	1313	2601	3152	B225C
		200L	-	30	200	125	500	488	750	710	1600	600	200	502	428	325	6xØ19 (M16)	753	1761	877	B125F
		225S/M	-	37	200	125	500	488	760	710	1650	625	200	502	448	325	6xØ19 (M16)	832	1880	1029	B140D
		225S/M	-	45	200	125	500	488	760	710	1650	625	200	502	448	325	6xØ19 (M16)	832	1880	1064	B140D
	250S/M	-	55	200	125	500	488	760	710	1750	675	200	502	448	325	6xØ19 (M16)	846	1959	1172	B160D	
	4	355M/L	315	-	200	125	612	488	1000	930	2300	900	250	614	588	325	6xØ29 (M24)	1208	2518	2939	B200D
		355M/L	355	-	200	125	612	488	1000	930	2300	900	250	614	588	325	6xØ29 (M24)	1208	2518	2939	B200D
		355A/B	400	-	200	125	612	488	1000	930	2400	950	250	614	588	325	6xØ29 (M24)	1313	2713	3254	B225C
		355A/B	450	-	200	125	612	488	1000	930	2400	950	250	614	588	325	6xØ29 (M24)	1313	2713	3404	B225C
		400J/H	500	-	200	125	612	488	1140	1070	2700	1050	300	614	692	325	6xØ29 (M24)	1067	3106	4384	B225D
		400J/H	560	-	200	125	612	488	1140	1070	2700	1050	300	614	692	325	6xØ29 (M24)	1067	3106	4384	B225D
		225S/M	-	45	200	125	612	488	760	710	1800	700	200	614	448	325	6xØ19 (M16)	832	1992	1142	B140D
		250S/M	-	55	200	125	612	488	760	710	1850	725	200	614	448	325	6xØ19 (M16)	846	2071	1246	B160D
		280S/M	-	75	200	125	612	488	820	770	1950	775	200	614	468	325	6xØ26 (M20)	933	2177	1404	B180G
	5	355A/B	400	-	200	125	724	488	1000	930	2550	1025	250	726	588	325	6xØ29 (M24)	1313	2825	3332	B225C
		355A/B	450	-	200	125	724	488	1000	930	2550	1025	250	726	588	325	6xØ29 (M24)	1313	2825	3482	B225C
		400J/H	500	-	200	125	724	488	1140	1070	2850	1125	300	726	692	325	6xØ29 (M24)	1067	3218	4465	B225D
		400J/H	560	-	200	125	724	488	1140	1070	2850	1125	300	726	692	325	6xØ29 (M24)	1067	3218	4465	B225D
		400J/H	630	-	200	125	724	488	1140	1070	2850	1125	300	726	692	325	6xØ29 (M24)	1067	3218	4557	RWS252B
		280S/M	-	75	200	125	724	488	820	770	2050	825	200	726	468	325	6xØ26 (M20)	933	2289	1474	B180G
		280S/M	-	90	200	125	724	488	820	770	2050	825	200	726	468	325	6xØ26 (M20)	933	2289	1544	B180G
	6	280S/M	-	75	200	125	836	488	820	770	2150	875	200	838	468	325	6xØ26 (M20)	933	2401	1543	B180G
		315S/M	-	110	200	125	836	488	860	810	2400	950	250	838	508	325	6xØ26 (M20)	1038	2604	1944	B200E
	7	280S/M	-	90	200	125	948	488	820	770	2250	925	200	950	468	325	6xØ26 (M20)	933	2513	1683	B180G
		315S/M	-	110	200	125	948	488	860	810	2500	1000	250	950	508	325	6xØ26 (M20)	1038	2716	2014	B200E
	8	315S/M	-	110	200	125	1060	488	860	810	2650	1075	250	1062	508	325	6xØ26 (M20)	1038	2828	2089	B200E

NOTE. Pumps supplied with flanges according to EN 1092-2 as standard; available ASME B16.5 version on request.
For flanges dimensions see drawing on pages 90-91.

e-MPA-AS-125-en_a_ld

MPR SERIES DIMENSIONS AND WEIGHTS AT 50 Hz

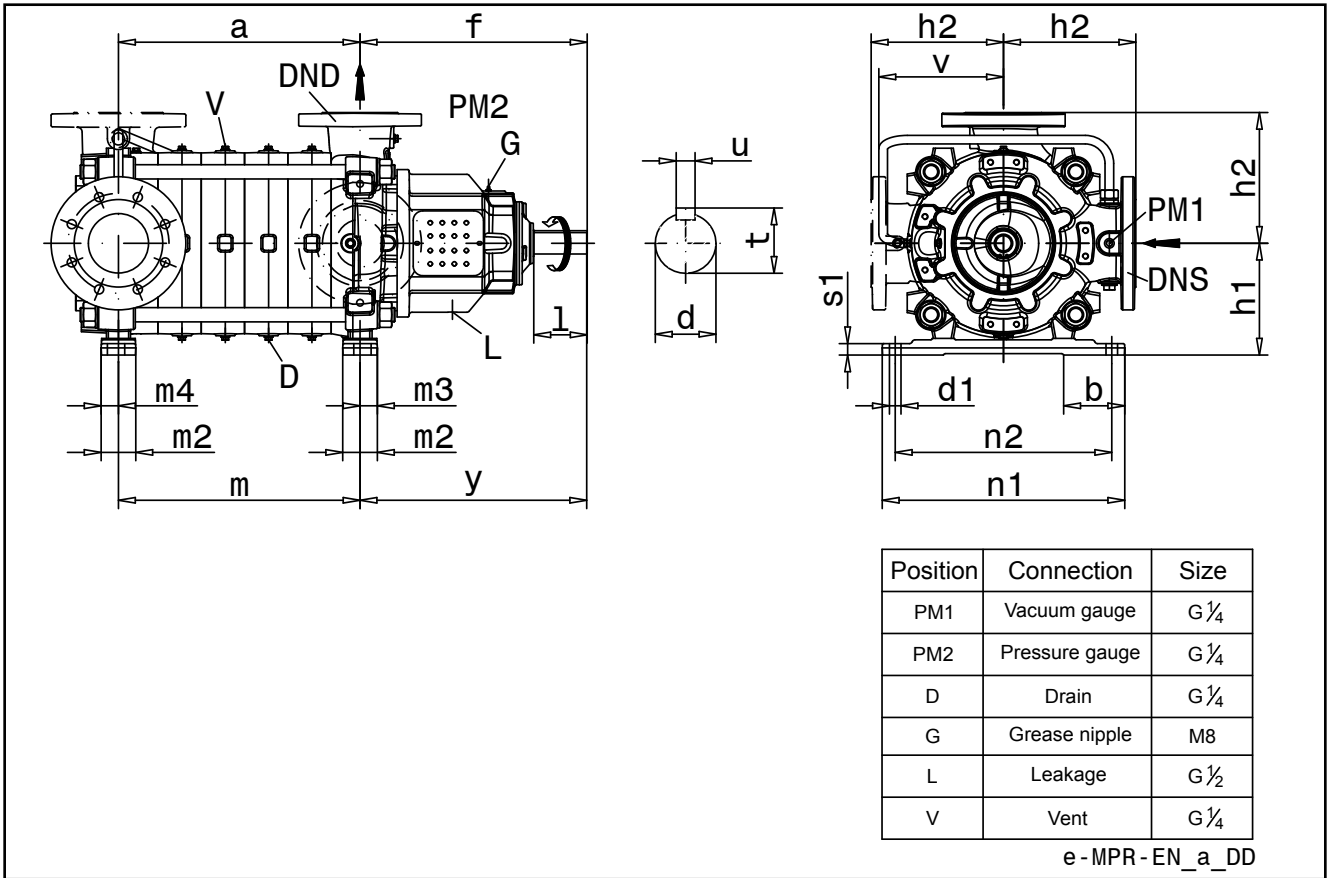

PUMP TYPE	DIMENSIONS [mm]																		
	MPR	Pump dimensions						Feet dimensions						Shaft end					
		Size	DNS	DND	f	h1	h2	v	y	m2	m3	m4	n1	n2	b	d1	s1	d	t
50	80	50	350	150	200	200	350	54	24	27	332	290	90	14	21	28j6	31	8	70
65	100	65	393	190	225	225	393	60	30	30	410	365	99	19	20	35k6	38	10	80
100	125	100	472	235	275	275	472	72	36	36	504	450	125	24	24	45k6	48,5	14	110
125	150	125	488	300	325	325	488	90	45	45	610	560	209	26	50	52k6	56	16	110
150	200	150	580	350	400	400	580	100	40	40	735	680	260	26	50	60m6	64	18	135

NOTE. Pumps supplied with flanges according to EN 1092-2 as standard; available ASME B16.5 version on request.
For flanges dimensions see drawing on pages 92-93.

e-MPR-en_b_td

SIZE	50			65			100			125			150		
	NUMBER OF STAGES	a	m	G [kg]	a	m	G [kg]	a	m	G [kg]	a	m	G [kg]	a	m
1	87	87	84	110	110	125	142	142	226	173	173	383	210	230	-
2	149	149	96	188	188	149	232	232	264	285	285	450	342	362	-
3	211	211	108	266	266	173	322	322	302	397	397	517	474	494	-
4	273	273	120	344	344	197	412	412	340	509	509	584	606	626	-
5	335	335	132	422	422	221	502	502	378	621	621	651	738	758	-
6	397	397	144	500	500	245	592	592	416	733	733	718	870	890	-
7	459	459	156	578	578	269	682	682	454	845	845	785			
8	521	521	168	656	656	293	772	772	492	957	957	852			
9	583	583	180	734	734	317	862	862	530						
10	645	645	192	812	812	341	952	952	568						
11	707	707	204	890	890	365	1042	1042	606						
12	769	769	216	968	968	389									
13	831	831	228	1046	1046	413									
14	893	893	240	1124	1124	437									
15	955	955	252	1202	1202	461									
16	1017	1017	264												
17	1079	1079	276												
18	1141	1141	288												

e-MPR-stage-en_b_td

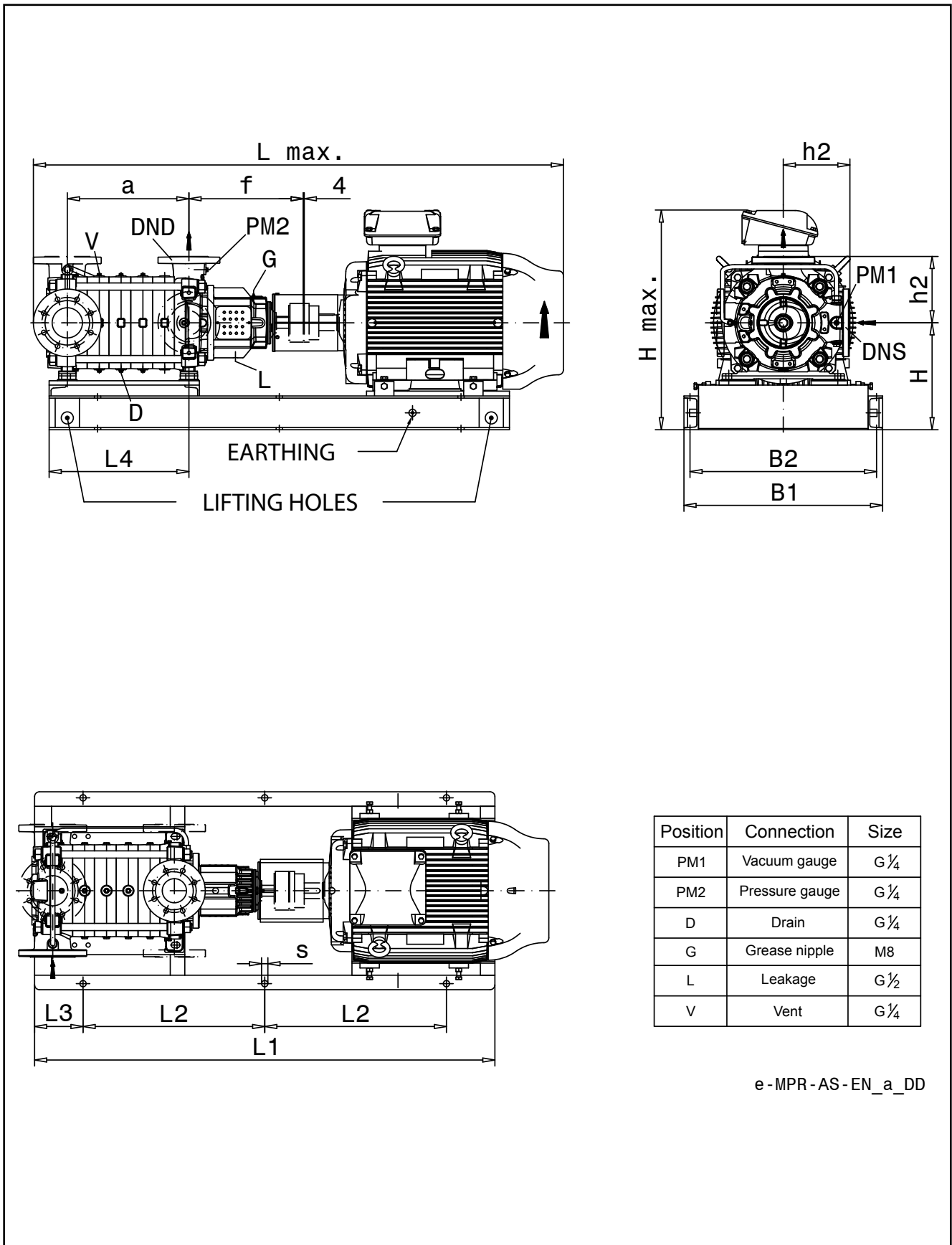
**MPR SERIES
DIMENSIONS AND WEIGHTS AT 50 Hz**

MPR SERIES - Size 50

DIMENSIONS AND WEIGHTS AT 50 Hz

PUMP TYPE MPR Size	NUMBER OF STAGES	IEC MOTOR FRAME	3000 [rpm]	1500 [rpm]	DIMENSIONS [mm]														WEIGHT G [kg]	COUPLING TYPE	
					DNS	DND	a	f	B1	B2	L1	L2	L3	L4	H	h2	s	Hmax			Lmax
50	1	132S/M	5,5	-	80	50	87	350	490	450	950	325	150	204	250	200	6xØ19 (M16)	450	1005	190	B80B
		132S/M	7,5	-	80	50	87	350	490	450	950	325	150	204	250	200	6xØ19 (M16)	450	1005	186	B80B
		100L	-	2,2	80	50	87	350	484	450	850	275	150	204	233	200	6xØ15 (M12)	433	1000	162	B80A
	2	132S/M	5,5	-	80	50	149	350	490	450	950	325	150	204	250	200	6xØ19 (M16)	450	1055	202	B80B
		132S/M	7,5	-	80	50	149	350	490	450	950	325	150	204	250	200	6xØ19 (M16)	450	1055	198	B80B
		160M	11	-	80	50	149	350	490	450	1100	350	200	204	288	200	6xØ19 (M16)	528	1212	266	B95A
		160M	15	-	80	50	149	350	490	450	1100	350	200	204	288	200	6xØ19 (M16)	528	1212	267	B95A
		100L	-	2,2	80	50	149	350	484	450	850	275	150	204	233	200	6xØ15 (M12)	433	1050	174	B80A
	3	160M	11	-	80	50	211	350	490	450	1200	400	200	328	288	200	6xØ19 (M16)	528	1286	282	B95A
		160M	15	-	80	50	211	350	490	450	1200	400	200	328	288	200	6xØ19 (M16)	528	1286	283	B95A
		160L	18,5	-	80	50	211	350	490	450	1200	400	200	328	288	200	6xØ19 (M16)	528	1286	290	B95A
		180M	22	-	80	50	211	350	490	450	1200	400	200	266	308	200	6xØ19 (M16)	589	1334	353	B110B
		100L	-	2,2	80	50	211	350	484	450	1000	350	150	328	233	200	6xØ15 (M12)	433	1124	191	B80A
	4	160M	15	-	80	50	273	350	490	450	1200	400	200	328	288	200	6xØ19 (M16)	528	1336	295	B95A
		160L	18,5	-	80	50	273	350	490	450	1200	400	200	328	288	200	6xØ19 (M16)	528	1336	302	B95A
		180M	22	-	80	50	273	350	490	450	1300	450	200	390	308	200	6xØ19 (M16)	589	1408	370	B110B
		200L	30	-	80	50	273	350	650	610	1300	450	200	328	328	200	6xØ19 (M16)	647	1499	459	B125A
		100L	-	3	80	50	273	350	484	450	1000	350	150	328	233	200	6xØ15 (M12)	433	1174	207	B80A
	5	112M	-	4	80	50	273	350	484	450	1050	375	150	390	233	200	6xØ15 (M12)	433	1186	225	B80A
		180M	22	-	80	50	335	350	490	450	1300	450	200	390	308	200	6xØ19 (M16)	589	1458	382	B110B
		200L	30	-	80	50	335	350	650	610	1450	525	200	452	328	200	6xØ19 (M16)	647	1573	483	B125A
		200L	37	-	80	50	335	350	650	610	1450	525	200	452	328	200	6xØ19 (M16)	647	1573	498	B125A
		100L	-	3	80	50	335	350	484	450	1100	400	150	452	233	200	6xØ15 (M12)	433	1248	220	B80A
	6	112M	-	4	80	50	335	350	484	450	1050	375	150	390	233	200	6xØ15 (M12)	433	1236	237	B80A
		200L	30	-	80	50	397	350	650	610	1450	525	200	452	328	200	6xØ19 (M16)	647	1623	495	B125A
		200L	37	-	80	50	397	350	650	610	1450	525	200	452	328	200	6xØ19 (M16)	647	1623	510	B125A
		132S/M	-	5,5	80	50	397	350	490	450	1200	450	150	514	233	200	6xØ15 (M12)	433	1310	252	B80A
	7	112M	-	4	80	50	397	350	484	450	1200	450	150	514	233	200	6xØ15 (M12)	433	1310	252	B80A
		200L	30	-	80	50	459	350	650	610	1550	575	200	576	328	200	6xØ19 (M16)	647	1697	508	B125A
		200L	37	-	80	50	459	350	650	610	1550	575	200	576	328	200	6xØ19 (M16)	647	1697	523	B125A
		225S/M	45	-	80	50	459	350	660	610	1600	600	200	576	368	200	6xØ19 (M16)	752	1786	679	B125A
		112M	-	4	80	50	459	350	484	450	1200	450	150	514	233	200	6xØ15 (M12)	433	1360	264	B80A
	8	132S/M	-	5,5	80	50	459	350	490	450	1350	525	150	576	250	200	6xØ19 (M16)	450	1415	279	B80B
		200L	37	-	80	50	521	350	650	610	1550	575	200	576	328	200	6xØ19 (M16)	647	1747	535	B125A
		225S/M	45	-	80	50	521	350	660	610	1600	600	200	576	368	200	6xØ19 (M16)	752	1836	691	B125A
		250S/M	55	-	80	50	521	350	720	670	1700	650	200	576	393	200	6xØ19 (M16)	791	1945	788	B140A
		132S/M	-	7,5	80	50	521	350	490	450	1350	525	150	576	250	200	6xØ19 (M16)	450	1465	291	B80B
	9	132S/M	-	7,5	80	50	521	350	490	450	1350	525	150	576	250	200	6xØ19 (M16)	450	1465	291	B80B
		225S/M	45	-	80	50	583	350	660	610	1700	650	200	700	368	200	6xØ19 (M16)	752	1910	705	B125A
		250S/M	55	-	80	50	583	350	720	670	1800	700	200	700	393	200	6xØ19 (M16)	791	2019	801	B140A
		280S/M	75	-	80	50	583	350	820	770	1900	750	200	700	448	200	6xØ19 (M16)	913	2125	1043	B160A
		132S/M	-	5,5	80	50	583	350	490	450	1450	575	150	700	250	200	6xØ19 (M16)	450	1539	305	B80B
	10	132S/M	-	7,5	80	50	583	350	490	450	1450	575	150	700	250	200	6xØ19 (M16)	450	1539	305	B80B
		225S/M	45	-	80	50	645	350	660	610	1700	650	200	700	368	200	6xØ19 (M16)	752	1960	717	B125A
		250S/M	55	-	80	50	645	350	720	670	1800	700	200	700	393	200	6xØ19 (M16)	791	2069	813	B140A
		280S/M	75	-	80	50	645	350	820	770	1900	750	200	700	448	200	6xØ19 (M16)	913	2175	1055	B160A
		132S/M	-	7,5	80	50	645	350	490	450	1450	575	150	700	250	200	6xØ19 (M16)	450	1589	317	B80B
	11	160M	-	11	80	50	645	350	490	450	1600	600	200	700	288	200	6xØ19 (M16)	528	1708	359	B95A
		250S/M	55	-	80	50	707	350	720	670	1900	750	200	824	393	200	6xØ19 (M16)	791	2143	827	B140A
		280S/M	75	-	80	50	707	350	820	770	2000	800	200	824	448	200	6xØ19 (M16)	913	2249	1100	B160A
		132S/M	-	7,5	80	50	707	350	490	450	1600	650	150	824	250	200	6xØ19 (M16)	450	1663	332	B80B
		160M	-	11	80	50	707	350	490	450	1700	650	200	824	288	200	6xØ19 (M16)	528	1782	372	B95A
	12	280S/M	90	-	80	50	769	350	820	770	2000	800	200	824	448	200	6xØ19 (M16)	913	2299	1112	B160A
		280S/M	90	-	80	50	769	350	820	770	2000	800	200	824	448	200	6xØ19 (M16)	913	2299	1142	B160A
		132S/M	-	7,5	80	50	769	350	490	450	1600	650	150	824	250	200	6xØ19 (M16)	450	1713	344	B80B
		160M	-	11	80	50	769	350	490	450	1700	650	200	824	288	200	6xØ19 (M16)	528	1832	384	B95A
		280S/M	75	-	80	50	831	350	820	770	2150	875	200	948	448	200	6xØ19 (M16)	913	2373	1130	B160A
	13	280S/M	90	-	80	50	831	350	820	770	2150	875	200	948	448	200	6xØ19 (M16)	913	2373	1160	B160A
		132S/M	-	7,5	80	50	831	350	490	450	1700	700	150	948	250	200	6xØ19 (M16)	450	1787	357	B80B
		160M	-	11	80	50	831	350	490	450	1850	725	200	948	288	200	6xØ19 (M16)	528	1906	400	B95A
		280S/M	75	-	80	50	893	350	820	770	2150	875	200	948	448	200	6xØ19 (M16)	913	2423	1142	B160A
		280S/M	90	-	80	50	893	350	820	770	2150	875	200	948	448	200	6xØ19 (M16)	9			

MPR SERIES - Size 65
DIMENSIONS AND WEIGHTS AT 50 Hz

PUMP TYPE MPR Size	NUMBER OF STAGES	IEC MOTOR FRAME	3000 [rpm]	1500 [rpm]	DIMENSIONS [mm]														WEIGHT G [kg]	COUPLING TYPE	
					DNS	DND	a	f	B1	B2	L1	L2	L3	L4	H	h2	s	Hmax			Lmax
65	1	160M	15	-	100	65	110	393	560	520	1150	375	200	253	313	225	6xØ19 (M16)	553	1254	305	B95D
		160L	18,5	-	100	65	110	393	560	520	1150	375	200	253	313	225	6xØ19 (M16)	553	1254	312	B95D
		100L	-	2,2	100	65	110	393	550	510	950	325	150	253	293	225	6xØ19 (M16)	518	1092	225	B95B
	2	160L	18,5	-	100	65	188	393	560	520	1150	375	200	253	313	225	6xØ19 (M16)	553	1317	336	B95D
		180M	22	-	100	65	188	393	560	520	1200	400	200	253	313	225	6xØ19 (M16)	594	1377	399	B110D
		200L	30	-	100	65	188	393	650	610	1250	425	200	253	323	225	6xØ19 (M16)	642	1480	480	B125B
		200L	37	-	100	65	188	393	650	610	1250	425	200	253	323	225	6xØ19 (M16)	642	1480	495	B125B
		112M	-	4	100	65	188	393	550	510	950	325	150	253	293	225	6xØ19 (M16)	518	1155	269	B95B
		132S/M	-	5,5	100	65	188	393	550	510	1100	400	150	331	293	225	6xØ19 (M16)	518	1213	277	B95C
	3	200L	37	-	100	65	266	393	650	610	1400	500	200	409	323	225	6xØ19 (M16)	642	1573	526	B125B
		225S/M	45	-	100	65	266	393	660	610	1450	525	200	409	373	225	6xØ19 (M16)	757	1662	677	B125B
		250S/M	55	-	100	65	266	393	720	670	1550	575	200	409	393	225	6xØ19 (M16)	791	1771	770	B140B
		132S/M	-	5,5	100	65	266	393	550	510	1100	400	150	331	293	225	6xØ19 (M16)	518	1276	301	B95C
	4	132S/M	-	7,5	100	65	266	393	550	510	1100	400	150	331	293	225	6xØ19 (M16)	518	1276	301	B95C
		225S/M	45	-	100	65	344	393	660	610	1450	525	200	409	373	225	6xØ19 (M16)	757	1725	701	B125B
		250S/M	55	-	100	65	344	393	720	670	1550	575	200	409	393	225	6xØ19 (M16)	791	1834	794	B140B
		280S/M	75	-	100	65	344	393	820	770	1700	650	200	487	443	225	6xØ26 (M20)	908	1955	1063	B160B
	5	132S/M	-	7,5	100	65	344	393	550	510	1300	500	150	487	293	225	6xØ19 (M16)	518	1369	331	B95C
		160M	-	11	100	65	344	393	560	520	1350	475	200	409	313	225	6xØ19 (M16)	553	1473	367	B95D
		280S/M	75	-	100	65	422	393	820	770	1700	650	200	487	443	225	6xØ26 (M20)	908	2018	1087	B160B
		280S/M	90	-	100	65	422	393	820	770	1700	650	200	487	443	225	6xØ26 (M20)	908	2018	1117	B160B
		315S/M	110	-	100	65	422	393	860	810	1950	775	200	487	513	225	6xØ26 (M20)	1043	2191	1409	B160B
	6	160M	-	11	100	65	422	393	560	520	1500	550	200	565	313	225	6xØ19 (M16)	553	1566	394	B95D
		160L	-	15	100	65	422	393	560	520	1500	550	200	565	313	225	6xØ19 (M16)	553	1566	439	B110C
		280S/M	75	-	100	65	500	393	820	770	1850	725	200	643	443	225	6xØ26 (M20)	908	2111	1116	B160B
		280S/M	90	-	100	65	500	393	820	770	1850	725	200	643	443	225	6xØ26 (M20)	908	2111	1146	B160B
		315S/M	110	-	100	65	500	393	860	810	2100	850	200	643	513	225	6xØ26 (M20)	1043	2284	1439	B160B
	7	160M	-	11	100	65	500	393	560	520	1500	550	200	565	313	225	6xØ19 (M16)	553	1629	418	B95D
		160L	-	15	100	65	500	393	560	520	1500	550	200	565	313	225	6xØ19 (M16)	553	1629	463	B110C
		280S/M	90	-	100	65	578	393	820	770	1850	725	200	643	443	225	6xØ26 (M20)	908	2174	1170	B160B
		315S/M	132	-	100	65	578	393	860	810	2100	850	200	643	513	225	6xØ26 (M20)	1043	2347	1513	B160B
	8	160M	-	11	100	65	578	393	560	520	1650	625	200	721	313	225	6xØ19 (M16)	553	1722	445	B95D
		180M	-	18,5	100	65	578	393	560	520	1600	600	200	643	313	225	6xØ19 (M16)	594	1767	530	B110D
		315S/M	110	-	100	65	656	393	860	810	2250	925	200	799	513	225	6xØ26 (M20)	1043	2440	1492	B160B
		315S/M	160	-	100	65	656	393	860	810	2250	925	200	799	513	225	6xØ26 (M20)	1043	2440	1672	B160B
	9	160L	-	15	100	65	656	393	560	520	1650	625	200	721	313	225	6xØ19 (M16)	553	1785	514	B110C
		180M	-	18,5	100	65	656	393	560	520	1750	675	200	799	313	225	6xØ19 (M16)	594	1860	557	B110D
		315S/M	110	-	100	65	734	393	860	810	2250	925	200	799	513	225	6xØ26 (M20)	1043	2503	1516	B160B
		315S/M	132	-	100	65	734	393	860	810	2250	925	200	799	513	225	6xØ26 (M20)	1043	2503	1566	B160B
		315S/M	160	-	100	65	734	393	860	810	2250	925	200	799	513	225	6xØ26 (M20)	1043	2503	1696	B160B
	10	315L	200	-	100	65	734	393	860	810	2250	925	200	799	513	225	6xØ26 (M20)	1088	2612	1821	B180B
		160L	-	15	100	65	734	393	560	520	1800	700	200	877	313	225	6xØ19 (M16)	553	1878	541	B110C
		180L	-	22	100	65	734	393	560	520	1750	675	200	799	313	225	6xØ19 (M16)	594	1961	598	B110D
		315S/M	132	-	100	65	812	393	860	810	2400	950	250	955	513	225	6xØ26 (M20)	1043	2596	1595	B160B
	11	315L	200	-	100	65	812	393	860	810	2400	950	250	955	513	225	6xØ26 (M20)	1088	2705	1850	B180B
		180M	-	18,5	100	65	812	393	560	520	1900	750	200	955	313	225	6xØ19 (M16)	594	2016	608	B110D
		200L	-	30	100	65	812	393	650	610	1950	775	200	955	323	225	6xØ19 (M16)	642	2119	685	B125B
		180M	-	18,5	100	65	890	393	560	520	1900	750	200	955	313	225	6xØ19 (M16)	594	2079	632	B110D
	12	200L	-	30	100	65	890	393	650	610	1950	775	200	955	323	225	6xØ19 (M16)	642	2182	709	B125B
		180L	-	22	100	65	968	393	560	520	2050	825	200	1111	313	225	6xØ19 (M16)	594	2210	676	B110D
13	200L	-	30	100	65	968	393	650	610	2100	850	200	1111	323	225	6xØ19 (M16)	642	2275	736	B125B	
	180L	-	22	100	65	1046	393	560	520	2050	825	200	1111	313	225	6xØ19 (M16)	594	2273	700	B110D	
14	200L	-	30	100	65	1046	393	650	610	2100	850	200	1111	323	225	6xØ19 (M16)	642	2338	760	B125B	
	200L	-	30	100	65	1124	393	650	610	2300	900	250	1267	323	225	6xØ19 (M16)	642	2431	790	B125B	
15	225S/M	-	37	100	65	1124	393	660	610	2350	925	250	1267	373	225	6xØ19 (M16)	757	2550	954	B140B	
	200L	-	30	100	65	1202	393	650	610	2300	900	250	1267	323	225	6xØ19 (M16)	642	2494	814	B125B	
		225S/M	-	37	100	65	1202	393	660	610	2350	925	250	1267	373	225	6xØ19 (M16)	757	2613	978	B140B

e-MPR-AS-65-en_b_1d

NOTE. Pumps supplied with flanges according to EN 1092-2 as standard; available ASME B16.5 version on request.
For flanges dimensions see drawing on pages 92-93.

MPR SERIES - Size 100 DIMENSIONS AND WEIGHTS AT 50 Hz

PUMP TYPE MPR Size	NUMBER OF STAGES	IEC MOTOR FRAME	3000 [rpm]	1500 [rpm]	DIMENSIONS [mm]															WEIGHT G [kg]	COUPLING TYPE
					DNS	DND	a	f	B1	B2	L1	L2	L3	L4	H	h2	s	Hmax	Lmax		
100	1	200L	37	-	125	100	142	472	710	670	1400	500	200	307	363	275	6xØ19 (M16)	682	1550	589	B125C
		250S/M	55	-	125	100	142	472	720	670	1550	575	200	307	398	275	6xØ19 (M16)	796	1748	824	B140C
		132S/M	-	5,5	125	100	142	472	710	670	1200	400	200	307	358	275	6xØ19 (M16)	633	1268	390	B110E
	2	225S/M	45	-	125	100	232	472	720	670	1450	525	200	307	378	275	6xØ19 (M16)	762	1704	772	B125C
		250S/M	55	-	125	100	232	472	720	670	1550	575	200	307	398	275	6xØ19 (M16)	796	1813	862	B140C
		280S/M	75	-	125	100	232	472	820	770	1600	600	200	307	443	275	6xØ26 (M20)	908	1919	1110	B160C
		280S/M	90	-	125	100	232	472	820	770	1600	600	200	307	443	275	6xØ26 (M20)	908	1919	1140	B160C
		315S/M	110	-	125	100	232	472	860	810	1900	750	200	397	503	275	6xØ26 (M20)	1033	2117	1428	B160C
		132S/M	-	5,5	125	100	232	472	710	670	1200	400	200	307	358	275	6xØ19 (M16)	633	1333	428	B110E
		132S/M	-	7,5	125	100	232	472	710	670	1200	400	200	307	358	275	6xØ19 (M16)	633	1333	428	B110E
	160M	-	11	125	100	232	472	710	670	1350	475	200	307	363	275	6xØ19 (M16)	638	1452	455	B110F	
	3	280S/M	90	-	125	100	322	472	820	770	1800	700	200	487	443	275	6xØ26 (M20)	908	2034	1194	B160C
		315S/M	110	-	125	100	322	472	860	810	1900	750	200	397	503	275	6xØ26 (M20)	1033	2182	1466	B160C
		315S/M	132	-	125	100	322	472	860	810	1900	750	200	397	503	275	6xØ26 (M20)	1033	2182	1516	B160C
		315S/M	160	-	125	100	322	472	860	810	1900	750	200	397	503	275	6xØ26 (M20)	1033	2182	1646	B160C
		160M	-	11	125	100	322	472	710	670	1550	575	200	487	363	275	6xØ19 (M16)	638	1567	506	B110F
		160L	-	15	125	100	322	472	710	670	1550	575	200	487	363	275	6xØ19 (M16)	638	1567	550	B110F
	4	180M	-	18,5	125	100	322	472	710	670	1450	525	200	397	363	275	6xØ19 (M16)	644	1602	590	B110G
		315S/M	132	-	125	100	412	472	860	810	2100	850	200	577	503	275	6xØ26 (M20)	1033	2297	1600	B160C
		315S/M	160	-	125	100	412	472	860	810	2100	850	200	577	503	275	6xØ26 (M20)	1033	2297	1730	B160C
		315L	200	-	125	100	412	472	860	810	2100	850	200	577	503	275	6xØ26 (M20)	1078	2406	1854	B180D
		160L	-	15	125	100	412	472	710	670	1550	575	200	487	363	275	6xØ19 (M16)	638	1632	588	B110F
		180M	-	18,5	125	100	412	472	710	670	1650	625	200	577	363	275	6xØ19 (M16)	644	1717	635	B110G
	5	180L	-	22	125	100	412	472	710	670	1650	625	200	577	363	275	6xØ19 (M16)	644	1755	652	B110G
		315S/M	160	-	125	100	502	472	860	810	2100	850	200	577	503	275	6xØ26 (M20)	1033	2362	1768	B160C
		315L	200	-	125	100	502	472	860	810	2100	850	200	577	503	275	6xØ26 (M20)	1078	2471	1892	B180D
		315L	250	-	125	100	502	472	860	810	2100	850	200	577	503	275	6xØ26 (M20)	1078	2471	2042	B180D
		180L	-	22	125	100	502	472	710	670	1650	625	200	577	363	275	6xØ19 (M16)	644	1820	690	B110G
	6	200L	-	30	125	100	502	472	710	670	1800	700	200	667	363	275	6xØ19 (M16)	682	1910	744	B125C
		315L	200	-	125	100	592	472	860	810	2300	900	250	757	503	275	6xØ26 (M20)	1078	2586	1939	B180D
		315L	250	-	125	100	592	472	860	810	2300	900	250	757	503	275	6xØ26 (M20)	1078	2586	2089	B180D
		355M/L	315	-	125	100	592	472	1000	930	2400	950	250	757	583	275	6xØ29 (M24)	1203	2645	2807	B200B
		200L	-	30	125	100	592	472	710	670	1800	700	200	667	363	275	6xØ19 (M16)	682	1975	782	B125C
	7	225S/M	-	37	125	100	592	472	720	670	1950	775	200	757	378	275	6xØ19 (M16)	762	2119	942	B140C
		315L	250	-	125	100	682	472	860	810	2300	900	250	757	503	275	6xØ26 (M20)	1078	2651	2127	B180D
		355M/L	315	-	125	100	682	472	1000	930	2400	950	250	757	583	275	6xØ29 (M24)	1203	2710	2845	B200B
		355M/L	355	-	125	100	682	472	1000	930	2400	950	250	757	583	275	6xØ29 (M24)	1203	2710	2845	B200B
		200L	-	30	125	100	682	472	720	670	2050	825	200	937	383	275	6xØ19 (M16)	702	2180	847	B125C
		225S/M	-	37	125	100	682	472	720	670	1950	775	200	757	378	275	6xØ19 (M16)	762	2184	980	B140C
	8	225S/M	-	45	125	100	682	472	720	670	1950	775	200	757	378	275	6xØ19 (M16)	762	2184	1015	B140C
		225S/M	-	37	125	100	772	472	720	670	2150	875	200	937	398	275	6xØ26 (M20)	782	2299	1045	B140C
	9	225S/M	-	45	125	100	772	472	720	670	2150	875	200	937	398	275	6xØ26 (M20)	782	2299	1080	B140C
		250S/M	-	55	125	100	862	472	720	670	2200	900	200	937	418	275	6xØ26 (M20)	816	2443	1227	B160C
	10	225S/M	-	45	125	100	952	472	720	670	2300	900	250	1117	398	275	6xØ26 (M20)	782	2479	1160	B140C
		250S/M	-	55	125	100	952	472	720	670	2350	925	250	1117	418	275	6xØ26 (M20)	816	2558	1269	B160C
	11	250S/M	-	55	125	100	1042	472	720	670	2350	925	250	1117	418	275	6xØ26 (M20)	816	2623	1307	B160C
		280S/M	-	75	125	100	1042	472	820	770	2400	950	250	1117	443	275	6xØ26 (M20)	908	2729	1456	B180E

e-MPR-AS-100-en_b_1d

NOTE. Pumps supplied with flanges according to EN 1092-2 as standard; available ASME B16.5 version on request.
For flanges dimensions see drawing on pages 92-93.

MPR SERIES - Size 125 DIMENSIONS AND WEIGHTS AT 50 Hz

PUMP TYPE MPR Size	NUMBER OF STAGES	IEC MOTOR FRAME	3000 [rpm]	1500 [rpm]	DIMENSIONS [mm]														WEIGHT G [kg]	COUPLING TYPE	
					DNS	DND	a	f	B1	B2	L1	L2	L3	L4	H	h2	s	Hmax			Lmax
125	1	315S/M	110	-	150	125	173	488	860	810	1800	700	200	278	508	325	6xØ26 (M20)	1038	2069	1520	B160D
		315S/M	132	-	150	125	173	488	860	810	1800	700	200	278	508	325	6xØ26 (M20)	1038	2069	1570	B160D
		160M	-	11	150	125	173	488	750	710	1350	450	200	278	428	325	6xØ19 (M16)	753	1429	599	B125D
		180M	-	18,5	150	125	173	488	750	710	1350	475	200	278	428	325	6xØ19 (M16)	753	1489	682	B125E
	2	315S/M	132	-	150	125	285	488	860	810	1950	775	200	390	508	325	6xØ26 (M20)	1038	2181	1651	B160D
		315S/M	160	-	150	125	285	488	860	810	1950	775	200	390	508	325	6xØ26 (M20)	1038	2181	1781	B160D
		315L	200	-	150	125	285	488	860	810	1950	775	200	390	508	325	6xØ26 (M20)	1083	2290	1905	B180F
		315L	250	-	150	125	285	488	860	810	1950	775	200	390	508	325	6xØ26 (M20)	1083	2290	2055	B180F
		355M/L	315	-	150	125	285	488	1000	930	2050	825	200	390	588	325	6xØ29 (M24)	1208	2349	2773	B200D
		160L	-	15	150	125	285	488	750	710	1400	500	200	390	428	325	6xØ19 (M16)	753	1541	718	B125D
		180M	-	18,5	150	125	285	488	750	710	1450	525	200	390	428	325	6xØ19 (M16)	753	1601	757	B125E
		180L	-	22	150	125	285	488	750	710	1450	525	200	390	428	325	6xØ19 (M16)	753	1639	774	B125E
		200L	-	30	150	125	285	488	750	710	1500	550	200	390	428	325	6xØ19 (M16)	753	1704	822	B125F
		225S/M	-	37	150	125	285	488	760	710	1550	575	200	390	448	325	6xØ19 (M16)	832	1823	974	B140D
	3	315L	250	-	150	125	397	488	860	810	2050	825	200	502	508	325	6xØ26 (M20)	1083	2402	2131	B180F
		355M/L	315	-	150	125	397	488	1000	930	2200	900	200	502	588	325	6xØ29 (M24)	1208	2461	2856	B200D
		355M/L	355	-	150	125	397	488	1000	930	2200	900	200	502	588	325	6xØ29 (M24)	1208	2461	2856	B200D
		355A/B	400	-	150	125	397	488	1000	930	2300	900	250	502	588	325	6xØ29 (M24)	1313	2656	3172	B225C
		200L	-	30	150	125	397	488	750	710	1600	600	200	502	428	325	6xØ19 (M16)	753	1816	897	B125F
		225S/M	-	37	150	125	397	488	760	710	1650	625	200	502	448	325	6xØ19 (M16)	832	1935	1049	B140D
		225S/M	-	45	150	125	397	488	760	710	1650	625	200	502	448	325	6xØ19 (M16)	832	1935	1084	B140D
	4	250S/M	-	55	150	125	397	488	760	710	1750	675	200	502	448	325	6xØ19 (M16)	846	2014	1192	B160D
		355M/L	315	-	150	125	509	488	1000	930	2300	900	250	614	588	325	6xØ29 (M24)	1208	2573	2959	B200D
		355M/L	355	-	150	125	509	488	1000	930	2300	900	250	614	588	325	6xØ29 (M24)	1208	2573	2959	B200D
		355A/B	400	-	150	125	509	488	1000	930	2400	950	250	614	588	325	6xØ29 (M24)	1313	2768	3274	B225C
		355A/B	450	-	150	125	509	488	1000	930	2400	950	250	614	588	325	6xØ29 (M24)	1313	2768	3424	B225C
		400J/H	500	-	150	125	509	488	1140	1070	2700	1050	300	614	692	325	6xØ29 (M24)	1067	3161	4404	B225D
		400J/H	560	-	150	125	509	488	1140	1070	2700	1050	300	614	692	325	6xØ29 (M24)	1067	3161	4404	B225D
		225S/M	-	45	150	125	509	488	760	710	1800	700	200	614	448	325	6xØ19 (M16)	832	2047	1162	B140D
		250S/M	-	55	150	125	509	488	760	710	1850	725	200	614	448	325	6xØ19 (M16)	846	2126	1266	B160D
	5	280S/M	-	75	150	125	509	488	820	770	1950	775	200	614	468	325	6xØ26 (M20)	933	2232	1424	B180G
		355A/B	400	-	150	125	621	488	1000	930	2550	1025	250	726	588	325	6xØ29 (M24)	1313	2880	3352	B225C
		355A/B	450	-	150	125	621	488	1000	930	2550	1025	250	726	588	325	6xØ29 (M24)	1313	2880	3502	B225C
		400J/H	500	-	150	125	621	488	1140	1070	2850	1125	300	726	692	325	6xØ29 (M24)	1067	3273	4485	B225D
		400J/H	560	-	150	125	621	488	1140	1070	2850	1125	300	726	692	325	6xØ29 (M24)	1067	3273	4485	B225D
		400J/H	630	-	150	125	621	488	1140	1070	2850	1125	300	726	692	325	6xØ29 (M24)	1067	3273	4577	RWS252B
		280S/M	-	75	150	125	621	488	820	770	2050	825	200	726	468	325	6xØ26 (M20)	933	2344	1494	B180G
		280S/M	-	90	150	125	621	488	820	770	2050	825	200	726	468	325	6xØ26 (M20)	933	2344	1564	B180G
	6	280S/M	-	75	150	125	733	488	820	770	2150	875	200	838	468	325	6xØ26 (M20)	933	2456	1563	B180G
		315S/M	-	110	150	125	733	488	860	810	2400	950	250	838	508	325	6xØ26 (M20)	1038	2659	1964	B200E
7	280S/M	-	90	150	125	845	488	820	770	2250	925	200	950	468	325	6xØ26 (M20)	933	2568	1703	B180G	
	315S/M	-	110	150	125	845	488	860	810	2500	1000	250	950	508	325	6xØ26 (M20)	1038	2771	2034	B200E	
8	315S/M	-	110	150	125	957	488	860	810	2650	1075	250	1062	508	325	6xØ26 (M20)	1038	2883	2109	B200E	

e-MPR-AS-125-en_b_id

NOTE. Pumps supplied with flanges according to EN 1092-2 as standard; available ASME B16.5 version on request.
For flanges dimensions see drawing on pages 92-93.

MPD SERIES DIMENSIONS AND WEIGHTS AT 50 Hz

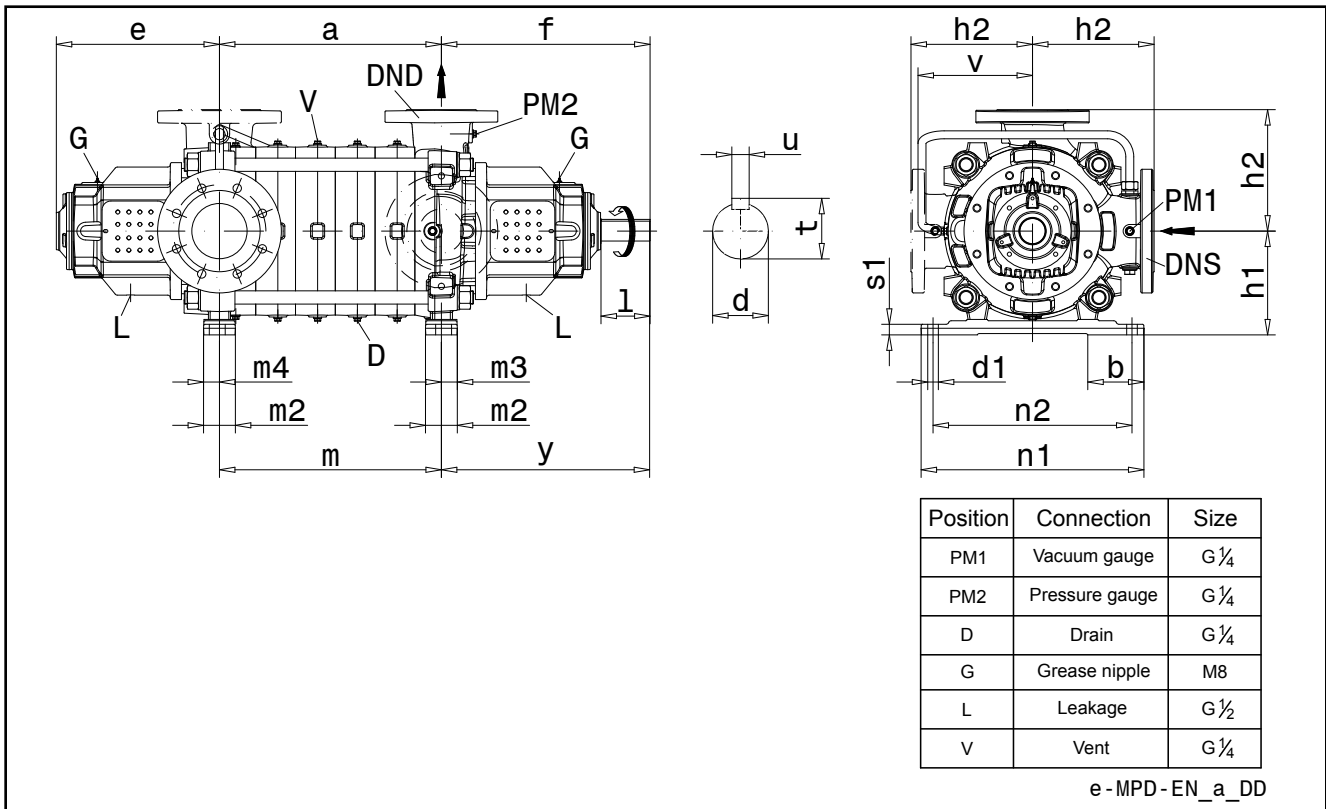

PUMP TYPE	DIMENSIONS [mm]																			
	MPD Size	Pump dimensions							Feet dimensions							Shaft end				
		DNS	DND	e	f	h1	h2	v	y	m2	m3	m4	n1	n2	b	d1	s1	d	t	u
50	80	50	282,5	350	150	200	200	350	54	24	27	332	290	90	14	21	28j6	31	8	70
65	100	65	319,4	393	190	225	225	393	60	30	30	410	365	99	19	20	35k6	38	10	80
100	125	100	369	472	235	275	275	472	72	36	36	504	450	125	24	24	45k6	48,5	14	110
125	150	125	392	488	300	325	325	488	90	45	45	610	560	209	26	50	52k6	56	16	110
150	200	150	469,3	580	350	400	400	580	100	40	40	735	680	260	26	50	60m6	64	18	135

NOTE. Pumps supplied with flanges according to EN 1092-2 as standard; available ASME B16.5 version on request.
For flanges dimensions see drawing on pages 92-93.

e-MPD-en_a_td

SIZE NUMBER OF STAGES	50			65			100			125			150		
	a	m	G [kg]	a	m	G [kg]	a	m	G [kg]	a	m	G [kg]	a	m	G [kg]
1	87	87	104	110	110	155	142	142	269	173	173	446	210	230	-
2	149	149	116	188	188	179	232	232	307	285	285	513	342	362	-
3	211	211	128	266	266	203	322	322	345	397	397	580	474	494	-
4	273	273	140	344	344	227	412	412	383	509	509	647	606	626	-
5	335	335	152	422	422	251	502	502	421	621	621	714	738	758	-
6	397	397	164	500	500	275	592	592	459	733	733	781	870	890	-
7	459	459	176	578	578	299	682	682	497	845	845	848			
8	521	521	188	656	656	323	772	772	535	957	957	915			
9	583	583	200	734	734	347	862	862	573						
10	645	645	212	812	812	371	952	952	611						
11	707	707	224	890	890	395	1042	1042	649						
12	769	769	236	968	968	419									
13	831	831	248	1046	1046	443									
14	893	893	260	1124	1124	467									
15	955	955	272	1202	1202	491									
16	1017	1017	284												
17	1079	1079	296												
18	1141	1141	308												

e-MPD-stage-en_b_td

MPD SERIES
DIMENSIONS AND WEIGHTS AT 50 Hz

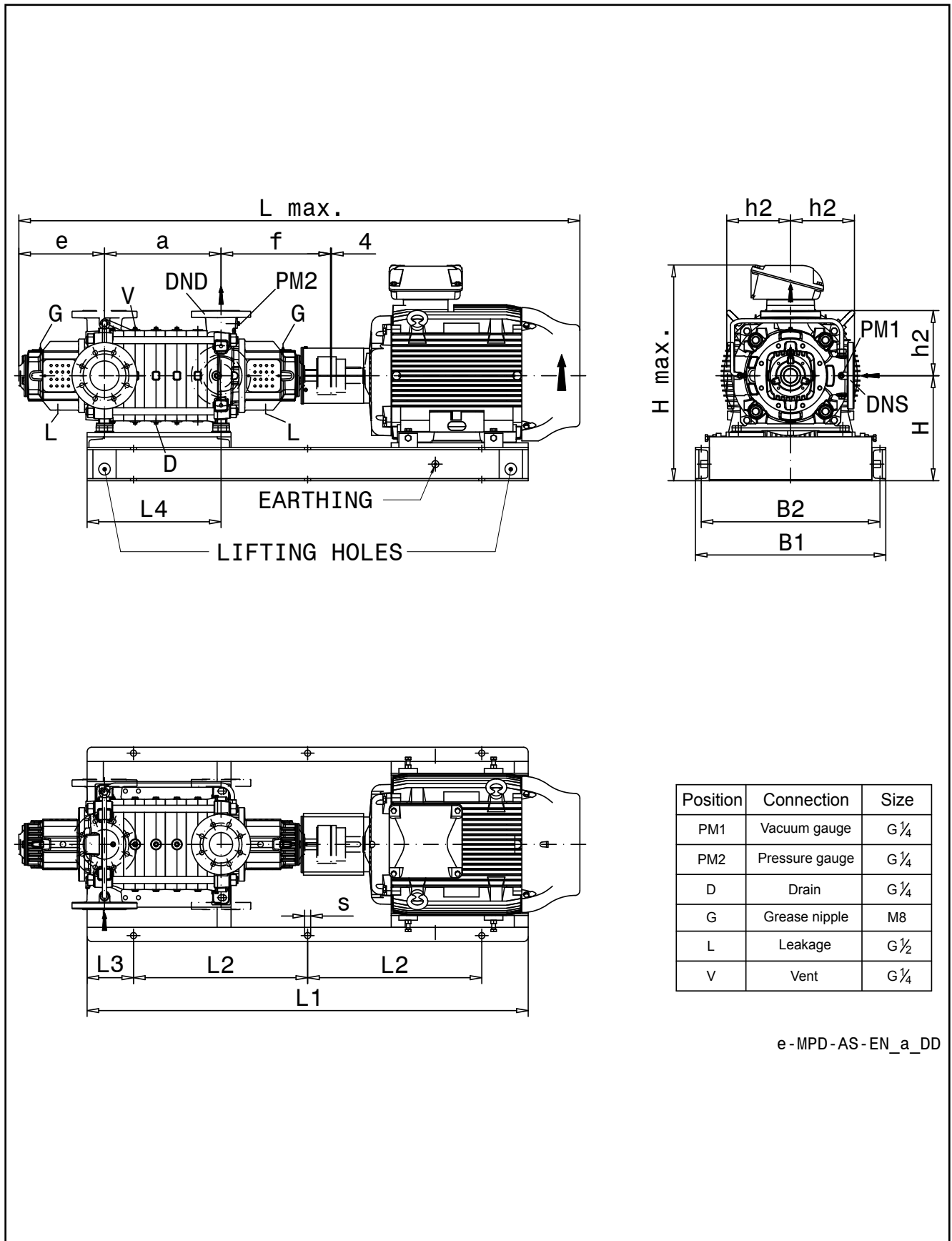

Position	Connection	Size
PM1	Vacuum gauge	G ¼
PM2	Pressure gauge	G ¼
D	Drain	G ¼
G	Grease nipple	M8
L	Leakage	G ½
V	Vent	G ¼

e-MPD-AS-EN_a_DD

MPD SERIES - Size 50

DIMENSIONS AND WEIGHTS AT 50 Hz

PUMP TYPE MPD Size	NUMBER OF STAGES	IEC MOTOR FRAME	3000 [rpm]	1500 [rpm]	DIMENSIONS [mm]																	WEIGHT G [kg]	COUPLING TYPE
					DNS	DND	a	e	f	B1	B2	L1	L2	L3	L4	H	h2	s	Hmax	Lmax			
50	1	132S/M	5,5	-	80	50	87	283	350	490	450	950	325	150	204	250	200	6xØ19 (M16)	450	1171	210	B80B	
		132S/M	7,5	-	80	50	87	283	350	490	450	950	325	150	204	250	200	6xØ19 (M16)	450	1171	206	B80B	
		100L	-	2,2	80	50	87	283	350	484	450	850	275	150	204	233	200	6xØ15 (M12)	433	1166	182	B80A	
	2	132S/M	5,5	-	80	50	149	283	350	490	450	950	325	150	204	250	200	6xØ19 (M16)	450	1233	222	B80B	
		132S/M	7,5	-	80	50	149	283	350	490	450	950	325	150	204	250	200	6xØ19 (M16)	450	1233	218	B80B	
		160M	11	-	80	50	149	283	350	490	450	1100	350	200	204	288	200	6xØ19 (M16)	528	1390	286	B95A	
		160M	15	-	80	50	149	283	350	490	450	1100	350	200	204	288	200	6xØ19 (M16)	528	1390	287	B95A	
		100L	-	2,2	80	50	149	283	350	484	450	850	275	150	204	233	200	6xØ15 (M12)	433	1228	194	B80A	
	3	160M	11	-	80	50	211	283	350	490	450	1200	400	200	328	288	200	6xØ19 (M16)	528	1452	302	B95A	
		160M	15	-	80	50	211	283	350	490	450	1200	400	200	328	288	200	6xØ19 (M16)	528	1452	303	B95A	
		160L	18,5	-	80	50	211	283	350	490	450	1200	400	200	328	288	200	6xØ19 (M16)	528	1452	310	B95A	
		180M	22	-	80	50	211	283	350	490	450	1200	400	200	266	308	200	6xØ19 (M16)	589	1512	373	B110B	
		100L	-	2,2	80	50	211	283	350	484	450	1000	350	150	328	233	200	6xØ15 (M12)	433	1290	211	B80A	
	4	100L	-	3	80	50	211	283	350	484	450	1000	350	150	328	233	200	6xØ15 (M12)	433	1290	215	B80A	
		160M	15	-	80	50	273	283	350	490	450	1200	400	200	328	288	200	6xØ19 (M16)	528	1514	315	B95A	
		160L	18,5	-	80	50	273	283	350	490	450	1200	400	200	328	288	200	6xØ19 (M16)	528	1514	322	B95A	
		180M	22	-	80	50	273	283	350	490	450	1300	450	200	390	308	200	6xØ19 (M16)	589	1574	390	B110B	
		200L	30	-	80	50	273	283	350	650	610	1300	450	200	328	328	200	6xØ19 (M16)	647	1677	479	B125A	
		100L	-	3	80	50	273	283	350	484	450	1000	350	150	328	233	200	6xØ15 (M12)	433	1352	227	B80A	
	5	112M	-	4	80	50	273	283	350	484	450	1050	375	150	390	233	200	6xØ15 (M12)	433	1352	245	B80A	
		180M	22	-	80	50	335	283	350	490	450	1300	450	200	390	308	200	6xØ19 (M16)	589	1636	402	B110B	
		200L	30	-	80	50	335	283	350	650	610	1450	525	200	452	328	200	6xØ19 (M16)	647	1739	503	B125A	
		200L	37	-	80	50	335	283	350	650	610	1450	525	200	452	328	200	6xØ19 (M16)	647	1739	518	B125A	
		100L	-	3	80	50	335	283	350	484	450	1100	400	150	452	233	200	6xØ15 (M12)	433	1414	240	B80A	
	6	112M	-	4	80	50	335	283	350	484	450	1050	375	150	390	233	200	6xØ15 (M12)	433	1414	257	B80A	
		200L	30	-	80	50	397	283	350	650	610	1450	525	200	452	328	200	6xØ19 (M16)	647	1801	515	B125A	
		200L	37	-	80	50	397	283	350	650	610	1450	525	200	452	328	200	6xØ19 (M16)	647	1801	530	B125A	
	7	112M	-	4	80	50	397	283	350	484	450	1200	450	150	514	233	200	6xØ15 (M12)	433	1476	272	B80A	
		132S/M	-	5,5	80	50	397	283	350	490	450	1200	450	150	514	250	200	6xØ19 (M16)	450	1519	284	B80B	
		200L	30	-	80	50	459	283	350	650	610	1550	575	200	576	328	200	6xØ19 (M16)	647	1863	528	B125A	
		200L	37	-	80	50	459	283	350	650	610	1550	575	200	576	328	200	6xØ19 (M16)	647	1863	543	B125A	
		225S/M	45	-	80	50	459	283	350	660	610	1600	600	200	576	368	200	6xØ19 (M16)	752	1952	699	B125A	
	8	112M	-	4	80	50	459	283	350	484	450	1200	450	150	514	233	200	6xØ15 (M12)	433	1538	284	B80A	
		132S/M	-	5,5	80	50	459	283	350	490	450	1350	525	150	576	250	200	6xØ19 (M16)	450	1581	299	B80B	
		200L	37	-	80	50	521	283	350	650	610	1550	575	200	576	328	200	6xØ19 (M16)	647	1925	555	B125A	
		225S/M	45	-	80	50	521	283	350	660	610	1600	600	200	576	368	200	6xØ19 (M16)	752	2014	711	B125A	
		250S/M	55	-	80	50	521	283	350	720	670	1700	650	200	576	393	200	6xØ19 (M16)	791	2123	808	B140A	
	9	132S/M	-	5,5	80	50	521	283	350	490	450	1350	525	150	576	250	200	6xØ19 (M16)	450	1643	311	B80B	
		132S/M	-	7,5	80	50	521	283	350	490	450	1350	525	150	576	250	200	6xØ19 (M16)	450	1643	311	B80B	
		225S/M	45	-	80	50	583	283	350	660	610	1700	650	200	700	368	200	6xØ19 (M16)	752	2076	725	B125A	
		250S/M	55	-	80	50	583	283	350	720	670	1800	700	200	700	393	200	6xØ19 (M16)	791	2185	821	B140A	
		280S/M	75	-	80	50	583	283	350	820	770	1900	750	200	700	448	200	6xØ19 (M16)	913	2291	1063	B160A	
	10	132S/M	-	5,5	80	50	583	283	350	490	450	1450	575	150	700	250	200	6xØ19 (M16)	450	1705	325	B80B	
		132S/M	-	7,5	80	50	583	283	350	490	450	1450	575	150	700	250	200	6xØ19 (M16)	450	1705	325	B80B	
		225S/M	45	-	80	50	645	283	350	660	610	1700	650	200	700	368	200	6xØ19 (M16)	752	2138	737	B125A	
		250S/M	55	-	80	50	645	283	350	720	670	1800	700	200	700	393	200	6xØ19 (M16)	791	2247	833	B140A	
		280S/M	75	-	80	50	645	283	350	820	770	1900	750	200	700	448	200	6xØ19 (M16)	913	2353	1075	B160A	
	11	132S/M	-	7,5	80	50	645	283	350	490	450	1450	575	150	700	250	200	6xØ19 (M16)	450	1767	337	B80B	
		160M	-	11	80	50	645	283	350	490	450	1600	600	200	700	288	200	6xØ19 (M16)	528	1886	379	B95A	
		250S/M	55	-	80	50	707	283	350	720	670	1900	750	200	824	393	200	6xØ19 (M16)	791	2309	847	B140A	
		280S/M	75	-	80	50	707	283	350	820	770	2000	800	200	824	448	200	6xØ19 (M16)	913	2415	1120	B160A	
	12	132S/M	-	7,5	80	50	707	283	350	490	450	1600	650	150	824	250	200	6xØ19 (M16)	450	1829	352	B80B	
		160M	-	11	80	50	707	283	350	490	450	1700	650	200	824	288	200	6xØ19 (M16)	528	1948	392	B95A	
		280S/M	75	-	80	50	769	283	350	820	770	2000	800	200	824	448	200	6xØ19 (M16)	913	2477	1132	B160A	
		280S/M	90	-	80	50	769	283	350	820	770	2000	800	200	824	448	200	6xØ19 (M16)	913	2477	1162	B160A	
	13	132S/M	-	7,5	80	50	769	283	350	490	450	1600	650	150	824	250	200	6xØ19 (M16)	450	1891	364	B80B	
		160M	-	11	80	50	769	283	350	490	450	1700	650	200	824	288	200	6xØ19 (M16)	528	2010	404	B95A	
		280S/M	75	-	80	50	831	283	350	820	770	2150	875	200	948	448	200	6xØ19 (M16)	913	2539	1150	B160A	
		280S/M	90	-	80	50	831	283	350	820	770	2150	875	200	948	448	200	6xØ19 (M16)	913	2539	1180	B160A	

MPD SERIES - Size 65 DIMENSIONS AND WEIGHTS AT 50 Hz

PUMP TYPE MPD Size	NUMBER OF STAGES	IEC MOTOR FRAME	3000 [rpm]		1500 [rpm]		DIMENSIONS [mm]																WEIGHT G [kg]	COUPLING TYPE
			[kW]	[kW]	DNS	DND	a	e	f	B1	B2	L1	L2	L3	L4	H	h2	s	Hmax	Lmax				
65	1	160M	15	-	100	65	110	319	393	560	520	1150	375	200	253	313	225	6xØ19 (M16)	553	1430	335	B95D		
		160L	18,5	-	100	65	110	319	393	560	520	1150	375	200	253	313	225	6xØ19 (M16)	553	1430	342	B95D		
		100L	-	2,2	100	65	110	319	393	550	510	950	325	150	253	293	225	6xØ19 (M16)	518	1268	255	B95B		
	2	160L	18,5	-	100	65	188	319	393	560	520	1150	375	200	253	313	225	6xØ19 (M16)	553	1508	366	B95D		
		180M	22	-	100	65	188	319	393	560	520	1200	400	200	253	313	225	6xØ19 (M16)	594	1568	429	B110D		
		200L	30	-	100	65	188	319	393	650	610	1250	425	200	253	323	225	6xØ19 (M16)	642	1671	510	B125B		
		200L	37	-	100	65	188	319	393	650	610	1250	425	200	253	323	225	6xØ19 (M16)	642	1671	525	B125B		
		112M	-	4	100	65	188	319	393	550	510	950	325	150	253	293	225	6xØ19 (M16)	518	1346	299	B95B		
		132S/M	-	5,5	100	65	188	319	393	550	510	1100	400	150	331	293	225	6xØ19 (M16)	518	1389	307	B95C		
	3	200L	37	-	100	65	266	319	393	650	610	1400	500	200	409	323	225	6xØ19 (M16)	642	1749	556	B125B		
		225S/M	45	-	100	65	266	319	393	660	610	1450	525	200	409	373	225	6xØ19 (M16)	757	1838	707	B125B		
		250S/M	55	-	100	65	266	319	393	720	670	1550	575	200	409	393	225	6xØ19 (M16)	791	1947	800	B140B		
		132S/M	-	5,5	100	65	266	319	393	550	510	1100	400	150	331	293	225	6xØ19 (M16)	518	1467	331	B95C		
	4	132S/M	-	7,5	100	65	266	319	393	550	510	1100	400	150	331	293	225	6xØ19 (M16)	518	1467	331	B95C		
		225S/M	45	-	100	65	344	319	393	660	610	1450	525	200	409	373	225	6xØ19 (M16)	757	1916	731	B125B		
250S/M		55	-	100	65	344	319	393	720	670	1550	575	200	409	393	225	6xØ19 (M16)	791	2025	824	B140B			
280S/M		75	-	100	65	344	319	393	820	770	1700	650	200	487	443	225	6xØ26 (M20)	908	2131	1093	B160B			
5	132S/M	-	7,5	100	65	344	319	393	550	510	1300	500	150	487	293	225	6xØ19 (M16)	518	1545	361	B95C			
	160M	-	11	100	65	344	319	393	560	520	1350	475	200	409	313	225	6xØ19 (M16)	553	1664	397	B95D			
	280S/M	75	-	100	65	422	319	393	820	770	1700	650	200	487	443	225	6xØ26 (M20)	908	2209	1117	B160B			
	280S/M	90	-	100	65	422	319	393	820	770	1700	650	200	487	443	225	6xØ26 (M20)	908	2209	1147	B160B			
6	315S/M	110	-	100	65	422	319	393	860	810	1950	775	200	487	513	225	6xØ26 (M20)	1043	2382	1439	B160B			
	160M	-	11	100	65	422	319	393	560	520	1500	550	200	565	313	225	6xØ19 (M16)	553	1742	424	B95D			
	160L	-	15	100	65	422	319	393	560	520	1500	550	200	565	313	225	6xØ19 (M16)	553	1742	469	B110C			
	280S/M	75	-	100	65	500	319	393	820	770	1850	725	200	643	443	225	6xØ26 (M20)	908	2287	1146	B160B			
7	280S/M	90	-	100	65	500	319	393	820	770	1850	725	200	643	443	225	6xØ26 (M20)	908	2287	1176	B160B			
	315S/M	110	-	100	65	500	319	393	860	810	2100	850	200	643	513	225	6xØ26 (M20)	1043	2460	1469	B160B			
	160M	-	11	100	65	500	319	393	560	520	1500	550	200	565	313	225	6xØ19 (M16)	553	1820	448	B95D			
	160L	-	15	100	65	500	319	393	560	520	1500	550	200	565	313	225	6xØ19 (M16)	553	1820	493	B110C			
8	280S/M	90	-	100	65	578	319	393	820	770	1850	725	200	643	443	225	6xØ26 (M20)	908	2365	1200	B160B			
	315S/M	132	-	100	65	578	319	393	860	810	2100	850	200	643	513	225	6xØ26 (M20)	1043	2538	1543	B160B			
	160M	-	11	100	65	578	319	393	560	520	1650	625	200	721	313	225	6xØ19 (M16)	553	1898	475	B95D			
	180M	-	18,5	100	65	578	319	393	560	520	1600	600	200	643	313	225	6xØ19 (M16)	594	1958	560	B110D			
9	315S/M	110	-	100	65	656	319	393	860	810	2250	925	200	799	513	225	6xØ26 (M20)	1043	2616	1522	B160B			
	315S/M	160	-	100	65	656	319	393	860	810	2250	925	200	799	513	225	6xØ26 (M20)	1043	2616	1702	B160B			
	160L	-	15	100	65	656	319	393	560	520	1650	625	200	721	313	225	6xØ19 (M16)	553	1976	544	B110C			
	180M	-	18,5	100	65	656	319	393	560	520	1750	675	200	799	313	225	6xØ19 (M16)	594	2036	587	B110D			
10	315S/M	110	-	100	65	734	319	393	860	810	2250	925	200	799	513	225	6xØ26 (M20)	1043	2694	1546	B160B			
	315S/M	132	-	100	65	734	319	393	860	810	2250	925	200	799	513	225	6xØ26 (M20)	1043	2694	1596	B160B			
	315S/M	160	-	100	65	734	319	393	860	810	2250	925	200	799	513	225	6xØ26 (M20)	1043	2694	1726	B160B			
	315L	200	-	100	65	734	319	393	860	810	2250	925	200	799	513	225	6xØ26 (M20)	1088	2803	1851	B180B			
11	160L	-	15	100	65	734	319	393	560	520	1800	700	200	877	313	225	6xØ19 (M16)	553	2054	571	B110C			
	180L	-	22	100	65	734	319	393	560	520	1750	675	200	799	313	225	6xØ19 (M16)	594	2152	628	B110D			
	315S/M	132	-	100	65	812	319	393	860	810	2400	950	250	955	513	225	6xØ26 (M20)	1043	2772	1625	B160B			
	315L	200	-	100	65	812	319	393	860	810	2400	950	250	955	513	225	6xØ26 (M20)	1088	2881	1880	B180B			
12	180M	-	18,5	100	65	812	319	393	560	520	1900	750	200	955	313	225	6xØ19 (M16)	594	2192	638	B110D			
	200L	-	30	100	65	812	319	393	650	610	1950	775	200	955	323	225	6xØ19 (M16)	642	2295	715	B125B			
	180M	-	18,5	100	65	890	319	393	560	520	1900	750	200	955	313	225	6xØ19 (M16)	594	2270	662	B110D			
	200L	-	30	100	65	890	319	393	650	610	1950	775	200	955	323	225	6xØ19 (M16)	642	2373	739	B125B			
13	180L	-	22	100	65	968	319	393	560	520	2050	825	200	1111	313	225	6xØ19 (M16)	594	2386	706	B110D			
	200L	-	30	100	65	968	319	393	650	610	2100	850	200	1111	323	225	6xØ19 (M16)	642	2451	766	B125B			
14	180L	-	22	100	65	1046	319	393	560	520	2050	825	200	1111	313	225	6xØ19 (M16)	594	2464	730	B110D			
	200L	-	30	100	65	1046	319	393	650	610	2100	850	200	1111	323	225	6xØ19 (M16)	642	2529	790	B125B			
15	200L	-	30	100	65	1124	319	393	650	610	2300	900	250	1267	323	225	6xØ19 (M16)	642	2607	820	B125B			
	225S/M	-	37	100	65	1124	319	393	660	610	2350	925	250	1267	373	225	6xØ19 (M16)	757	2726	984	B140B			
16	200L	-	30	100	65	1202	319	393	650	610	2300	900	250	1267	323	225	6xØ19 (M16)	642	2685	844	B125B			
	225S/M	-	37	100	65	1202	319	393	660	610	2350	925	250	1267	373	225	6xØ19 (M16)	757	2804	1008	B140B			

NOTE. Pumps supplied with flanges according to EN 1092-2 as standard; available ASME B16.5 version on request.
For flanges dimensions see drawing on pages 92-93.

e-MPD-AS-65-en_b_1d

MPD SERIES - Size 100 DIMENSIONS AND WEIGHTS AT 50 Hz

PUMP TYPE MPD Size	NUMBER OF STAGES	IEC MOTOR FRAME	3000 [rpm]	1500 [rpm]	DIMENSIONS [mm]															WEIGHT G [kg]	COUPLING TYPE	
					[kW]	[kW]	DNS	DND	a	e	f	B1	B2	L1	L2	L3	L4	H	h2			s
100	1	200L	37	-	125	100	142	369	472	710	670	1400	500	200	307	363	275	6xØ19 (M16)	682	1754	632	B125C
		250S/M	55	-	125	100	142	369	472	720	670	1550	575	200	307	398	275	6xØ19 (M16)	796	1952	867	B140C
		132S/M	-	5,5	125	100	142	369	472	710	670	1200	400	200	307	358	275	6xØ19 (M16)	633	1472	433	B110E
	2	225S/M	45	-	125	100	232	369	472	720	670	1450	525	200	307	378	275	6xØ19 (M16)	762	1933	815	B125C
		250S/M	55	-	125	100	232	369	472	720	670	1550	575	200	307	398	275	6xØ19 (M16)	796	2042	905	B140C
		280S/M	75	-	125	100	232	369	472	820	770	1600	600	200	307	443	275	6xØ26 (M20)	908	2148	1153	B160C
		280S/M	90	-	125	100	232	369	472	820	770	1600	600	200	307	443	275	6xØ26 (M20)	908	2148	1183	B160C
		315S/M	110	-	125	100	232	369	472	860	810	1900	750	200	397	503	275	6xØ26 (M20)	1033	2321	1471	B160C
		132S/M	-	5,5	125	100	232	369	472	710	670	1200	400	200	307	358	275	6xØ19 (M16)	633	1562	471	B110E
		132S/M	-	7,5	125	100	232	369	472	710	670	1200	400	200	307	358	275	6xØ19 (M16)	633	1562	471	B110E
		160M	-	11	125	100	232	369	472	710	670	1350	475	200	307	363	275	6xØ19 (M16)	638	1681	498	B110F
	3	280S/M	90	-	125	100	322	369	472	820	770	1800	700	200	487	443	275	6xØ26 (M20)	908	2238	1237	B160C
		315S/M	110	-	125	100	322	369	472	860	810	1900	750	200	397	503	275	6xØ26 (M20)	1033	2411	1509	B160C
		315S/M	132	-	125	100	322	369	472	860	810	1900	750	200	397	503	275	6xØ26 (M20)	1033	2411	1559	B160C
		315S/M	160	-	125	100	322	369	472	860	810	1900	750	200	397	503	275	6xØ26 (M20)	1033	2411	1689	B160C
		160M	-	11	125	100	322	369	472	710	670	1550	575	200	487	363	275	6xØ19 (M16)	638	1771	549	B110F
		160L	-	15	125	100	322	369	472	710	670	1550	575	200	487	363	275	6xØ19 (M16)	638	1771	593	B110F
	4	180M	-	18,5	125	100	322	369	472	710	670	1450	525	200	397	363	275	6xØ19 (M16)	644	1831	633	B110G
		315S/M	132	-	125	100	412	369	472	860	810	2100	850	200	577	503	275	6xØ26 (M20)	1033	2501	1643	B160C
		315S/M	160	-	125	100	412	369	472	860	810	2100	850	200	577	503	275	6xØ26 (M20)	1033	2501	1773	B160C
		315L	200	-	125	100	412	369	472	860	810	2100	850	200	577	503	275	6xØ26 (M20)	1078	2610	1897	B180D
		160L	-	15	125	100	412	369	472	710	670	1550	575	200	487	363	275	6xØ19 (M16)	638	1861	631	B110F
	5	180M	-	18,5	125	100	412	369	472	710	670	1650	625	200	577	363	275	6xØ19 (M16)	644	1921	678	B110G
		180L	-	22	125	100	412	369	472	710	670	1650	625	200	577	363	275	6xØ19 (M16)	644	1959	695	B110G
		315S/M	160	-	125	100	502	369	472	860	810	2100	850	200	577	503	275	6xØ26 (M20)	1033	2591	1811	B160C
		315L	200	-	125	100	502	369	472	860	810	2100	850	200	577	503	275	6xØ26 (M20)	1078	2700	1935	B180D
		315L	250	-	125	100	502	369	472	860	810	2100	850	200	577	503	275	6xØ26 (M20)	1078	2700	2085	B180D
	6	180L	-	22	125	100	502	369	472	710	670	1650	625	200	577	363	275	6xØ19 (M16)	644	2049	733	B110G
		200L	-	30	125	100	502	369	472	710	670	1800	700	200	667	363	275	6xØ19 (M16)	682	2114	787	B125C
		315L	200	-	125	100	592	369	472	860	810	2300	900	250	757	503	275	6xØ26 (M20)	1078	2790	1982	B180D
		315L	250	-	125	100	592	369	472	860	810	2300	900	250	757	503	275	6xØ26 (M20)	1078	2790	2132	B180D
		355M/L	315	-	125	100	592	369	472	1000	930	2400	950	250	757	583	275	6xØ29 (M24)	1203	2849	2850	B200B
	7	200L	-	30	125	100	592	369	472	710	670	1800	700	200	667	363	275	6xØ19 (M16)	682	2204	825	B125C
		225S/M	-	37	125	100	592	369	472	720	670	1950	775	200	757	378	275	6xØ19 (M16)	762	2323	985	B140C
		315L	250	-	125	100	682	369	472	860	810	2300	900	250	757	503	275	6xØ26 (M20)	1078	2880	2170	B180D
		355M/L	315	-	125	100	682	369	472	1000	930	2400	950	250	757	583	275	6xØ29 (M24)	1203	2939	2888	B200B
		355M/L	355	-	125	100	682	369	472	1000	930	2400	950	250	757	583	275	6xØ29 (M24)	1203	2939	2888	B200B
	8	200L	-	30	125	100	682	369	472	720	670	2050	825	200	937	383	275	6xØ19 (M16)	702	2294	890	B125C
		225S/M	-	37	125	100	682	369	472	720	670	1950	775	200	757	378	275	6xØ19 (M16)	762	2413	1023	B140C
		225S/M	-	45	125	100	682	369	472	720	670	1950	775	200	757	378	275	6xØ19 (M16)	762	2413	1058	B140C
		225S/M	-	37	125	100	772	369	472	720	670	2150	875	200	937	398	275	6xØ26 (M20)	782	2503	1088	B140C
	9	225S/M	-	45	125	100	772	369	472	720	670	2150	875	200	937	398	275	6xØ26 (M20)	782	2503	1123	B140C
		225S/M	-	45	125	100	862	369	472	720	670	2150	875	200	937	398	275	6xØ26 (M20)	782	2593	1161	B140C
		250S/M	-	55	125	100	862	369	472	720	670	2200	900	200	937	418	275	6xØ26 (M20)	816	2672	1270	B160C
	10	225S/M	-	45	125	100	952	369	472	720	670	2300	900	250	1117	398	275	6xØ26 (M20)	782	2683	1203	B140C
		250S/M	-	55	125	100	952	369	472	720	670	2350	925	250	1117	418	275	6xØ26 (M20)	816	2762	1312	B160C
	11	250S/M	-	55	125	100	1042	369	472	720	670	2350	925	250	1117	418	275	6xØ26 (M20)	816	2852	1350	B160C
		280S/M	-	75	125	100	1042	369	472	820	770	2400	950	250	1117	443	275	6xØ26 (M20)	908	2958	1499	B180E

e-MPD-AS-100-en_b_id

NOTE. Pumps supplied with flanges according to EN 1092-2 as standard; available ASME B16.5 version on request.
For flanges dimensions see drawing on pages 92-93.

MPD SERIES - Size 125 DIMENSIONS AND WEIGHTS AT 50 Hz

PUMP TYPE MPD Size	NUMBER OF STAGES	IEC MOTOR FRAME	3000 [rpm]	1500 [rpm]	DIMENSIONS [mm]															WEIGHT G [kg]	COUPLING TYPE	
					[kW]	[kW]	DNS	DND	a	e	f	B1	B2	L1	L2	L3	L4	H	h2			s
125	1	315S/M	110	-	150	125	173	392	488	860	810	1800	700	200	278	508	325	6xØ26 (M20)	1038	2301	1583	B160D
		315S/M	132	-	150	125	173	392	488	860	810	1800	700	200	278	508	325	6xØ26 (M20)	1038	2301	1633	B160D
		160M	-	11	150	125	173	392	488	750	710	1300	450	200	278	428	325	6xØ19 (M16)	753	1661	662	B125D
		180M	-	18,5	150	125	173	392	488	750	710	1350	475	200	278	428	325	6xØ19 (M16)	753	1721	745	B125E
	2	315S/M	132	-	150	125	285	392	488	860	810	1950	775	200	390	508	325	6xØ26 (M20)	1038	2413	1714	B160D
		315S/M	160	-	150	125	285	392	488	860	810	1950	775	200	390	508	325	6xØ26 (M20)	1038	2413	1844	B160D
		315L	200	-	150	125	285	392	488	860	810	1950	775	200	390	508	325	6xØ26 (M20)	1083	2522	1968	B180F
		315L	250	-	150	125	285	392	488	860	810	1950	775	200	390	508	325	6xØ26 (M20)	1083	2522	2118	B180F
		355M/L	315	-	150	125	285	392	488	1000	930	2050	825	200	390	588	325	6xØ29 (M24)	1208	2581	2836	B200D
		160L	-	15	150	125	285	392	488	750	710	1400	500	200	390	428	325	6xØ19 (M16)	753	1773	781	B125D
		180M	-	18,5	150	125	285	392	488	750	710	1450	525	200	390	428	325	6xØ19 (M16)	753	1833	820	B125E
		180L	-	22	150	125	285	392	488	750	710	1450	525	200	390	428	325	6xØ19 (M16)	753	1871	837	B125E
		200L	-	30	150	125	285	392	488	750	710	1500	550	200	390	428	325	6xØ19 (M16)	753	1936	885	B125F
		225S/M	-	37	150	125	285	392	488	760	710	1550	575	200	390	448	325	6xØ19 (M16)	832	2055	1037	B140D
	3	315L	250	-	150	125	397	392	488	860	810	2050	825	200	502	508	325	6xØ26 (M20)	1083	2634	2194	B180F
		355M/L	315	-	150	125	397	392	488	1000	930	2200	900	200	502	588	325	6xØ29 (M24)	1208	2693	2919	B200D
		355M/L	355	-	150	125	397	392	488	1000	930	2200	900	200	502	588	325	6xØ29 (M24)	1208	2693	2919	B200D
		355A/B	400	-	150	125	397	392	488	1000	930	2300	900	250	502	588	325	6xØ29 (M24)	1313	2888	3235	B225C
		200L	-	30	150	125	397	392	488	750	710	1600	600	200	502	428	325	6xØ19 (M16)	753	2048	960	B125F
		225S/M	-	37	150	125	397	392	488	760	710	1650	625	200	502	448	325	6xØ19 (M16)	832	2167	1112	B140D
		225S/M	-	45	150	125	397	392	488	760	710	1650	625	200	502	448	325	6xØ19 (M16)	832	2167	1147	B140D
	250S/M	-	55	150	125	397	392	488	760	710	1750	675	200	502	448	325	6xØ19 (M16)	846	2246	1255	B160D	
	4	355M/L	315	-	150	125	509	392	488	1000	930	2300	900	250	614	588	325	6xØ29 (M24)	1208	2805	3022	B200D
		355M/L	355	-	150	125	509	392	488	1000	930	2300	900	250	614	588	325	6xØ29 (M24)	1208	2805	3022	B200D
		355A/B	400	-	150	125	509	392	488	1000	930	2400	950	250	614	588	325	6xØ29 (M24)	1313	3000	3337	B225C
		355A/B	450	-	150	125	509	392	488	1000	930	2400	950	250	614	588	325	6xØ29 (M24)	1313	3000	3487	B225C
		400J/H	500	-	150	125	509	392	488	1140	1070	2700	1050	300	614	692	325	6xØ29 (M24)	1067	3393	4467	B225D
		400J/H	560	-	150	125	509	392	488	1140	1070	2700	1050	300	614	692	325	6xØ29 (M24)	1067	3393	4467	B225D
		225S/M	-	45	150	125	509	392	488	760	710	1800	700	200	614	448	325	6xØ19 (M16)	832	2279	1225	B140D
		250S/M	-	55	150	125	509	392	488	760	710	1850	725	200	614	448	325	6xØ19 (M16)	846	2358	1329	B160D
	280S/M	-	75	150	125	509	392	488	820	770	1950	775	200	614	468	325	6xØ26 (M20)	933	2464	1487	B180G	
	5	355A/B	400	-	150	125	621	392	488	1000	930	2550	1025	250	726	588	325	6xØ29 (M24)	1313	3112	3415	B225C
		355A/B	450	-	150	125	621	392	488	1000	930	2550	1025	250	726	588	325	6xØ29 (M24)	1313	3112	3565	B225C
		400J/H	500	-	150	125	621	392	488	1140	1070	2850	1125	300	726	692	325	6xØ29 (M24)	1067	3505	4548	B225D
		400J/H	560	-	150	125	621	392	488	1140	1070	2850	1125	300	726	692	325	6xØ29 (M24)	1067	3505	4548	B225D
		400J/H	630	-	150	125	621	392	488	1140	1070	2850	1125	300	726	692	325	6xØ29 (M24)	1067	3505	4640	RWS252B
		280S/M	-	75	150	125	621	392	488	820	770	2050	825	200	726	468	325	6xØ26 (M20)	933	2576	1557	B180G
	6	280S/M	-	90	150	125	621	392	488	820	770	2050	825	200	726	468	325	6xØ26 (M20)	933	2576	1627	B180G
		315S/M	-	75	150	125	733	392	488	820	770	2150	875	200	838	468	325	6xØ26 (M20)	933	2688	1626	B180G
	7	315S/M	-	110	150	125	733	392	488	860	810	2400	950	250	838	508	325	6xØ26 (M20)	1038	2891	2027	B200E
		280S/M	-	90	150	125	845	392	488	820	770	2250	925	200	950	468	325	6xØ26 (M20)	933	2800	1766	B180G
	8	315S/M	-	110	150	125	845	392	488	860	810	2500	1000	250	950	508	325	6xØ26 (M20)	1038	3003	2097	B200E
		315S/M	-	110	150	125	957	392	488	860	810	2650	1075	250	1062	508	325	6xØ26 (M20)	1038	3115	2172	B200E

e-MPD-AS-125-en_b_td

NOTE. Pumps supplied with flanges according to EN 1092-2 as standard; available ASME B16.5 version on request.
For flanges dimensions see drawing on pages 92-93.

MPV SERIES
DIMENSIONS AND WEIGHTS AT 50 Hz

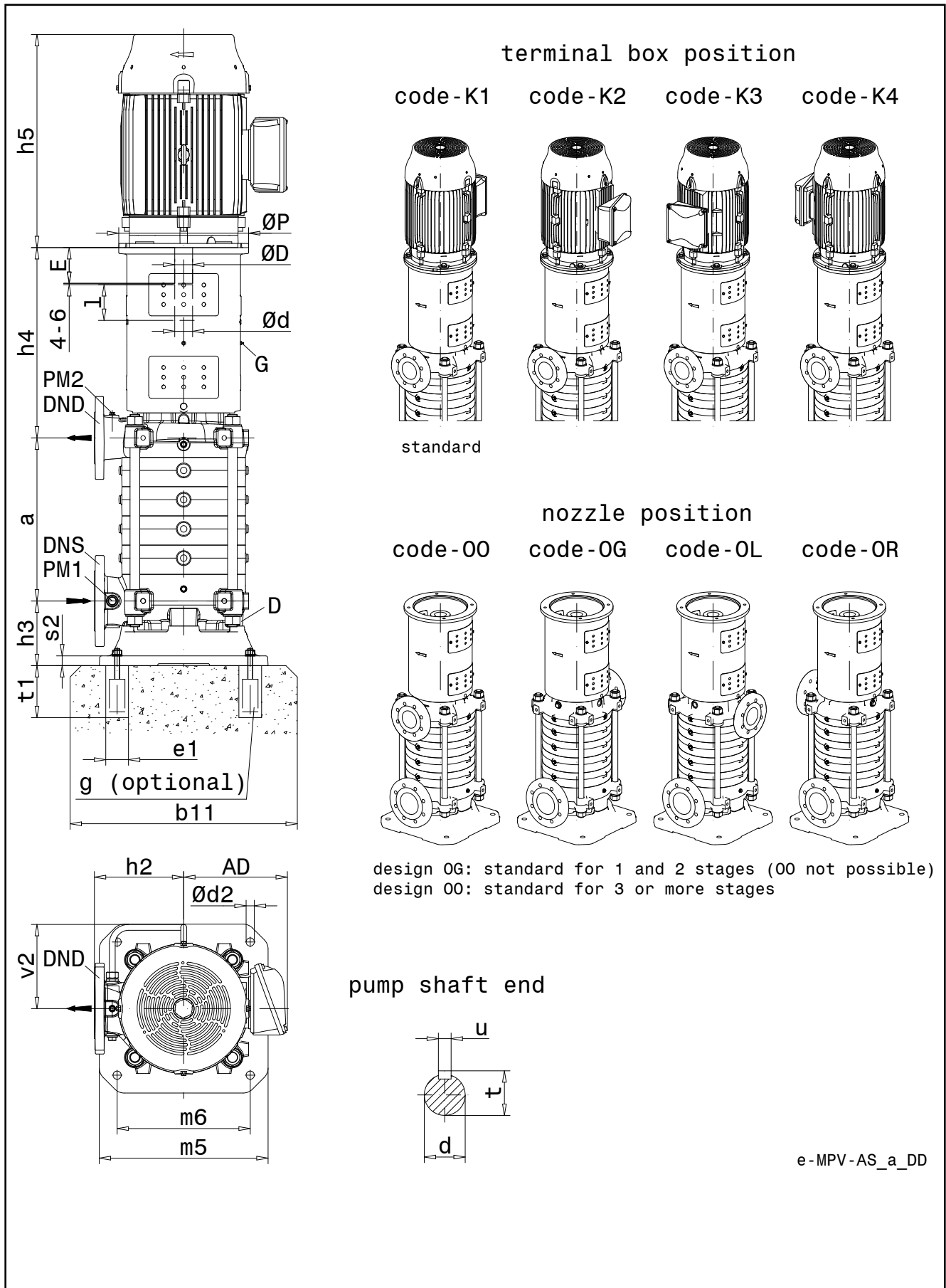

e-MPV-AS_a_DD

MPV SERIES DIMENSIONS AND WEIGHTS AT 50 Hz

PUMP TYPE MPV Size	DIMENSIONS [mm]																
	Pump dimensions													Base dimensions			
	DNS	DND	h2	h3	d2	m5	m6	s2	v2	d	t	u	l	b11	e1	t1	g
50	80	50	200	136	20	375	280	24	200	28j6	31	8	70	580	80	300	M16x300
65	100	65	225	165	20	440	340	27	225	35k6	38	10	80	640	80	300	M16x300
100	125	100	275	199	25	520	410	30	275	45k6	48,5	14	110	720	90	300	M20x300
125	150	125	325	225	30	620	480	34	325	52k6	56	16	110	820	100	400	M24x400
150	200	150	400	248	35	750	570	34	400	60m6	64	18	135	1000	120	400	M30x400

NOTE: Pumps supplied with flanges according to EN 1092-2 as standard; available ASME B16.5 version on request.
For flanges dimensions see drawing on pages 92-93.

e-MPV-en_a_td

Size Number of stages	50		65		100		125		150	
	a	G1 [kg]	a	G1 [kg]	a	G1 [kg]	a	G1 [kg]	a	G1 [kg]
1	87	89	110	149	142	236	173	421	210	-
2	149	101	188	173	232	274	285	488	342	-
3	211	113	266	197	322	312	397	555	474	-
4	273	125	344	221	412	350	509	622	606	-
5	335	137	422	245	502	388	621	689	738	-
6	397	149	500	269	592	426	733	756	870	-
7	459	161	578	293	682	464	845	823		
8	521	173	656	317	772	502	957	890		
9	583	185	734	341	862	540				
10	645	197	812	365	952	578				
11	707	209	890	389	1042	616				
12	769	221	968	413						
13	831	233	1046	437						
14	893	245	1124	461						
15	955	257	1202	485						
16	1017	269								
17	1079	281								
18	1141	293								

e-MPV-stage-en_a_td

MPV SERIES DIMENSIONS AND WEIGHTS AT 50 Hz

PUMP TYPE	MPV	Size	3000 [rpm] [kW]	1500 [rpm] [kW]	Pump dimensions										Motor dimensions					
					50		65		100		125		150		h5	P	D	E	AD	G3 [kg]
					h4	G2 [kg]	h4	G2 [kg]	h4	G2 [kg]	h4	G2	h4	G2 [kg]						
100L	-	2,2	414	29,8	-	-	-	-	-	-	-	-	322	250	28 j6	60	168	29		
100L	-	3	414	29,8	-	-	-	-	-	-	-	-	353	250	28 j6	60	168	35,4		
112M	-	4	414	29,8	-	-	-	-	-	-	-	-	398	250	28 j6	60	168	57,2		
132S	5,5	-	434	32,1	-	-	-	-	-	-	-	-	375	300	38 k6	80	168	37,4		
132S	-	5,5	434	32,1	477	44,4	-	-	-	-	-	-	405	300	38 k6	80	191	62,8		
132S	7,5	-	434	32,1	-	-	-	-	-	-	-	-	367	300	38 k6	80	191	55,8		
132M	-	7,5	434	32,1	477	44,4	-	-	-	-	-	-	405	300	38 k6	80	191	67,4		
160M	11	-	464	38,2	-	-	-	-	-	-	-	-	428	350	42 k6	110	191	70,4		
160M	-	11	464	38,2	507	46,8	586	69,9	602	85,5	-	-	494	350	42 k6	110	240	86,2		
160M	15	-	464	38,2	507	46,8	-	-	-	-	-	-	494	350	42 k6	110	240	102		
160L	19	-	464	38,2	507	46,8	-	-	-	-	-	-	494	350	42 k6	110	240	110,6		
160L	-	15	464	39,3	507	47,9	586	69,9	602	85,5	-	-	494	350	42 k6	110	240	128,4		
180M	22	-	464	39,3	507	47,9	-	-	-	-	-	-	494	350	48k6	110	240	121,2		
180M	-	19	-	-	507	47,9	586	69,9	602	85,5	-	-	554	350	48k6	110	281	168		
180L	-	22	-	-	507	47,9	586	69,9	602	85,5	-	-	592	350	48k6	110	281	185		
200L	30	-	464	43,8	507	55,9	-	-	-	-	-	-	657	400	55m6	110	319	235		
200L	-	30	-	-	507	55,9	586	72	602	81,7	-	-	657	400	55m6	110	319	228		
200L	37	-	464	43,8	507	55,9	586	72	-	-	-	-	657	400	55m6	110	319	250		
225S/M	-	37	-	-	-	-	616	82,7	632	94,6	-	-	746	450	60m6	140	384	365		
225S/M	45	-	464	50,4	507	58,5	586	79,3	-	-	-	-	746	450	55m6	110	384	380		
225S/M	-	45	-	-	-	-	616	82,7	632	94,6	-	-	746	450	60m6	140	384	400		
250M	55	-	494	68,8	537	72,9	616	98,2	-	-	-	-	825	550	60m6	140	398	460		
250M	-	55	-	-	-	-	616	100,4	632	105,1	724	-	825	550	65m6	140	398	500		
280S/M	75	-	494	71	537	75,1	616	100,4	-	-	-	-	931	550	65m6	140	465	680		
280S/M	-	75	-	-	-	-	616	104,1	632	108,8	724	-	931	550	75m6	140	465	630		
280S/M	90	-	494	71	537	75,1	616	100,4	-	-	-	-	931	550	65m6	140	465	710		
280S/M	-	90	-	-	-	-	-	-	632	108,8	724	-	931	550	75m6	140	465	700		
315S/M	110	-	-	-	-	-	616	116	632	124,2	-	-	1104	660	65m6	140	530	900		
315S/M	132	-	-	-	-	-	616	116	632	124,2	-	-	1104	660	65m6	140	530	950		
315S/M	-	110	-	-	-	-	-	-	662	134,4	754	-	1104	660	80m6	170	530	950		
315S/M	-	132	-	-	-	-	-	-	-	-	754	-	1104	660	80m6	170	530	1010		
315S/M	160	-	-	-	-	-	616	116	632	124,2	-	-	1104	660	65m6	140	530	1080		
315L	200	-	-	-	-	-	616	119,7	632	127,9	724	-	1213	660	65m6	140	575	1200		
315L	250	-	-	-	-	-	616	119,7	632	127,9	724	-	1213	660	65m6	140	575	1350		
355M/L	315	-	-	-	-	-	-	-	632	157,4	724	-	1272	800	75m6	140	620	1950		
355M/L	355	-	-	-	-	-	-	-	632	157,4	724	-	1272	800	75m6	140	620	1950		
355A/B	400	-	-	-	-	-	-	-	632	164,5	724	-	1467	800	75m6	140	725	2250		
355A/B	450	-	-	-	-	-	-	-	632	164,5	724	-	1467	800	75m6	140	725	2400		

Total pump unit weight G = weight G1 + weight G2 + weight G3 (±5%)

e-MPV-AS-en_a_td

MPA SERIES FLANGE DIMENSIONS (EN1092-1, EN1092-2)

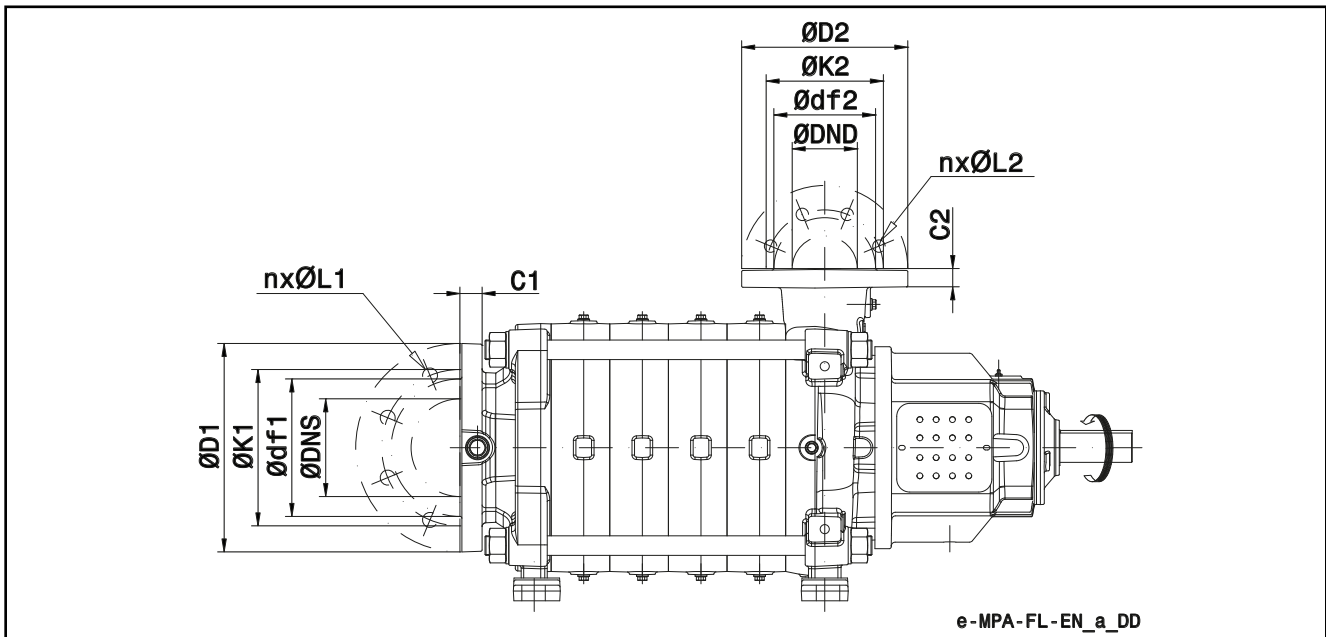

PUMP TYPE	DIMENSIONS (mm)															
	MPA	Suction side							Discharge side							
	Size	DNS	PN	D1	K1	C1	df1	n x ØL1	DND	PN	D2	K2	C2	df2	n x ØL2	
Cast Iron EN-GJL-250 (EN1092-2)	50	100	10/16	235	180	28	156	8x19	50	10/40	180	125	28	99	4x19	
	50	100	25/40	235	190	28	156	8x23	50							
	65	125	10/16	270	210	30	184	8x19	65	10/16	190	145	24	118	4x19	
	65	125	25/40	270	220	30	184	8x28	65	25/40	190	145	24	118	8x19	
	100	150	10/16	320	240	34	211	8x23	100	10/16	255	180	28	156	8x19	
	100	150	25/40	320	250	34	211	8x28	100	25/40	255	190	28	156	8x23	
	125	200	10	380	295	40	266	8x23	125	10/16	280	210	30	184	8x19	
	125	200	16	380	295	40	266	12x23	125	25/40	280	220	30	184	8x28	
	125	200	25	380	310	40	266	12x28								
	125	200	40	380	320	40	266	12x31								
	150	250	10	450	350	46	319	12x23	150	10/16	355	240	39	216	8x23	
	150	250	16	450	355	46	319	12x28	150	25/40	355	250	39	216	8x28	
150	250	25	450	370	46	330	12x31									
150	250	40	450	385	46	345	12x34									
Ductile Iron EN-GJS-400-15 (EN1092-2)	50	100	10/16	235	180	28	156	8x19	50	10/40	180	125	28	99	4x19	
	50	100	25/40	235	190	28	156	8x23	50	63	180	135	28	99	4x23	
	65	125	10/16	270	210	30	184	8x19	65	10/16	205	145	28	118	4x19	
	65	125	25/40	270	220	30	184	8x28	65	25/40	205	145	28	118	8x19	
									65	63	205	160	28	118	8x23	
	100	150	10/16	320	240	34	211	8x23	100	10/16	275	180	33	156	8x19	
	100	150	25/40	320	250	34	211	8x28	100	25/40	275	190	33	156	8x23	
	100								100	63	275	200	33	156	8x28	
	125	200	10	380	295	40	266	8x23	125	10/16	330	210	37	184	8x19	
	125	200	16	380	295	40	266	12x23	125	25/40	330	220	37	184	8x28	
	125	200	25	380	310	40	266	12x28	125	63	330	240	37	184	8x31	
	125	200	40	380	320	40	266	12x31								
150	250	10	450	350	46	319	12x23	150	10/16	355	240	39	216	8x23		
150	250	16	450	355	46	319	12x28	150	25/40	355	250	39	216	8x28		
150	250	25	450	370	46	330	12x31	150	63	355	280	39	216	8x34		
150	250	40	450	385	46	345	12x34									
Cast Steel 1.4408, 1.4517 (EN1092-1)	50	100	10/16	235	180	24	160	8x18	50	10/40	180	125	26	102	4x18	
	50	100	25/40	235	190	24	160	8x22	50	63	180	135	26	102	4x22	
	65	125	10/16	270	210	26	188	8x18	65	10/16	205	145	26	122	4x18	
	65	125	25/40	270	220	26	188	8x26	65	25/40	205	145	26	122	8x18	
	65								65	63	205	160	26	122	8x22	
	100	150	10/16	320	240	28	216	8x22	100	10/16	275	180	30	162	8x18	
	100	150	25/40	320	250	28	216	8x26	100	25/40	275	190	30	162	8x22	
	100								100	63	275	200	30	162	8x26	
	125	200	10	380	295	34	268	8x22	125	10/16	330	210	34	188	8x18	
	125	200	16	380	295	34	268	12x22	125	25/40	330	220	34	188	8x26	
	125	200	25	380	310	34	278	12x26	125	63	330	240	34	188	8x30	
	125	200	40	380	320	34	285	12x30								
	150	250	10	450	350	38	320	12x22	150	10/16	355	240	36	216	8x22	
	150	250	16	450	355	38	320	12x26	150	25/40	355	250	36	216	8x26	
	150	250	25	450	370	38	335	12x30	150	63	355	280	36	216	8x33	
150	250	40	450	385	38	345	12x33									

NOTE: Value D, C and df may vary from standard

e-MPA-FL-EN-en_a_td

MPA SERIES FLANGE DIMENSIONS (ASME B16.5)

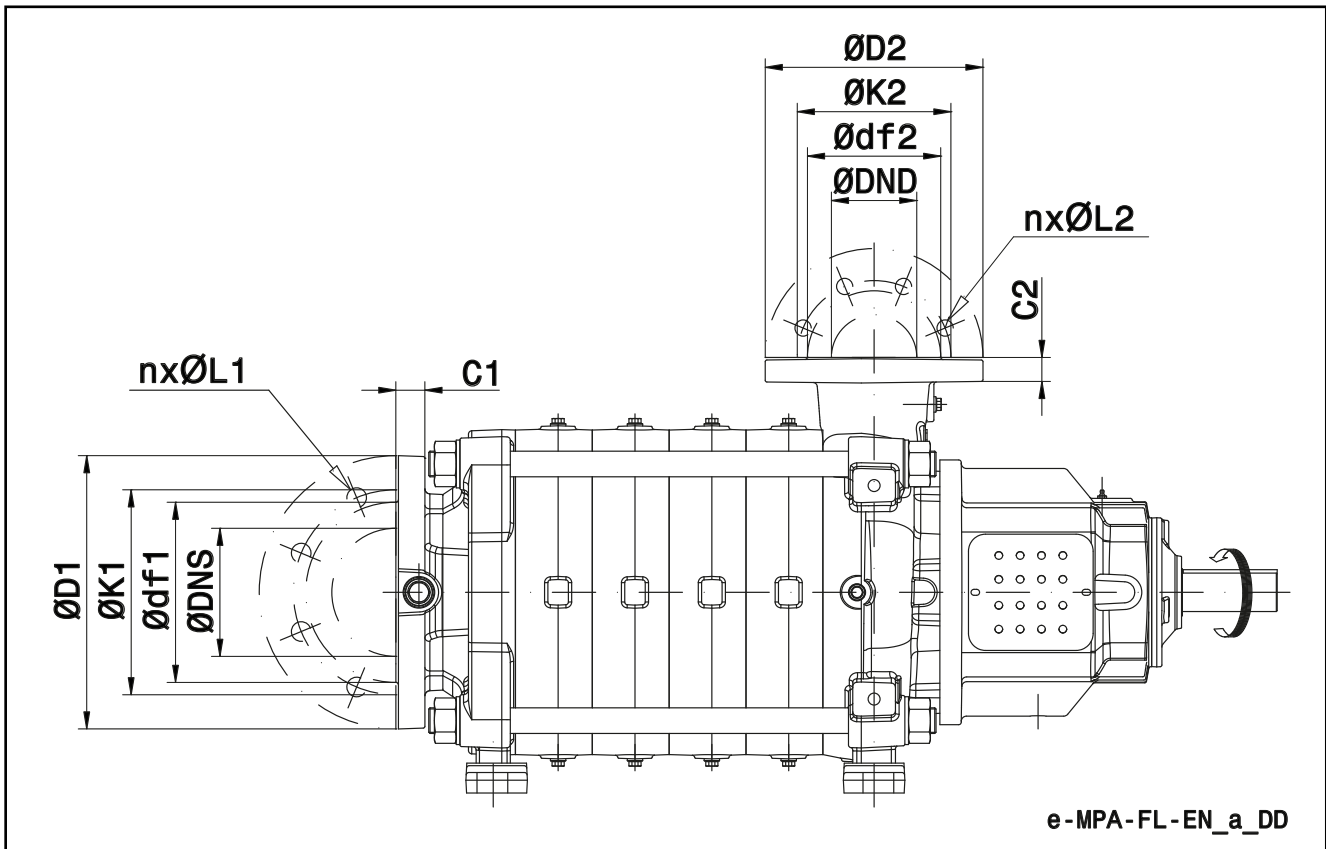

PUMP TYPE	DIMENSIONS (mm)														
	MPA Size	Suction side							Discharge side						
		DNS	CLASS	D1	K1	C1	df1	n x ØL1	DND	CLASS	D2	K2	C2	df2	n x ØL2
Cast Iron EN-GJL-250 (ASME B16.5)	50	4"	150	235	190,5	28	156	8x18	2"	150	180	120,5	28	99	4x18
	50								2"	300	180	127	28	99	8x18
	65	5"	150	270	216	30	184	8x22	2 1/2"	150	190	139,5	24	118	4x18
	65								2 1/2"	300	190	149,5	24	118	8x22
	100	6"	150	320	241,5	34	211	8x22	4"	150	255	190,5	28	156	8x18
	100	6"	300	320	270	34	211	12xM20	4"	300	255	200	28	156	8x22
	125	8"	150	380	298,5	40	266	8x22	5"	150	280	216	30	184	8x22
	125	8"	300	380	330	40	266	12x26	5"	300	280	235	30	184	8x22
	150	10"	150	450	362	46	324	12x26	6"	150	355	241,5	39	216	8x22
150	10"	300	450	387,5	46	324	16x29,5	6"	300	355	270	39	216	12x22	
Ductile Iron EN-GJS-400-15 (ASME B16.5)	50	4"	150	235	190,5	28	156	8x18	2"	150	180	120,5	28	99	4x18
	50								2"	300/600	180	127	28	99	8x18
	65	5"	150	270	216	30	184	8x22	2 1/2"	150	205	139,5	28	118	4x18
	65								2 1/2"	300/600	205	149,5	28	118	8x22
	100	6"	150	320	241,5	34	211	8x22	4"	150	275	190,5	33	156	8x18
	100	6"	300	320	270	34	211	12xM20	4"	300	275	200	33	156	8x22
	100								4"	600	275	216	33	156	8x26
	125	8"	150	380	298,5	40	266	8x22	5"	150	330	216	37	184	8x22
	125	8"	300	380	330	40	266	12x26	5"	300	330	235	37	184	8x22
	125								5"	600	330	267	37	184	8x29,5
	150	10"	150	450	362	46	324	12x26	6"	150	355	241,5	39	216	8x22
150	10"	300	450	387,5	46	324	16x29,5	6"	300	355	270	39	216	12x22	
Cast Steel 1.4408, 1.4517 (ASME B16.5)	50	4"	150	235	190,5	24	160	8x18	2"	150	180	120,5	26	102	4x18
	50								2"	300	180	127	26	102	8x18
	65	5"	150	270	216	26	188	8x22	2 1/2"	150	205	139,5	26	122	4x18
	65								2 1/2"	300/600	205	149,5	26	122	8x22
	100	6"	150	320	241,5	28	216	8x22	4"	150	275	190,5	30	162	8x18
	100	6"	300	320	270	28	216	12xM20	4"	300	275	200	30	162	8x22
	100								4"	600	275	216	30	162	8x26
	125	8"	150	380	298,5	34	270	8x22	5"	150	330	216	34	188	8x22
	125	8"	300	380	330	34	270	12x26	5"	300	330	235	34	188	8x22
	125								5"	600	330	267	34	188	8x29,5
	150	10"	150	450	362	38	324	12x26	6"	150	355	241,5	36	216	8x22
150	10"	300	450	387,5	38	324	16x29,5	6"	300	355	270	36	216	12x22	
150								6"	600	355	292	36	216	12x29,5	

NOTE: Value D, C and df may vary from standard

e-MPA-FL-ASME-en_a_id

MPD, MPR, MPV SERIES FLANGE DIMENSIONS (EN1092-1, EN1092-2)

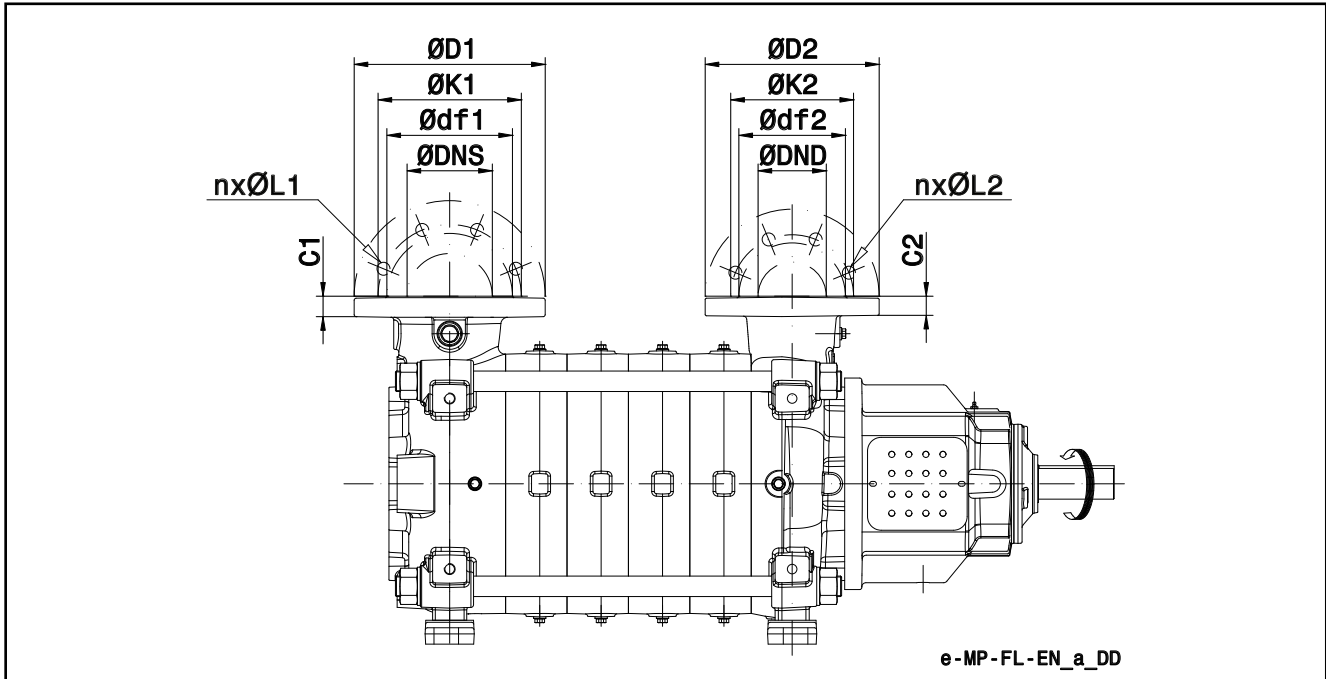

e-MP-FL-EN_a_DD

PUMP TYPE	DIMENSIONS (mm)														
	MPD, MPR, MPV	Suction side							Discharge side						
		Size	DNS	PN	D1	K1	C1	df1	n x ØL1	DND	PN	D2	K2	C2	df2
Cast Iron EN-GIL-250 (EN1092-2)	50	80	10/40	210	160	26	132	8x19	50	10/40	180	125	28	99	4x19
	65	100	10/16	255	180	28	156	8x19	65	10/16	190	145	24	118	4x19
	65	100	25/40	255	190	28	156	8x23	65	25/40	190	145	24	118	8x19
	100	125	10/16	280	210	30	184	8x19	100	10/16	255	180	28	156	8x19
	100	125	25/40	280	220	30	184	8x28	100	25/40	255	190	28	156	8x23
	125	150	10/16	320	240	34	216	8x23	125	10/16	280	210	30	184	8x19
	125	150	25/40	320	250	34	216	8x28	125	25/40	280	220	30	184	8x28
	150	200	10	380	295	40	266	8x23	150	10/16	355	240	39	216	8x23
	150	200	16	380	295	40	266	12x23	150	25/40	355	250	39	216	8x28
	150	200	25	380	310	40	274	12x28							
150	200	40	380	320	40	284	12x31								
Ductile Iron EN-GIS-400-15 (EN1092-2)	50	80	10/40	210	160	26	132	8x19	50	10/40	180	125	28	99	4x19
	50								50	63	180	135	28	99	4x23
	65	100	10/16	255	180	28	156	8x19	65	10/16	205	145	28	118	4x19
	65	100	25/40	255	190	28	156	8x23	65	25/40	205	145	28	118	8x19
	65								65	63	205	160	28	118	8x23
	100	125	10/16	280	210	30	184	8x19	100	10/16	275	180	33	156	8x19
	100	125	25/40	280	220	30	184	8x28	100	25/40	275	190	33	156	8x23
	100								100	63	275	200	33	156	8x28
	125	150	10/16	320	240	34	216	8x23	125	10/16	330	210	37	184	8x19
	125	150	25/40	320	250	34	216	8x28	125	25/40	330	220	37	184	8x28
	125								125	63	330	240	37	184	8x31
	150	200	10	380	295	40	266	8x23	150	10/16	355	240	39	216	8x23
	150	200	16	380	295	40	266	12x23	150	25/40	355	250	39	216	8x28
	150	200	25	380	310	40	274	12x28	150	63	355	280	39	216	8x34
150	200	40	380	320	40	284	12x31								
Cast Steel T.4408, T.4517 (EN1092-1)	50	80	10/40	210	160	24	138	8x18	50	10/40	180	125	26	102	4x18
	50								50	63	180	135	26	102	4x22
	65	100	10/16	255	180	24	158	8x18	65	10/16	205	145	26	122	4x18
	65	100	25/40	255	190	24	158	8x22	65	25/40	205	145	26	122	8x18
	65								65	63	205	160	26	122	8x22
	100	125	10/16	280	210	26	188	8x18	100	10/16	275	180	30	162	8x18
	100	125	25/40	280	220	26	188	8x26	100	25/40	275	190	30	162	8x22
	100								100	63	275	200	30	162	8x26
	125	150	10/16	320	240	28	212	8x22	125	10/16	330	210	34	188	8x18
	125	150	25/40	320	250	28	212	8x26	125	25/40	330	220	34	188	8x26
	125								125	63	330	240	34	188	8x30
	150	200	10	380	295	34	268	8x22	150	10/16	355	240	36	216	8x22
	150	200	16	380	295	34	268	12x22	150	25/40	355	250	36	216	8x26
	150	200	25	380	310	34	278	12x26	150	63	355	280	36	216	8x33
	150	200	40	380	320	34	285	12x30							

NOTE: Value D, C and df may vary from standard

e-MP-FL-EN-en_a_td

MPD, MPR, MPV SERIES FLANGE DIMENSIONS (ASME B16.5)

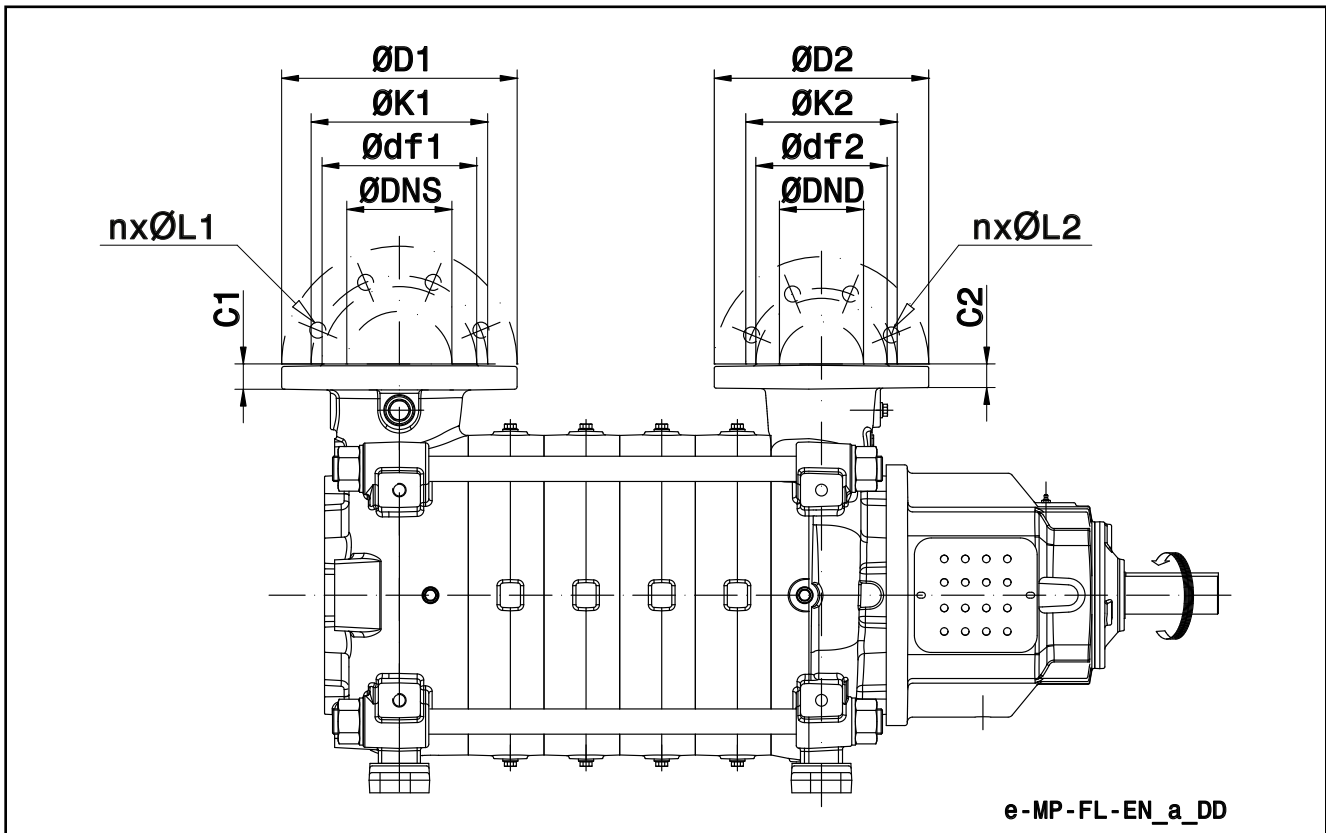

e-MP-FL-EN_a_DD

PUMP TYPE	DIMENSIONS (mm)														
	MPD, MPR, MPV	Suction side							Discharge side						
		Size	DNS	CLASS	D1	K1	C1	df1	n x ØL1	DND	CLASS	D2	K2	C2	df2
Cast Iron EN-GJS-250 (ASME B16.5)	50	3"	150	210	152,5	26	132	4x18	2"	150	180	120,5	28	99	4x18
	50	3"	300	210	168	26	132	8x22	2"	300	180	127	28	99	8x18
	65	4"	150	255	190,5	28	156	8x18	2 1/2"	150	190	139,5	24	118	4x18
	65	4"	300	255	200	28	156	8x22	2 1/2"	300	190	149,5	24	118	8x22
	100	5"	150	280	216	30	184	8x22	4"	150	255	190,5	28	156	8x18
	100	5"	300	280	235	30	184	8x22	4"	300	255	200	28	156	8x22
	125	6"	150	320	241,5	34	216	8x22	5"	150	280	216	30	184	8x22
	125	6"	300	320	270	34	216	12x22	5"	300	280	235	30	184	8x22
	150	8"	150	380	298,5	40	270	8x22	6"	150	355	241,5	39	216	8x22
150	8"	300	380	330	40	270	12x26	6"	300	355	270	39	216	12x22	
Ductile Iron EN-GJS-400-15 (ASME B16.5)	50	3"	150	210	152,5	26	132	4x18	2"	150	180	120,5	28	99	4x18
	50	3"	300	210	168	26	132	8x22	2"	300/600	180	127	28	99	8x18
	65	4"	150	255	190,5	28	156	8x18	2 1/2"	150	205	139,5	28	118	4x18
	65	4"	300	255	200	28	156	8x22	2 1/2"	300/600	205	149,5	28	118	8x22
	100	5"	150	280	216	30	184	8x22	4"	150	275	190,5	33	156	8x18
	100	5"	300	280	235	30	184	8x22	4"	300	275	200	33	156	8x22
	100								4"	600	275	216	33	156	8x26
	125	6"	150	320	241,5	34	216	8x22	5"	150	330	216	37	184	8x22
	125	6"	300	320	270	34	216	12x22	5"	300	330	235	37	184	8x22
	125								5"	600	330	267	37	184	8x29,5
	150	8"	150	380	298,5	40	270	8x22	6"	150	355	241,5	39	216	8x22
	150	8"	300	380	330	40	270	12x26	6"	300	355	270	39	216	12x22
150								6"	600	355	292	39	216	12x29,5	
Cast Steel 1.4408, 1.4517 (ASME B16.5)	50	3"	150	210	152,5	24	138	4x18	2"	150	180	120,5	26	102	4x18
	50	3"	300	210	168	24	138	8x22	2"	300	180	127	26	102	8x18
	65	4"	150	255	190,5	24	158	8x18	2 1/2"	150	205	139,5	26	122	4x18
	65	4"	300	255	200	24	158	8x22	2 1/2"	300/600	205	149,5	26	122	8x22
	100	5"	150	280	216	26	188	8x22	4"	150	275	190,5	30	162	8x18
	100	5"	300	280	235	26	188	8x22	4"	300	275	200	30	162	8x22
	100								4"	600	275	216	30	162	8x26
	125	6"	150	320	241,5	28	212	8x22	5"	150	330	216	34	188	8x22
	125	6"	300	320	270	28	212	12x22	5"	300	330	235	34	188	8x22
	125								5"	600	330	267	34	188	8x29,5
	150	8"	150	380	298,5	34	270	8x22	6"	150	355	241,5	36	216	8x22
	150	8"	300	380	330	34	270	12x26	6"	300	355	270	36	216	12x22
150								6"	600	355	292	36	216	12x29,5	

NOTE: Value D, C and df may vary from standard

**e-MP
with
HYDROVAR®
(HVL series)**

MP.H SERIES (e-MP WITH HYDROVAR)

Background and context

For all pumping needs in commercial or residential building and in industry applications, the demand for intelligent pumping systems is constantly growing. Controlled systems offer many advantages: reduced operating costs for the lifetime of the pump, lower environmental impact, longer lifetime of piping systems and networks.

For this reason, Lowara has developed the MP.H: an intelligent pumping system which assures high level performance with energy consumption tailored to the system's demand.

Benefits of e-MP with HYDROVAR

Saving: MP.H transforms the e-MP pumps into variable speed intelligent pumping systems. Thanks to the HYDROVAR, the speed of each pump varies so as to maintain a constant flow, a constant pressure, or a differential pressure. In doing so, at any point in time, the pump only receives the energy required. This in turns allows for considerable savings, especially for systems that have varying loads throughout the day.

Easy installation and space-saving: MP.H saves time and space during installation. The Hydrovar is delivered already mounted on the motor (for models up to 22kW). The hydrovar is kept cool by the motor fan and does not require a control panel. In order to function, only fuses on the supply line are needed (Check your local electrical installation regulations).

Key Features of the HYDROVAR

- **No need for additional pressure sensors:**
The MP.H is fitted as standard with two pressure transmitters, normally fitted on the flanges.
- **No need for special pumps or motors.**
- **MP.H is already pre-wired.**
- **No need for IN LINE filters.**
HYDROVAR already includes the THDi filter embedded as standard.
- **No need for bypass or safety systems:**
The MP.H will immediately switch off when demand drops to zero or when it exceeds maximum pump capacity; thus making installation of additional safety devices unnecessary.
- **Anti-condensation device:**
The HYDROVAR is fitted with anti-condensation devices which switch on when the pump is in standby in order to prevent condensation forming in the unit.

HYDROVAR HVL: 1,5 kW to 22 kW, can be mounted to motor or wall

HYDROVAR SMART: Over 22 kW, combines all HYDROVAR intelligence with any frequency drive, and can be installed anywhere due to its slim design (e.g. inside of the control panel)

Features	HYDROVAR HVL	HYDROVAR SMART
Fits onto any standard asynchronous motor	•	-
Advanced motor control	•	•
THDi filter embedded	•	on request
Extended communication capabilities	•	•
Easy to commission and operate	•	•
Multi-pump capability	up to 8	up to 4

MP..H SERIES (e-MP WITH HYDROVAR)

The basic function of the HYDROVAR device is to control the pump to meet the system demands.

HYDROVAR performs these functions by:

- 1) Measuring the system pressure or flow via a transmitter mounted on the pump's delivery side.
- 2) Calculating the motor speed to maintain the correct flow or pressure.
- 3) Sending out a signal to the pump to start the motor, increase speed, decrease speed or stop.
- 4) In the case of multiple pump installations, HYDROVAR will automatically provide for the cyclic changeover of the pumps' starting sequence.

In addition to these basic functions, HYDROVAR can perform controls only manageable by the most advanced computerized control systems. Some examples are:

- Stop the pump(s) at zero demand.
- Stop the pump(s) in case of water failure on the suction side (protection against dry running).
- Stop the pump if the required delivery exceeds the pump's capacity (protection against cavitation caused by excessive demand), or automatically switch on the next pump in a multiple series.
- Protect the pump and motor from over-voltage, under-voltage, overload, and earth fault.
- Vary the pump speed: acceleration and deceleration time.
- Compensate for increased flow resistance at high flow rates.
- Conduct automatic tests at set intervals.
- Monitor the converter and motor operating hours.
- Display the energy consumption (kWh).
- Display all functions on an LCD in different languages (Italian, English, French, German, Spanish, Portuguese, Dutch, etc...).
- Send a signal to a remote control system which is proportional to the pressure and frequency.
- Communicate with external control system via Modbus (RS 485 interface) and Bacnet as standard.

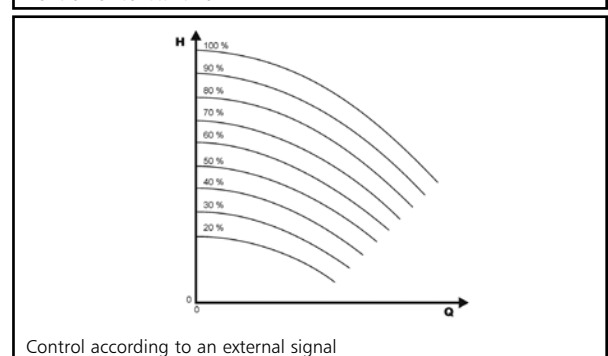
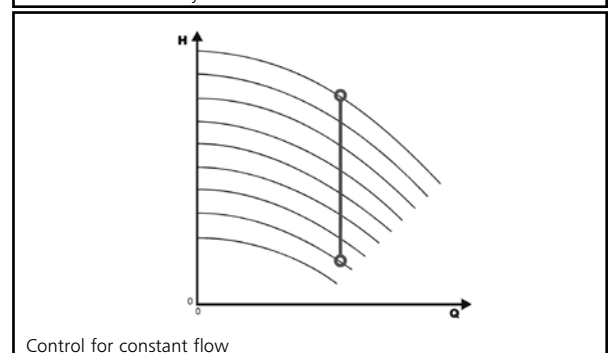
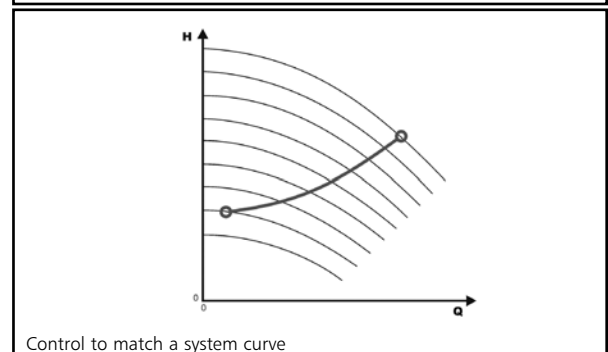
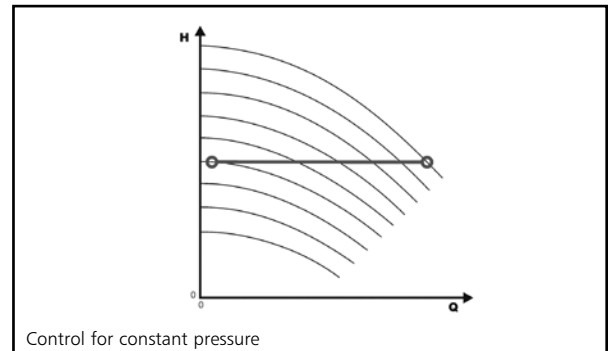

HYDROVAR HVL IDENTIFICATION CODE

H V L 4 . 0 7 5 - A 0 0 1 0

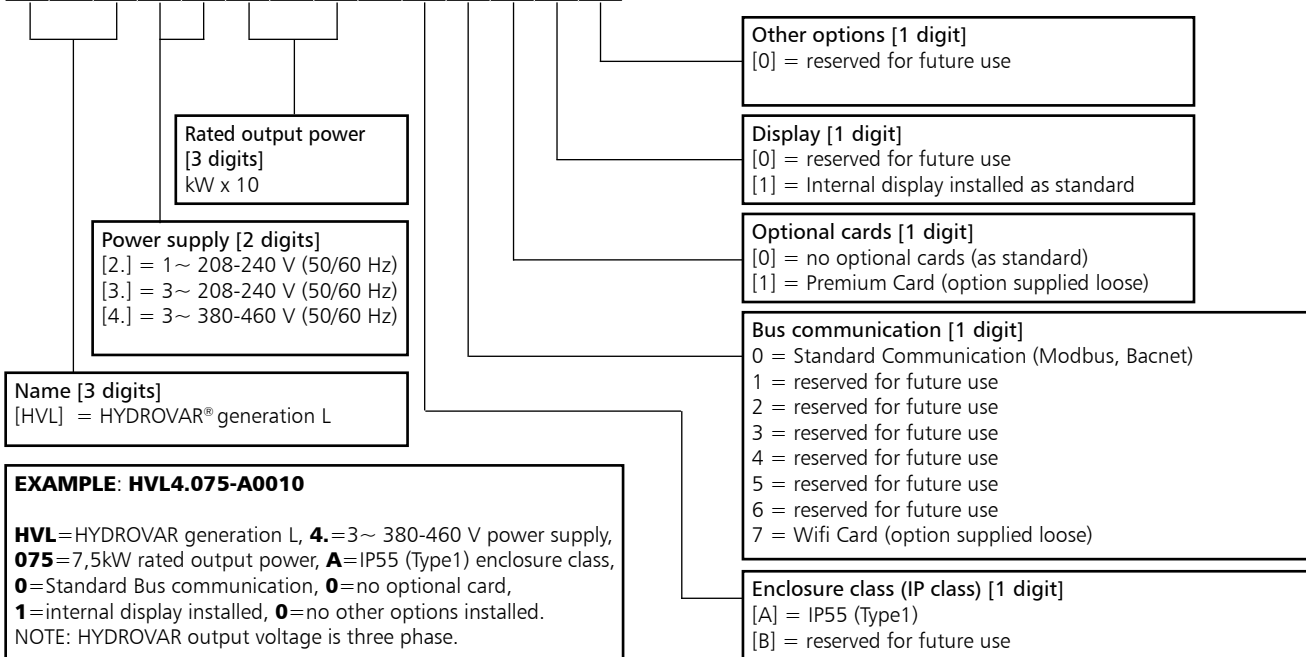

DIMENSIONS AND WEIGHTS



TYPE	MODELS			DIMENSIONS (mm)				WEIGHT Kg
	/2	/3	/4	L	B	H	X	
SIZE A	HVL2.015 ÷ 2.022	HVL3.015 ÷ 3.022	HVL4.015 ÷ 4.040	216	205	170	243	5,6
SIZE B	HVL2.030 ÷ 2.040	HVL3.030 ÷ 3.055	HVL4.055 ÷ 4.110	276	265	185	305	10,5
SIZE C	-	HVL3.075 ÷ 3.110	HVL4.150 ÷ 4.220	366	337	200	407	15,6

HVL_dim-en_b_td

HYDROVAR HVL EMC COMPATIBILITY

EMC requirements

HYDROVAR fulfills the product standard EN61800-3:2004 + A1:2012, which defines categories (C1 to C4) for device application areas.

Depending on the motor cable length, a classification of HYDROVAR by category (based on EN61800-3) is reported in the following tables:

HVL	HYDROVAR classification by categories based on EN61800-3
2.015 ÷ 2.040	C1 (*)
3.015 ÷ 3.110	C2 (*)
4.015 ÷ 4.220	C2 (*)

(*) 0,75 motor cable length; contact Xylem for further information

En-Rev_A

CARD

Premium Card HYDROVAR (optional)

For the e-MPH series, the Premium Card comes fitted as option on the standalone HYDROVAR.

This allows to control up to five fix speed pumps via an external panel.

The Premium Card will allow additional features listed below:

- 2 additional Analog Inputs
- 2 Analog Outputs
- 1 additional digital input
- 5 relays.

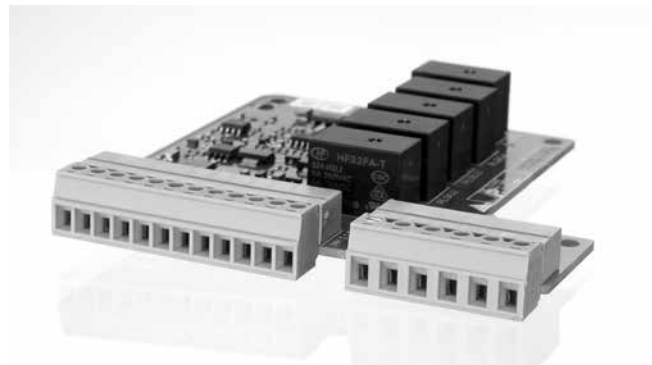

Wi-Fi Card HYDROVAR (optional)

With the WiFi card fitted in the HYDROVAR, the unit can will allow you to be connected to a wireless network.

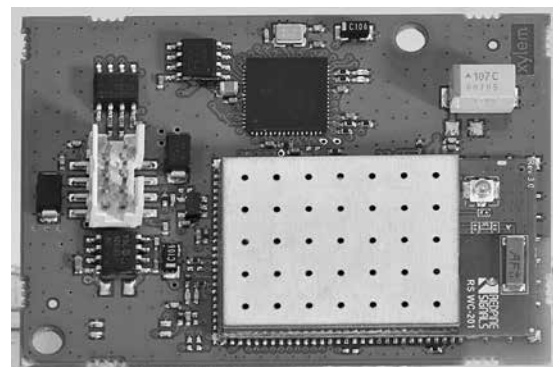

OPTIONAL COMPONENTS

Sensors

The following sensors are available for HYDROVAR:

- Pressure-transducer
- Differential pressure-transducer
- Temperature-sensor
- Flow indicator (orifice plate, inductive flow meter)
- Level-sensor.

HYDROVAR HVL (WALL MOUNTING KIT) DIMENSIONS AND WEIGHTS

As an option a HYDROVAR wall mounting kit is also available. This is used where mounting on the pump unit is impossible or where you would like the controls in another location. These are available for the new generation HYDROVAR HVL 2.015-4.220 (22 kW). The speed of the cooling fan modulates with the HYDROVAR usage which optimizes energy consumption and also reduces noise.

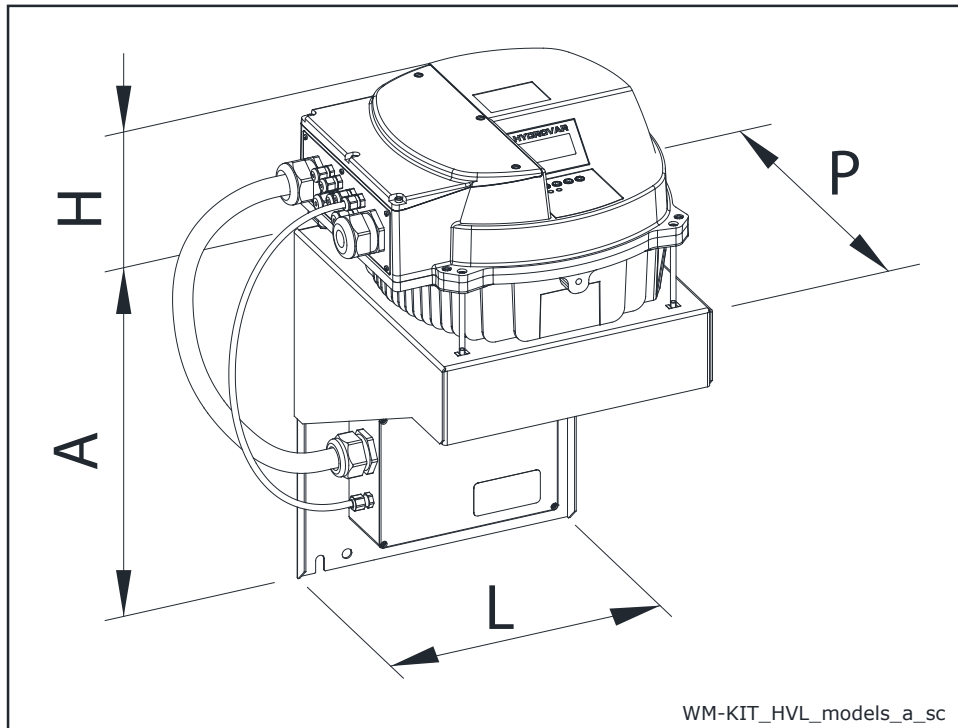

WM KIT TYPE	kW	WM KIT POWER SUPPLY	HVL SIZE	DIMENSIONS (mm)				WEIGHT (kg)	
				A	H	L	P	HVL	WM KIT
WM KIT HVL 2.015	1,5	1~ 230V	A	220	170	202	232	5,6	2,6
WM KIT HVL 2.022	2,2			220	170	202	232	5,6	2,6
WM KIT HVL 2.030	3		B	240	175	258	290	10,5	8,2
WM KIT HVL 2.040	4			320	175	288	305	10,5	5,4
WM KIT HVL 3.015	1,5	3~ 230V	A	220	170	202	232	5,6	2,6
WM KIT HVL 3.022	2,2			220	170	202	232	5,6	2,6
WM KIT HVL 3.030	3		B	240	175	258	290	10,5	8,2
WM KIT HVL 3.040	4			240	175	258	290	10,5	8,2
WM KIT HVL 3.055	5,5		C	240	175	258	290	10,5	8,2
WM KIT HVL 3.075	7,5			400	200	325	365	15,6	11,6
WM KIT HVL 3.110	11		400	200	325	365	15,6	11,6	
WM KIT HVL 4.015	1,5		3~ 400V	A	240	170	258	290	5,6
WM KIT HVL 4.022	2,2	240			170	258	290	5,6	8,2
WM KIT HVL 4.030	3	240			170	258	290	5,6	8,2
WM KIT HVL 4.040	4	240			170	258	290	5,6	8,2
WM KIT HVL 4.055	5,5	B		240	175	258	290	10,5	8,2
WM KIT HVL 4.075	7,5			240	175	258	290	10,5	8,2
WM KIT HVL 4.110	11	C		320	175	288	305	10,5	5,4
WM KIT HVL 4.150	15			400	200	325	365	15,6	11,6
WM KIT HVL 4.185	18,5			400	200	325	365	15,6	11,6
WM KIT HVL 4.220	22			400	200	325	365	15,6	11,6

WM-KIT_HVL_models-EN_b_td

ACCESSORIES

SPACER COUPLING DIMENSIONS

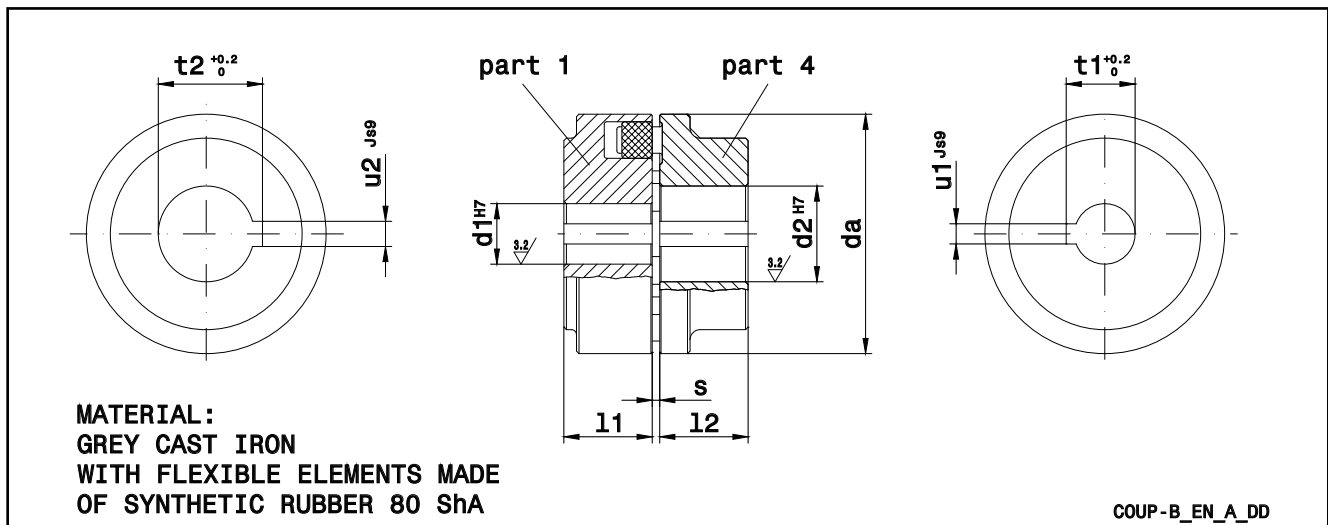

REF.	DENOMINATION	DIMENSIONS (mm)									
		SIZE x d ₁ x d ₂	d _a	PART 1 PUMP-SIDE HALF COUPLING				PART 4 MOTOR-SIDE HALF COUPLING			
				d ₁ ^{H7}	l ₁	u ₁ ^{js9}	t ₁ ^{+0.2, 0}	s	d ₂ ^{H7}	l ₂	u ₂ ^{js9}
B80A	B 80 x 28 x 28	80	28	30	8	31.3	2÷4	28	30	8	31.3
B80B	B 80 x 28 x 38	80	28	30	8	31.3	2÷4	38	30	10	41.3
B95A	B 95 x 28 x 42	95	28	35	8	31.3	2÷4	42	35	12	45.3
B95B	B 95 x 35 x 28	95	35	35	10	38.3	2÷4	28	35	8	31.3
B95C	B 95 x 35 x 38	95	35	35	10	38.3	2÷4	38	35	10	41.3
B95D	B 95 x 35 x 42	95	35	35	10	38.3	2÷4	42	35	12	45.3
B110A	B 110 x 28 x 42	110	28	40	8	31.3	2÷4	42	40	12	45.3
B110B	B 110 x 28 x 48	110	28	40	8	31.3	2÷4	48	40	14	51.8
B110C	B 110 x 35 x 42	110	35	40	10	38.3	2÷4	42	40	12	45.3
B110D	B 110 x 35 x 48	110	35	40	10	38.3	2÷4	48	40	14	51.8
B110E	B 110 x 45 x 38	110	45	40	14	48.8	2÷4	38	40	10	41.3
B110F	B 110 x 45 x 42	110	45	40	14	48.8	2÷4	42	40	12	45.3
B110G	B 110 x 45 x 48	110	45	40	14	48.8	2÷4	48	40	14	51.8
B125A	B 125 x 28 x 55	125	28	50	8	31.3	2÷4	55	50	16	59.3
B125B	B 125 x 35 x 55	125	35	50	10	38.3	2÷4	55	50	16	59.3
B125C	B 125 x 45 x 55	125	45	50	14	48.8	2÷4	55	50	16	59.3
B125D	B 125 x 52 x 42	125	52	50	16	56.3	2÷4	42	50	12	45.3
B125E	B 125 x 52 x 48	125	52	50	16	56.3	2÷4	48	50	14	51.8
B125F	B 125 x 52 x 55	125	52	50	16	56.3	2÷4	55	50	16	59.3
B140A	B 140 x 28 x 60	140	28	55	8	31.3	2÷4	60	55	18	64.4
B140B	B 140 x 35 x 60	140	35	55	10	38.3	2÷4	60	55	18	64.4
B140C	B 140 x 45 x 60	140	45	55	14	48.8	2÷4	60	55	18	64.4
B140D	B 140 x 52 x 60	140	52	55	16	56.3	2÷4	60	55	18	64.4
B160A	B 160 x 28 x 65	160	28	60	8	31.3	2÷6	65	60	18	69.4
B160B	B 160 x 35 x 65	160	35	60	10	38.3	2÷6	65	60	18	69.4
B160C	B 160 x 45 x 65	160	45	60	14	48.8	2÷6	65	60	18	69.4
B160D	B 160 x 52 x 65	160	52	60	16	56.3	2÷6	65	60	18	69.4
B180A	B 180 x 28 x 65	180	28	70	8	31.3	2÷6	65	70	18	69.4
B180B	B 180 x 35 x 65	180	35	70	10	38.3	2÷6	65	70	18	69.4
B180C	B 180 x 35 x 75	180	35	70	10	38.3	2÷6	75	70	20	79.9
B180D	B 180 x 45 x 65	180	45	70	14	48.8	2÷6	65	70	18	69.4
B180E	B 180 x 45 x 75	180	45	70	14	48.8	2÷6	75	70	20	79.9
B180F	B 180 x 52 x 65	180	52	70	16	56.3	2÷6	65	70	18	69.4
B180G	B 180 x 52 x 75	180	52	70	16	56.3	2÷6	75	70	20	79.9
B200A	B 200 x 35 x 75	200	35	80	10	38.3	2÷6	75	80	20	79.9
B200B	B 200 x 45 x 75	200	45	80	14	48.8	2÷6	75	80	20	79.9
B200C	B 200 x 45 x 80	200	45	80	14	48.8	2÷6	80	80	22	85.4
B200D	B 200 x 52 x 75	200	52	80	16	56.3	2÷6	75	80	20	79.9
B200E	B 200 x 52 x 80	200	52	80	16	56.3	2÷6	80	80	22	85.4
B225A	B 225 x 45 x 75	225	45	90	14	48.8	2÷6	75	90	20	79.9
B225B	B 225 x 45 x 80	225	45	90	14	48.8	2÷6	80	90	22	85.4
B225C	B 225 x 52 x 75	225	52	90	16	56.3	2÷6	75	90	20	79.9
B225D	B 225 x 52 x 80	225	52	90	16	56.3	2÷6	80	90	22	85.4

FLEXIBLE COUPLING DIMENSIONS

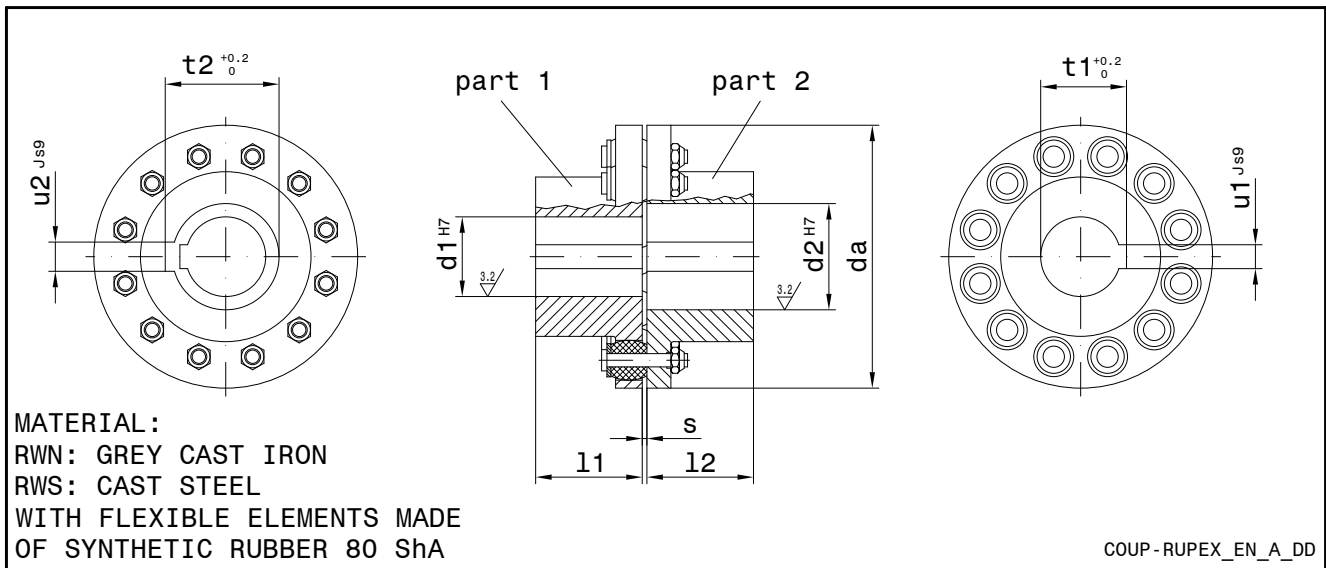

REF.	DENOMINATION	DIMENSIONS (mm)									
		d _a	PART 1 PUMP-SIDE HALF COUPLING				PART 2 MOTOR-SIDE HALF COUPLING				
			d ₁ ^{H7}	l ₁	u ₁ ^{js9}	t _{1 0} ^{+0.2}	s	d ₂ ^{H7}	l ₂	u ₂ ^{js9}	t _{2 0} ^{+0.2}
SIZE x d ₁ x d ₂											
RWN198A	RWN 198 x 35 x 75	198	35	80	10	38,3	3,5	75	80	20	79,9
RWN198B	RWN 198 x 45 x 75	198	45	80	14	48,8	3,5	75	80	20	79,9
RWN198C	RWN 198 x 52 x 75	198	52	80	16	56,3	3,5	75	80	20	79,9
RWN252A	RWN 252 x 45 x 80	252	45	100	14	48,8	3,5	80	100	22	85,4
RWN252B	RWN 252 x 52 x 80	252	52	100	16	56,3	3,5	80	100	22	85,4
RWN252C	RWN 252 x 52 x 85	252	52	100	16	56,3	3,5	85	100	22	90,4
RWS198A	RWS 198 x 35 x 65	198	35	80	10	38,3	3,5	65	80	18	69,4
RWS198B	RWS 198 x 35 x 75	198	35	80	10	38,3	3,5	75	80	20	79,9
RWS198C	RWS 198 x 45 x 65	198	45	80	14	48,8	3,5	65	80	18	69,4
RWS198D	RWS 198 x 45 x 75	198	45	80	14	48,8	3,5	75	80	20	79,9
RWS198E	RWS 198 x 52 x 65	198	52	80	16	56,3	3,5	65	80	18	69,4
RWS198F	RWS 198 x 52 x 75	198	52	80	16	56,3	3,5	75	80	20	79,9
RWS228A	RWS 228 x 45 x 75	228	45	90	14	48,8	3,5	75	90	20	79,9
RWS228B	RWS 228 x 45 x 80	228	45	90	14	48,8	3,5	80	90	22	85,4
RWS228C	RWS 228 x 52 x 75	228	52	90	16	56,3	3,5	75	90	20	79,9
RWS228D	RWS 228 x 52 x 80	228	52	90	16	56,3	3,5	80	90	22	85,4
RWS228E	RWS 228 x 52 x 85	228	52	90	16	56,3	3,5	85	90	22	90,4
RWS252A	RWS 252 x 45 x 80	252	45	100	14	48,8	3,5	80	100	22	85,4
RWS252B	RWS 252 x 52 x 80	252	52	100	16	56,3	3,5	80	100	22	85,4
RWS252C	RWS 252 x 52 x 85	252	52	100	16	56,3	3,5	85	100	22	90,4
RWS285A	RWS 285 x 52 x 80	285	52	110	16	56,3	4,5	80	110	22	85,4
RWS285B	RWS 285 x 52 x 85	285	52	110	16	56,3	4,5	85	110	22	90,4

Coup-RUPEX_en_a_td

SENSOR CONNECTOR AND SENSORS FOR PUMP-MONITORING AND DIAGNOSTIC SYSTEMS

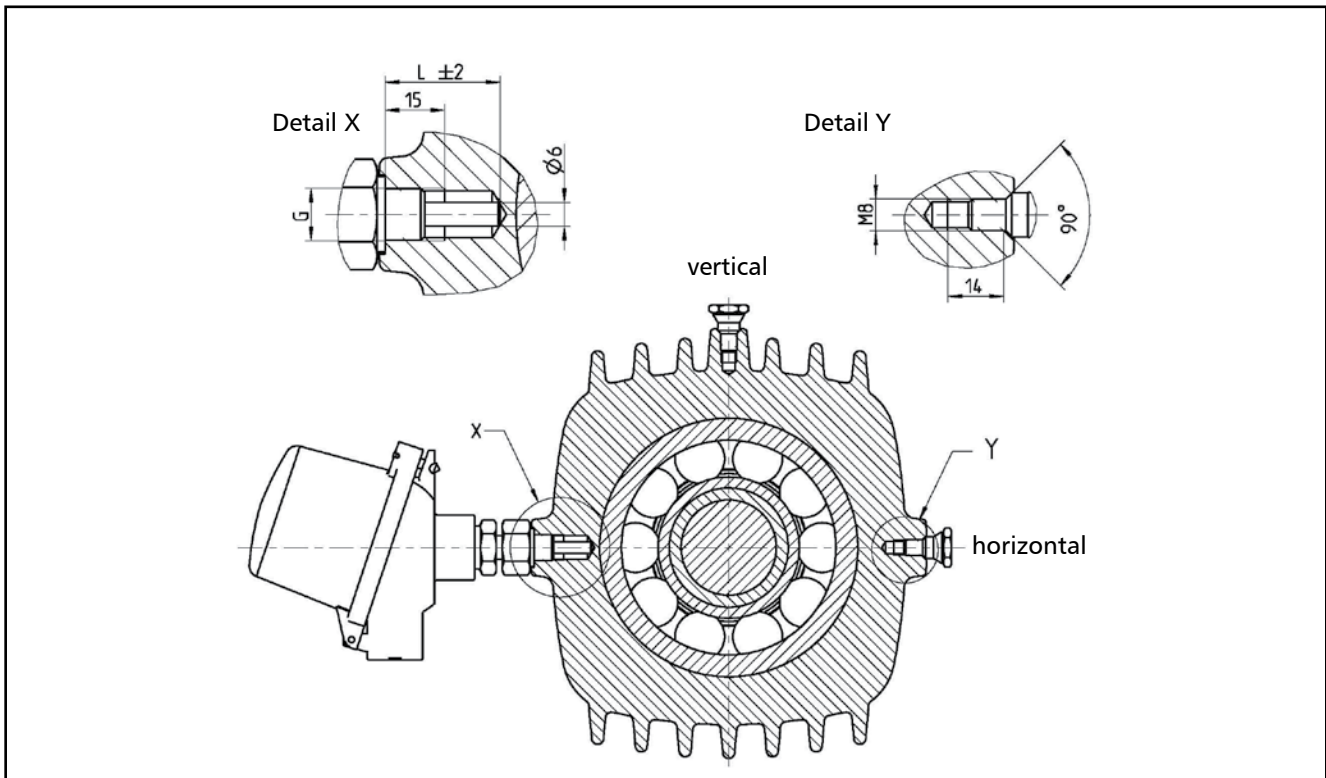

Bearing temperature (X) ¹			
PUMP SIZE	G [inch]	MPA, MPR, MPD	MPV
		L [mm]	L [mm]
50	G1/4	20	80
65	G1/4	25	94
100	G1/4	20	101
125	G1/4	25	114
150	G1/4	30	130

Bearing vibrations sensors (Y)²

1 = Bearing temperature sensor: eg. PT100 - (4 to 20 mA)

2 = Bearing vibration nipple: eg. SPM 32000

Different adapters for customer requirements possible

MP-sensor_a_td

REPORTS AND DECLARATIONS

REPORTS AND DECLARATIONS

i) Test reports

a) Factory Test Report

(not available for all pump types; contact Customer Service in advance)

- Test report compiled at the end of the assembly line, including flow-head performance test (ISO 9906:2012) and tightness test.

b) Audit Test Report

- Test report for electric pumps compiled in the test room, comprising flow-head-pump input-pump efficiency performance test (ISO 9906:2012)

c) NPSH Test Report

- Test report for electric pumps compiled in the test room, comprising flow-NPSH performance test (ISO 9906:2012)

d) Noise Test Report

- Report indicating sound pressure and power measurements (EN ISO 20361, EN ISO 11203, EN ISO 4871)

e) Vibration Test Report

- Report indicating vibration measurements (ISO 10816-1)

ii) Declaration of product conformity with the technical requirements indicated in the order

a) EN 10204:2004 - type 2.1

- does not include test results on supplied or similar products.

b) EN 10204:2004 - type 2.2

- includes test results (materials certificates) on similar products.

iii) Issue of a further EC Declaration of Conformity,

- in addition to the one accompanying the product, it comprises references to European law and the main technical standards (e.g.: MD 2006/42/EC, EMC 2004/108/EC, ErP 2009/125/EC).

N.B.: if the request is made after receipt of the product, communicate the code (name) and serial number (date + progressive number).

iv) Manufacturer's declaration of conformity

- relative to one of more types of products without indicating specific codes and serial numbers.

v) Other certificates and/or documentation on request

- subject to availability or feasibility.

vi) Duplication of certificates and/or documentation on request

- subject to availability or feasibility.

TECHNICAL APPENDIX

e-MP SERIES FORCES AND MOMENTS AT PUMP FLANGES

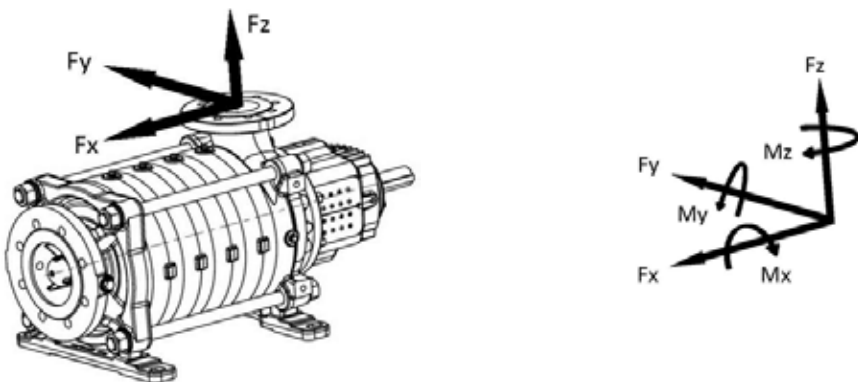
PERMISSIBLE FORCES AND MOMENTS AT PUMP FLANGES								
Forces and moments for horizontal pump similar to ISO5199								
Top flange (eMPA / e-MPR / e-MPD)								
								
	Material code: CCC, CBC, CNC							
DN	Fx [N]	Fy [N]	Fz [N]	ΣF [N]	Mx [Nm]	My [Nm]	Mz [Nm]	ΣM [Nm]
50	450	405	495	782	389	249	302	552
65	555	510	630	982	424	284	319	602
80	675	615	750	1182	459	302	354	654
100	900	810	1005	1574	512	337	407	735
125	1065	960	1185	1860	634	424	564	949
150	1350	1215	1500	2356	774	512	617	1114
200	1800	1620	2010	3147	1037	704	827	1501
	Material code: DCC, DBC, DNC, NNN, RNN, RRR, TTT							
DN	Fx [N]	Fy [N]	Fz [N]	ΣF [N]	Mx [Nm]	My [Nm]	Mz [Nm]	ΣM [Nm]
900	810	990	1564	778	498	603	1104	
1110	1020	1260	1965	848	568	638	1204	
1350	1230	1500	2363	918	603	708	1307	
1800	1620	2010	3147	1023	673	813	1471	
2130	1920	2370	3720	1268	848	1128	1898	
2700	2430	3000	4711	1548	1023	1233	2228	
3600	3240	4020	6294	2073	1408	1653	3003	

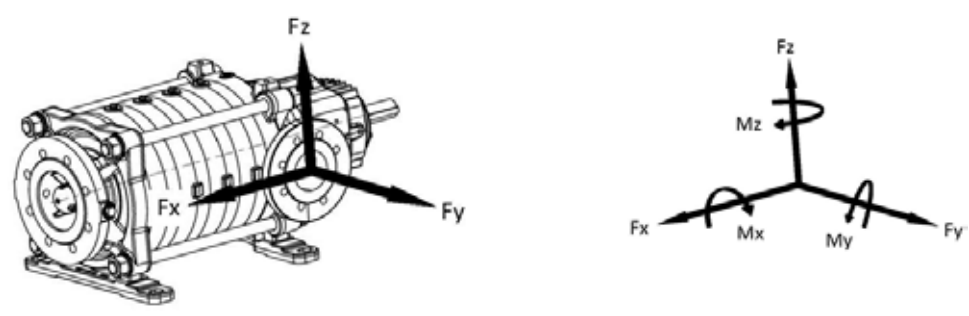
Side flange (eMPA / e-MPR / e-MPD)								
								
	Material code: CCC, CBC, CNC							
DN	Fx [N]	Fy [N]	Fz [N]	ΣF [N]	Mx [Nm]	My [Nm]	Mz [Nm]	ΣM [Nm]
50	450	495	405	782	389	249	302	552
65	555	630	510	982	424	284	319	602
80	675	750	615	1182	459	302	354	654
100	900	1005	810	1574	512	337	407	735
125	1065	1185	960	1860	634	424	564	949
150	1350	1500	1215	2356	774	512	617	1114
200	1800	2010	1620	3147	1037	704	827	1501
	Material code: DCC, DBC, DNC, NNN, RNN, RRR, TTT							
DN	Fx [N]	Fy [N]	Fz [N]	ΣF [N]	Mx [Nm]	My [Nm]	Mz [Nm]	ΣM [Nm]
900	990	810	1564	778	498	603	1104	
1110	1260	1020	1965	848	568	638	1204	
1350	1500	1230	2363	918	603	708	1307	
1800	2010	1620	3147	1023	673	813	1471	
2130	2370	1920	3720	1268	848	1128	1898	
2700	3000	2430	4711	1548	1023	1233	2228	
3600	4020	3240	6294	2073	1408	1653	3003	

e-MP SERIES FORCES AND MOMENTS AT PUMP FLANGES

PERMISSIBLE FORCES AND MOMENTS AT PUMP FLANGES																
Forces and moments for horizontal pump similar to ISO5199																
End flange (eMPA)																
	Material code: CCC, CBC, CNC								Material code: DCC, DBC, DNC, NNN, RNN, RRR, TTT							
	Fx	Fy	Fz	ΣF	Mx	My	Mz	ΣM	Fx	Fy	Fz	ΣF	Mx	My	Mz	ΣM
DN	[N]	[N]	[N]	[N]	[Nm]	[Nm]	[Nm]	[Nm]	[N]	[N]	[N]	[N]	[Nm]	[Nm]	[Nm]	[Nm]
100	1005	900	810	1574	512	337	407	735	2010	1800	1620	3147	1023	673	813	1471
125	1185	1065	960	1860	634	424	564	949	2370	2130	1920	3720	1268	848	1128	1898
150	1500	1350	1215	2356	774	512	617	1114	3000	2700	2430	4711	1548	1023	1233	2228
200	2010	1800	1620	3147	1037	704	827	1501	4020	3600	3240	6294	2073	1408	1653	3003
250	2505	2235	2025	3921	1457	1002	1177	2124	5010	4470	4050	7841	2913	2003	2353	4247

Forces and moments for vertical pump similar to ISO5199																
Side flange (eMPV)																
	Material code: CCC, CBC, CNC								Material code: DCC, DBC, DNC, NNN, RNN, RRR, TTT							
	Fx	Fy	Fz	ΣF	Mx	My	Mz	ΣM	Fx	Fy	Fz	ΣF	Mx	My	Mz	ΣM
DN	[N]	[N]	[N]	[N]	[Nm]	[Nm]	[Nm]	[Nm]	[N]	[N]	[N]	[N]	[Nm]	[Nm]	[Nm]	[Nm]
50	450	495	405	782	389	249	302	552	900	990	810	1564	778	498	603	1104
65	555	630	510	982	424	284	319	602	1110	1260	1020	1965	848	568	638	1204
80	675	750	615	1182	459	302	354	654	1350	1500	1230	2363	918	603	708	1307
100	900	1005	810	1574	512	337	407	735	1800	2010	1620	3147	1023	673	813	1471
125	1065	1185	960	1860	634	424	564	949	2130	2370	1920	3720	1268	848	1128	1898
150	1350	1500	1215	2356	774	512	617	1114	2700	3000	2430	4711	1548	1023	1233	2228
200	1800	2010	1620	3147	1037	704	827	1501	3600	4020	3240	6294	2073	1408	1653	3003

NPSH

The minimum operating values that can be reached at the pump suction end are limited by the onset of cavitation.

Cavitation is the formation of vapour-filled cavities within liquids where the pressure is locally reduced to a critical value, or where the local pressure is equal to, or just below the vapour pressure of the liquid.

The vapour-filled cavities flow with the current and when they reach a higher pressure area the vapour contained in the cavities condenses. The cavities collide, generating pressure waves that are transmitted to the walls. These, being subjected to stress cycles, gradually become deformed and yield due to fatigue. This phenomenon, characterized by a metallic noise produced by the hammering on the pipe walls, is called incipient cavitation.

The damage caused by cavitation may be magnified by electrochemical corrosion and a local rise in temperature due to the plastic deformation of the walls. The materials that offer the highest resistance to heat and corrosion are alloy steels, especially austenitic steel. The conditions that trigger cavitation may be assessed by calculating the total net suction head, referred to in technical literature with the acronym NPSH (Net Positive Suction Head).

The NPSH represents the total energy (expressed in m.) of the liquid measured at suction under conditions of incipient cavitation, excluding the vapour pressure (expressed in m.) that the liquid has at the pump inlet.

To find the static height h_z at which to install the machine under safe conditions, the following formula must be verified:

$$h_p + h_z \geq (NPSH_r + 0.5) + h_f + h_{pv} \quad \textcircled{1}$$

where:

- h_p** is the absolute pressure applied to the free liquid surface in the suction tank, expressed in m. of liquid; h_p is the quotient between the barometric pressure and the specific weight of the liquid.
- h_z** is the suction lift between the pump axis and the free liquid surface in the suction tank, expressed in m.; h_z is negative when the liquid level is lower than the pump axis.
- h_f** is the flow resistance in the suction line and its accessories, such as: fittings, foot valve, gate valve, elbows, etc.
- h_{pv}** is the vapour pressure of the liquid at the operating temperature, expressed in m. of liquid. h_{pv} is the quotient between the P_v vapour pressure and the liquid's specific weight.
- 0,5** is the safety factor.

The maximum possible suction head for installation depends on the value of the atmospheric pressure (i.e. the elevation above sea level at which the pump is installed) and the temperature of the liquid.

To help the user, with reference to water temperature (4° C) and to the elevation above sea level, the following tables show the drop in hydraulic pressure head in relation to the elevation above sea level, and the suction loss in relation to temperature.

Water temperature (°C)	20	40	60	80	90	110	120
Suction loss (m)	0,2	0,7	2,0	5,0	7,4	15,4	21,5

Elevation above sea level (m)	500	1000	1500	2000	2500	3000
Suction loss (m)	0,55	1,1	1,65	2,2	2,75	3,3

Friction loss is shown in the tables Flow Resistance of this catalogue. To reduce it to a minimum, especially in cases of high suction head (over 4-5 m.) or within the operating limits with high flow rates, we recommend using a suction line having a larger diameter than that of the pump's suction port. It is always a good idea to position the pump as close as possible to the liquid to be pumped.

Make the following calculation:

Liquid: water at ~15°C $\gamma = 1 \text{ kg/dm}^3$

Flow rate required: 25 m³/h

Head for required delivery: 70 m.

Suction lift: 3,5 m.

The selection is an 33SV3G075T pump whose NPSH required value is, at 25 m³/h, of 2 m.

For water at 15 °C

$$h_p = P_a / \gamma = 10,33\text{m}, h_{pv} = P_v / \gamma = 0,174\text{m} (0,01701 \text{ bar})$$

The H_f flow resistance in the suction line with foot valves is ~ 1,2 m.

By substituting the parameters in formula $\textcircled{1}$ with the numeric values above, we have:

$$10,33 + (-3,5) \geq (2 + 0,5) + 1,2 + 0,17$$

from which we have: 6,8 > 3,9

The relation is therefore verified.

VAPOUR PRESSURE

VAPOUR PRESSURE p_s AND ρ DENSITY OF WATER TABLE

t °C	T K	p_s bar	ρ kg/dm ³	t °C	T K	p_s bar	ρ kg/dm ³	t °C	T K	p_s bar	ρ kg/dm ³
0	273,15	0,00611	0,9998	55	328,15	0,15741	0,9857	120	393,15	1,9854	0,9429
1	274,15	0,00657	0,9999	56	329,15	0,16511	0,9852	122	395,15	2,1145	0,9412
2	275,15	0,00706	0,9999	57	330,15	0,17313	0,9846	124	397,15	2,2504	0,9396
3	276,15	0,00758	0,9999	58	331,15	0,18147	0,9842	126	399,15	2,3933	0,9379
4	277,15	0,00813	1,0000	59	332,15	0,19016	0,9837	128	401,15	2,5435	0,9362
5	278,15	0,00872	1,0000	60	333,15	0,1992	0,9832	130	403,15	2,7013	0,9346
6	279,15	0,00935	1,0000	61	334,15	0,2086	0,9826	132	405,15	2,867	0,9328
7	280,15	0,01001	0,9999	62	335,15	0,2184	0,9821	134	407,15	3,041	0,9311
8	281,15	0,01072	0,9999	63	336,15	0,2286	0,9816	136	409,15	3,223	0,9294
9	282,15	0,01147	0,9998	64	337,15	0,2391	0,9811	138	411,15	3,414	0,9276
10	283,15	0,01227	0,9997	65	338,15	0,2501	0,9805	140	413,15	3,614	0,9258
11	284,15	0,01312	0,9997	66	339,15	0,2615	0,9799	145	418,15	4,155	0,9214
12	285,15	0,01401	0,9996	67	340,15	0,2733	0,9793	155	428,15	5,433	0,9121
13	286,15	0,01497	0,9994	68	341,15	0,2856	0,9788	160	433,15	6,181	0,9073
14	287,15	0,01597	0,9993	69	342,15	0,2984	0,9782	165	438,15	7,008	0,9024
15	288,15	0,01704	0,9992	70	343,15	0,3116	0,9777	170	443,15	7,920	0,8973
16	289,15	0,01817	0,9990	71	344,15	0,3253	0,9770	175	448,15	8,924	0,8921
17	290,15	0,01936	0,9988	72	345,15	0,3396	0,9765	180	453,15	10,027	0,8869
18	291,15	0,02062	0,9987	73	346,15	0,3543	0,9760	185	458,15	11,233	0,8815
19	292,15	0,02196	0,9985	74	347,15	0,3696	0,9753	190	463,15	12,551	0,8760
20	293,15	0,02337	0,9983	75	348,15	0,3855	0,9748	195	468,15	13,987	0,8704
21	294,15	0,24850	0,9981	76	349,15	0,4019	0,9741	200	473,15	15,550	0,8647
22	295,15	0,02642	0,9978	77	350,15	0,4189	0,9735	205	478,15	17,243	0,8588
23	296,15	0,02808	0,9976	78	351,15	0,4365	0,9729	210	483,15	19,077	0,8528
24	297,15	0,02982	0,9974	79	352,15	0,4547	0,9723	215	488,15	21,060	0,8467
25	298,15	0,03166	0,9971	80	353,15	0,4736	0,9716	220	493,15	23,198	0,8403
26	299,15	0,03360	0,9968	81	354,15	0,4931	0,9710	225	498,15	25,501	0,8339
27	300,15	0,03564	0,9966	82	355,15	0,5133	0,9704	230	503,15	27,976	0,8273
28	301,15	0,03778	0,9963	83	356,15	0,5342	0,9697	235	508,15	30,632	0,8205
29	302,15	0,04004	0,9960	84	357,15	0,5557	0,9691	240	513,15	33,478	0,8136
30	303,15	0,04241	0,9957	85	358,15	0,5780	0,9684	245	518,15	36,523	0,8065
31	304,15	0,04491	0,9954	86	359,15	0,6011	0,9678	250	523,15	39,776	0,7992
32	305,15	0,04753	0,9951	87	360,15	0,6249	0,9671	255	528,15	43,246	0,7916
33	306,15	0,05029	0,9947	88	361,15	0,6495	0,9665	260	533,15	46,943	0,7839
34	307,15	0,05318	0,9944	89	362,15	0,6749	0,9658	265	538,15	50,877	0,7759
35	308,15	0,05622	0,9940	90	363,15	0,7011	0,9652	270	543,15	55,058	0,7678
36	309,15	0,05940	0,9937	91	364,15	0,7281	0,9644	275	548,15	59,496	0,7593
37	310,15	0,06274	0,9933	92	365,15	0,7561	0,9638	280	553,15	64,202	0,7505
38	311,15	0,06624	0,9930	93	366,15	0,7849	0,9630	285	558,15	69,186	0,7415
39	312,15	0,06991	0,9927	94	367,15	0,8146	0,9624	290	563,15	74,461	0,7321
40	313,15	0,07375	0,9923	95	368,15	0,8453	0,9616	295	568,15	80,037	0,7223
41	314,15	0,07777	0,9919	96	369,15	0,8769	0,9610	300	573,15	85,927	0,7122
42	315,15	0,08198	0,9915	97	370,15	0,9094	0,9602	305	578,15	92,144	0,7017
43	316,15	0,09639	0,9911	98	371,15	0,9430	0,9596	310	583,15	98,70	0,6906
44	317,15	0,09100	0,9907	99	372,15	0,9776	0,9586	315	588,15	105,61	0,6791
45	318,15	0,09582	0,9902	100	373,15	1,0133	0,9581	320	593,15	112,89	0,6669
46	319,15	0,10086	0,9898	102	375,15	1,0878	0,9567	325	598,15	120,56	0,6541
47	320,15	0,10612	0,9894	104	377,15	1,1668	0,9552	330	603,15	128,63	0,6404
48	321,15	0,11162	0,9889	106	379,15	1,2504	0,9537	340	613,15	146,05	0,6102
49	322,15	0,11736	0,9884	108	381,15	1,3390	0,9522	350	623,15	165,35	0,5743
50	323,15	0,12335	0,9880	110	383,15	1,4327	0,9507	360	633,15	186,75	0,5275
51	324,15	0,12961	0,9876	112	385,15	1,5316	0,9491	370	643,15	210,54	0,4518
52	325,15	0,13613	0,9871	114	387,15	1,6362	0,9476	374,15	647,30	221,20	0,3154
53	326,15	0,14293	0,9862	116	389,15	1,7465	0,9460				
54	327,15	0,15002	0,9862	118	391,15	1,8628	0,9445				

G-at_npsb_sc

TABLE OF FLOW RESISTANCE IN 100 m OF STRAIGHT CAST IRON PIPELINE (HAZEN-WILLIAMS FORMULA C=100)

FLOW RATE		NOMINAL DIAMETER in mm and inches																		
m ³ /h	l/min		15	20	25	32	40	50	65	80	100	125	150	175	200	250	300	350	400	
			1/2"	3/4"	1"	1 1/4"	1 1/2"	2	2 1/2"	3"	4"	5"	6"	7"	8"	10"	12"	14"	16"	
0,6	10	v	0,94	0,53	0,34	0,21	0,13													
		hr	16	3,94	1,33	0,40	0,13													
0,9	15	v	1,42	0,80	0,51	0,31	0,20													
		hr	33,9	8,35	2,82	0,85	0,29													
1,2	20	v	1,89	1,06	0,68	0,41	0,27	0,17												
		hr	57,7	14,21	4,79	1,44	0,49	0,16												
1,5	25	v	2,36	1,33	0,85	0,52	0,33	0,21												
		hr	87,2	21,5	7,24	2,18	0,73	0,25												
1,8	30	v	2,83	1,59	1,02	0,62	0,40	0,25												
		hr	122	30,1	10,1	3,05	1,03	0,35												
2,1	35	v	3,30	1,86	1,19	0,73	0,46	0,30												
		hr	162	40,0	13,5	4,06	1,37	0,46												
2,4	40	v	2,12	1,36	0,83	0,53	0,34	0,20												
		hr		51,2	17,3	5,19	1,75	0,59												
3	50	v		2,65	1,70	1,04	0,66	0,42	0,25											
		hr		77,4	26,1	7,85	2,65	0,89	0,25											
3,6	60	v		3,18	2,04	1,24	0,80	0,51	0,30											
		hr		108	36,6	11,0	3,71	1,25	0,35											
4,2	70	v		3,72	2,38	1,45	0,93	0,59	0,35											
		hr		144	48,7	14,6	4,93	1,66	0,46											
4,8	80	v		4,25	2,72	1,66	1,06	0,68	0,40											
		hr		185	62,3	18,7	6,32	2,13	0,59											
5,4	90	v			3,06	1,87	1,19	0,76	0,45	0,30										
		hr			77,5	23,3	7,85	2,65	0,74	0,27										
6	100	v			3,40	2,07	1,33	0,85	0,50	0,33										
		hr			94,1	28,3	9,54	3,22	0,90	0,33										
7,5	125	v			4,25	2,59	1,66	1,06	0,63	0,41										
		hr			142	42,8	14,4	4,86	1,36	0,49										
9	150	v				3,11	1,99	1,27	0,75	0,50	0,32									
		hr				59,9	20,2	6,82	1,90	0,69	0,23									
10,5	175	v				3,63	2,32	1,49	0,88	0,58	0,37									
		hr				79,7	26,9	9,07	2,53	0,92	0,31									
12	200	v				4,15	2,65	1,70	1,01	0,66	0,42									
		hr				102	34,4	11,6	3,23	1,18	0,40									
15	250	v				5,18	3,32	2,12	1,26	0,83	0,53	0,34								
		hr				154	52,0	17,5	4,89	1,78	0,60	0,20								
18	300	v					3,98	2,55	1,51	1,00	0,64	0,41								
		hr					72,8	24,6	6,85	2,49	0,84	0,28								
24	400	v					5,31	3,40	2,01	1,33	0,85	0,54	0,38							
		hr					124	41,8	11,66	4,24	1,43	0,48	0,20							
30	500	v					6,63	4,25	2,51	1,66	1,06	0,68	0,47							
		hr					187	63,2	17,6	6,41	2,16	0,73	0,30							
36	600	v						5,10	3,02	1,99	1,27	0,82	0,57	0,42						
		hr						88,6	24,7	8,98	3,03	1,02	0,42	0,20						
42	700	v						5,94	3,52	2,32	1,49	0,95	0,66	0,49						
		hr						118	32,8	11,9	4,03	1,36	0,56	0,26						
48	800	v						6,79	4,02	2,65	1,70	1,09	0,75	0,55						
		hr						151	42,0	15,3	5,16	1,74	0,72	0,34						
54	900	v						7,64	4,52	2,99	1,91	1,22	0,85	0,62						
		hr						188	52,3	19,0	6,41	2,16	0,89	0,42						
60	1000	v							5,03	3,32	2,12	1,36	0,94	0,69	0,53					
		hr							63,5	23,1	7,79	2,63	1,08	0,51	0,27					
75	1250	v							6,28	4,15	2,65	1,70	1,18	0,87	0,66					
		hr							96,0	34,9	11,8	3,97	1,63	0,77	0,40					
90	1500	v							7,54	4,98	3,18	2,04	1,42	1,04	0,80					
		hr							134	48,9	16,5	5,57	2,29	1,08	0,56					
105	1750	v							8,79	5,81	3,72	2,38	1,65	1,21	0,93					
		hr							179	65,1	21,9	7,40	3,05	1,44	0,75					
120	2000	v								6,63	4,25	2,72	1,89	1,39	1,06	0,68				
		hr								83,3	28,1	9,48	3,90	1,84	0,96	0,32				
150	2500	v								8,29	5,31	3,40	2,36	1,73	1,33	0,85				
		hr								126	42,5	14,3	5,89	2,78	1,45	0,49				
180	3000	v									6,37	4,08	2,83	2,08	1,59	1,02	0,71			
		hr									59,5	20,1	8,26	3,90	2,03	0,69	0,28			
210	3500	v									7,43	4,76	3,30	2,43	1,86	1,19	0,83			
		hr									79,1	26,7	11,0	5,18	2,71	0,91	0,38			
240	4000	v									8,49	5,44	3,77	2,77	2,12	1,36	0,94			
		hr									101	34,2	14,1	6,64	3,46	1,17	0,48			
300	5000	v										6,79	4,72	3,47	2,65	1,70	1,18			
		hr										51,6	21,2	10,0	5,23	1,77	0,73			
360	6000	v										8,15	5,66	4,16	3,18	2,04	1,42			
		hr										72,3	29,8	14,1	7,33	2,47	1,02			
420	7000	v											6,61	4,85	3,72	2,38	1,65	1,21		
		hr											39,6	18,7	9,75	3,29	1,35	0,64		
480	8000	v											7,55	5,55	4,25	2,72	1,89	1,39		
		hr											50,7	23,9	12,49	4,21	1,73	0,82		
540	9000	v											8,49	6,24	4,78	3,06	2,12	1,56	1,19	
		hr											63,0	29,8	15,5	5,24	2,16	1,02	0,53	
600	10000	v												6,93	5,31	3,40	2,36	1,73	1,33	

FLOW RESISTANCE TABLE OF FLOW RESISTANCE IN BENDS, VALVES AND GATES

The flow resistance is calculated using the equivalent pipeline length method according to the table below:

ACCESSORY TYPE	DN											
	25	32	40	50	65	80	100	125	150	200	250	300
	Equivalent pipeline length (m)											
45° bend	0,2	0,2	0,4	0,4	0,6	0,6	0,9	1,1	1,5	1,9	2,4	2,8
90° bend	0,4	0,6	0,9	1,1	1,3	1,5	2,1	2,6	3,0	3,9	4,7	5,8
90° smooth bend	0,4	0,4	0,4	0,6	0,9	1,1	1,3	1,7	1,9	2,8	3,4	3,9
Union tee or cross	1,1	1,3	1,7	2,1	2,6	3,2	4,3	5,3	6,4	7,5	10,7	12,8
Gate	-	-	-	0,2	0,2	0,2	0,4	0,4	0,6	0,9	1,1	1,3
Non return valve	1,1	1,5	1,9	2,4	3,0	3,4	4,7	5,9	7,4	9,6	11,8	13,9

G-a-pcv-en_a_th

The table is valid for the Hazen Williams coefficient $C=100$ (cast iron pipework);

for steel pipework, multiply the values by 1,41;

for stainless steel, copper and coated cast iron pipework, multiply the values by 1,85;

When the **equivalent pipeline length** has been determined, the flow resistance is obtained from the table of flow resistance.

The values given are guideline values which are bound to vary slightly according to the model, especially for gate valves and non-return valves, for which it is a good idea to check the values supplied by manufacturers.

VOLUMETRIC CAPACITY

Litres per minute l/min	Cubic metres per hour m ³ /h	Cubic feet per hour ft ³ /h	Cubic feet per minute ft ³ /min	Imperial gallon per minute Imp. gal/min	U.S. gallon per minute US gal/min
1,000	0,0600	2,1189	0,0353	0,2200	0,2642
16,6667	1,0000	35,3147	0,5886	3,6662	4,4029
0,4719	0,0283	1,0000	0,0167	0,1038	0,1247
28,3168	1,6990	60,0000	1,0000	6,2288	7,4805
4,5461	0,2728	9,6326	0,1605	1,0000	1,2009
3,7854	0,2271	8,0208	0,1337	0,8327	1,0000

PRESSURE AND HEAD

Newton per square metre N/m ²	kilo Pascal kPa	bar bar	Pound force per square inch psi	Metre of water m H ₂ O	Millimetre of mercury mm Hg
1,0000	0,0010	1 x 10 ⁻⁵	1,45 x 10 ⁻⁴	1,02 x 10 ⁻⁴	0,0075
1 000,0000	1,0000	0,0100	0,1450	0,1020	7,5006
1 x 10 ⁵	100,0000	1,0000	14,5038	10,1972	750,0638
6 894,7570	6,8948	0,0689	1,0000	0,7031	51,7151
9 806,6500	9,8067	0,0981	1,4223	1,0000	73,5561
133,3220	0,1333	0,0013	0,0193	0,0136	1,0000

LENGTH

Millimetre mm	Centimetre cm	Metre m	Inch in	Foot ft	Yard yd
1,0000	0,1000	0,0010	0,0394	0,0033	0,0011
10,0000	1,0000	0,0100	0,3937	0,0328	0,0109
1 000,0000	100,0000	1,0000	39,3701	3,2808	1,0936
25,4000	2,5400	0,0254	1,0000	0,0833	0,0278
304,8000	30,4800	0,3048	12,0000	1,0000	0,3333
914,4000	91,4400	0,9144	36,0000	3,0000	1,0000

VOLUME

Cubic metre m ³	Litre L	Millilitre ml	Imperial gallon imp. gal.	U.S. gallon US gal.	Cubic foot ft ³
1,0000	1 000,0000	1 x 10 ⁶	219,9694	264,1720	35,3147
0,0010	1,0000	1 000,0000	0,2200	0,2642	0,0353
1 x 10 ⁻⁶	0,0010	1,0000	2,2 x 10 ⁻⁴	2,642 x 10 ⁻⁴	3,53 x 10 ⁻⁵
0,0045	4,5461	4 546,0870	1,0000	1,2009	0,1605
0,0038	3,7854	3 785,4120	0,8327	1,0000	0,1337
0,0283	28,3168	28 316,8466	6,2288	7,4805	1,0000

TEMPERATURE

Water	Kelvin K	Celsius °C	Fahrenheit °F	$^{\circ}\text{F} = ^{\circ}\text{C} \times \frac{9}{5} + 32$ $^{\circ}\text{C} = (^{\circ}\text{F} - 32) \times \frac{5}{9}$
icing	273,1500	0,0000	32,0000	
boiling	373,1500	100,0000	212,0000	

G-at_pp-en_b_sc

FURTHER PRODUCT SELECTION AND DOCUMENTATION Xylect™

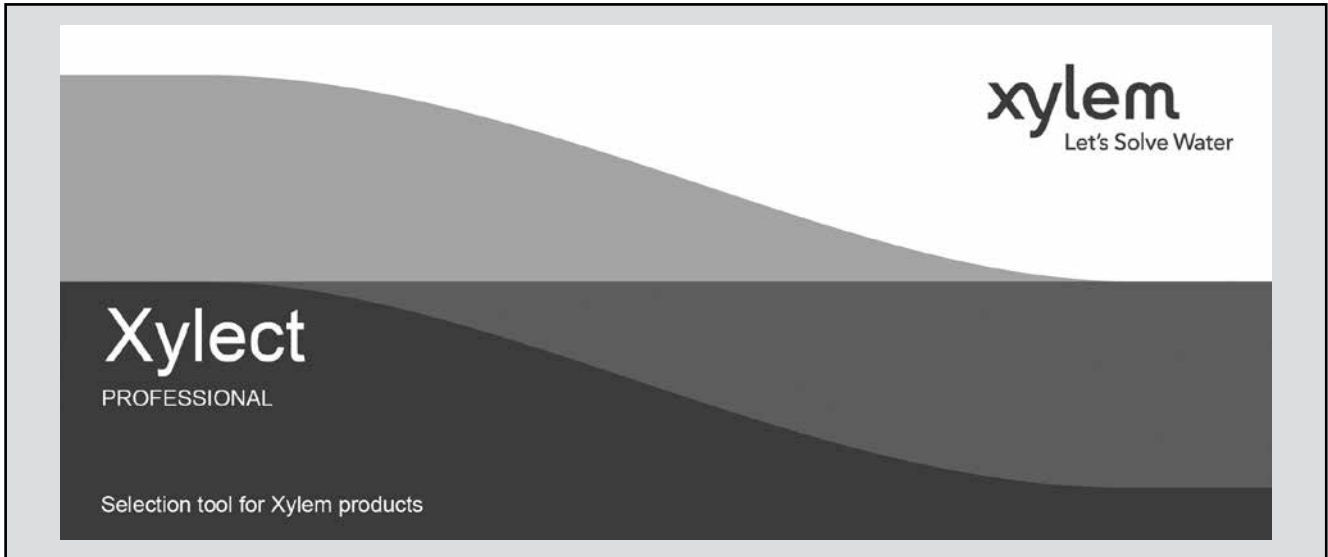

Xylect™ is pump solution selection software with an extensive online database of product information across the entire Lowara range of pumps and related products, with multiple search options and helpful project management facilities. The system holds up-to-date product information on thousands of products and accessories.

The possibility to search by applications and the detailed information output given makes it easy to make the optimal selection without having detailed knowledge about the Lowara products.

The search can be made by:

- Application
- Product type
- Duty point

Xylect™ gives a detailed output:

- List with search results
- Performance curves (flow, head, power, efficiency, NPSH)
- Motor data
- Dimensional drawings
- Options
- Data sheet printouts
- Document downloads incl dxf files

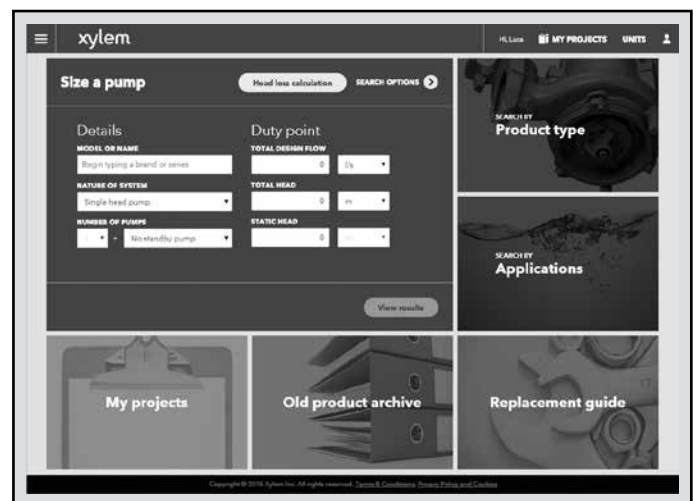

The search by application guides users not familiar with the product range to the right choice.

FURTHER PRODUCT SELECTION AND DOCUMENTATION

Xylect™



The detailed output makes it easy to select the optimal pump from the given alternatives.

The best way to work with Xylect™ is to create a personal account. This makes it possible to:

- Set own standard units
- Create and save projects
- Share projects with other Xylect™ users

Every user has a My Xylect space, where all projects are saved.

For more information about Xylect™ please contact our sales network or visit www.xylect.com.

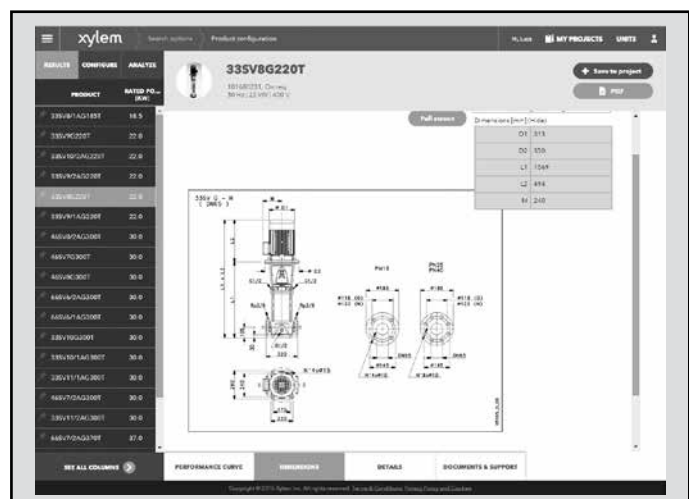

Dimensional drawings appear on the screen and can be downloaded in dxf format.

Xylem |'zīləm|

- 1) The tissue in plants that brings water upward from the roots;
- 2) a leading global water technology company.

We're a global team unified in a common purpose: creating advanced technology solutions to the world's water challenges. Developing new technologies that will improve the way water is used, conserved, and re-used in the future is central to our work. Our products and services move, treat, analyze, monitor and return water to the environment, in public utility, industrial, residential and commercial building services, and agricultural settings. With its October 2016 acquisition of Sensus, Xylem added smart metering, network technologies and advanced data analytics for water, gas and electric utilities to its portfolio of solutions. In more than 150 countries, we have strong, long-standing relationships with customers who know us for our powerful combination of leading product brands and applications expertise with a strong focus on developing comprehensive, sustainable solutions.

For more information on how Xylem can help you, go to www.xylem.com.



Legal head office
Xylem Water Solutions Italia Srl

Via Gioacchino Rossini 1/A
20020 - Lainate (MI) - Italy
Tel. (+39) 02 90358.1
Fax (+39) 02 9019990
www.xylemwatersolutions.com

For information and technical support
Xylem Service Italia Srl

Via Dottor Vittorio Lombardi 14
36075 - Montecchio Maggiore (VI) - Italy
Tel. (+39) 0444 707111
Fax (+39) 0444 491043
www.lowara.com

Xylem Water Solutions Italia Srl reserves the right to make modification without prior notice.
Lowara, Xylem are trademarks of Xylem Inc. or one of its subsidiaries
© 2017 Xylem, Inc.