

GRE

Impeller with grinder system

All product images are indicative only



General characteristics

Impeller with grinder system	
motor power	1,5 kW
poles	2
discharge	GAS 2"-DN32 horizontal
free passage	-
max flow rate	6.3 l/s
max head	27.3 m

Electromechanical assembly

Electromechanical assembly in GJL-250 cast iron, for submerged operation. Seal set comprising 1 (one) silicon carbide mechanical seal and 1 (one) lip seal. Ecological dry motor.

Applications

Suitable for lifting soiled wastewaters containing filaments or fibres, and unstrained household sewage in general.

Construction materials

Case	Cast iron EN-GJL 250
Impeller	Cast iron EN-GJL-250
Nuts and bolts	Stainless steel - Class A2-70
Standard gasket	Rubber - NBR
Cutter material	Chromium steel - X102 CrMo17 KU
Cutting disk material	Chromium steel - X102 CrMo17 KU
Shaft	Stainless steel - AISI 420
Paint type	Ecological bicomponent epoxy (medium thickness 80 µm)
Set of standard mechanical seals	One silicon carbide mechanical seal (SiC) and one lip seal

Operating limits

Maximum operating temperature	40 °C
PH of treated fluid	6 ÷ 14
Viscosity of treated fluid	1 mm ² /s
Maximum immersion depth	20 m
Density of treated fluid	1 Kg/dm ³
Maximum acoustic pressure	70 dB
max starts per hour	30

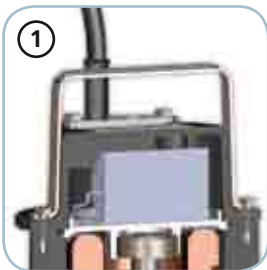
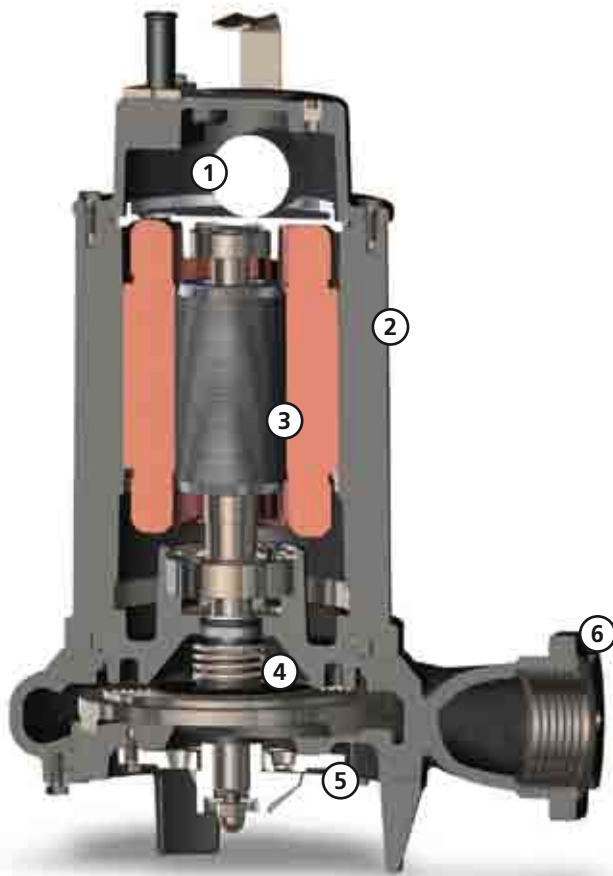

Capacitor/relay

Single-phase models with internal capacitor and control cabinet with circuit breaker capacitor and overload protection. Three-phase models with motor protection relay.

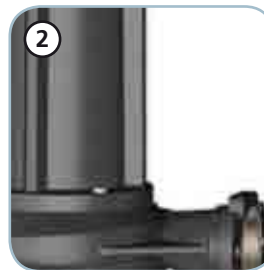

Structure

Constructed in GJL-250 cast iron.

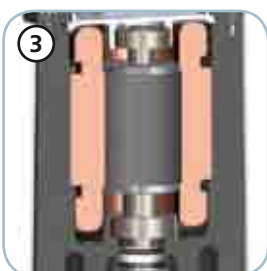

Motor

Ecological dry motor with thermal protections.



Mechanical seals

One mechanical seal in silicon carbide (SiC) and one lip seal.



Grinder system

Grinder system comprising a revolving cutter and a plate with holes with sharpened edges that fine-chops filaments, preventing fouling of the impeller.

Up to 69.000 cuts per minute



Discharge

Threaded, flanged discharge for the maximum ease of installation.

GRE

Models with horizontal GAS 2" threaded - DN32 PN6 flanged discharge - 2 poles

Performances

	l/s	0	1	2	3	4	5	6
	l/min	0	60	120	180	240	300	360
	m ³ /h	0	3.6	7.2	10.8	14.4	18.0	21.6
① GRE 200/2/G50H A0CM(T)50		27.3	25.2	22.9	20.2	16.8	12.4	6.6

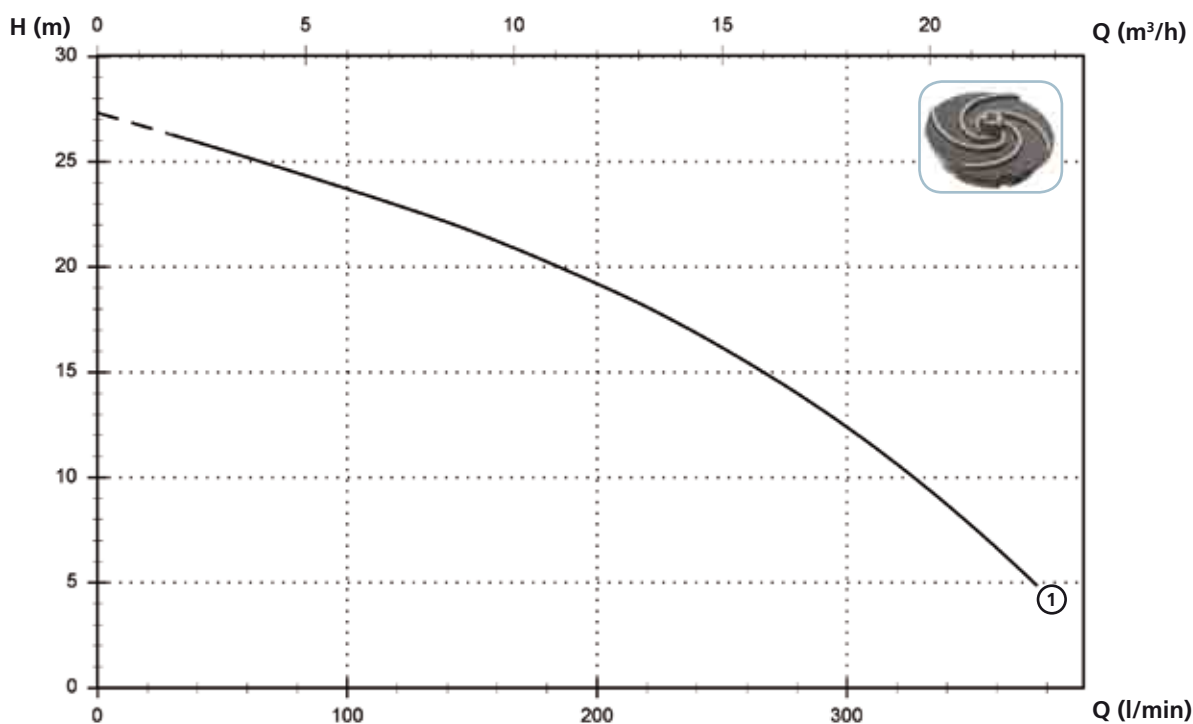

Technical data

	V	Phases	P1 (kW)	P2 (kW)	A	Rpm	Start	Ø	Free passage
① GRE 200/2/G50H A0CM/50	230	1	-	1.7	10.6	2900	Dir	G 2"-DN32 PN6	-
	V	Phases	P1 (kW)	P2 (kW)	A	Rpm	Start	Ø	Free passage
① GRE 200/2/G50H A0CT/50	400	3	-	1.7	3.8	2900	Dir	G 2"-DN32 PN6	-

Versions available

(Key to versions on page 16)

	Electrical variants										Cooling				Mechanical seals				
	N A E	T C	T C D	T C D T	T C D G	T C G	T C S T	T C S G T	T S	T R	T R G	N	CC CCE	FT	C G F T	2SIC	SICM	SICAL	2SICAL
GRE 200/2/G50H A0CM/50				●	●						●						●		
GRE 200/2/G50H A0CT/50									●	●	●						●		

Overall dimensions and weights

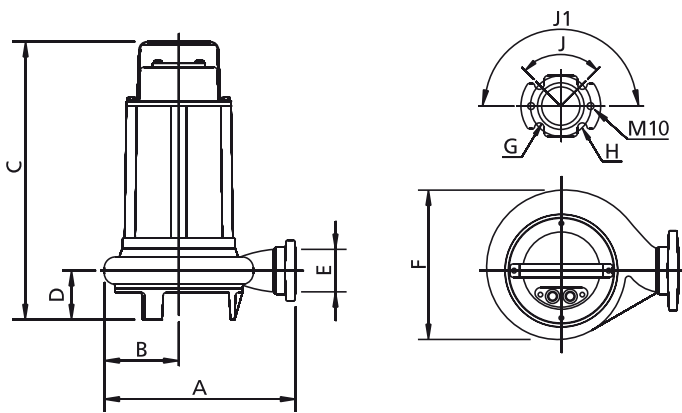

	A	B	C	D	E	F	G	H	J	J1	kg
GRE 200/2/G50H A0CM(T)/50	285	110	410	75	G 2"	220	14	90	90°	180°	26

Dimensions in mm

All weights and dimensions are indicative only

Packaging dimension

	A	B	C
GRE 200/2/G50H A0CM(T)/50	475	285	235

Dimension in mm

All weights and dimensions are indicative only

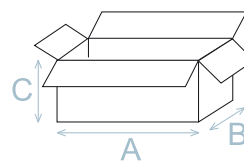

Installations available

