



The electropumps 4SD, 4SDF, 6SDN series comply with the European Regulation no. 547/2012 in force starting from 01.01.2013. **6SD series cannot be sold in the EU.**

Construction

Submersible borehole pumps for 4" wells (Dn 100 mm), and 6" (Dn 150 mm), with external jacket in stainless steel aISI 304 and stages in polycarbonate for 4SD pumps and in noryl for 4SDF, 6SD, 6SDn pumps.

Impellers

radial floating impellers	4SDF 16, 22, 36, 46, 54
radial impellers	4SD 31, - 6SDn 12, 16, 21
mixed flow impellers	4SD 10, 15 - 6SD 18, 19, 20

Connection: screwed connection ISO 228.
Delivery casing with built-in non-return valve.

Applications

For water supply.
For civil and industrial applications.
For fire fighting applications.
For irrigation.

Operating conditions

Liquid temperature: - up to a 35 °C for 4" motors
- up to a 25 °C for 6-8-10" motors.
Max. sand quantity into the water: 150 g/m³.
Continuous duty.

Rewindable motor CS series

2-pole induction motor, 50 Hz (n ≈ 2900 rpm).
Sized for connection to the pumps according to nEMA Standards.
Standard voltages:
- single-phase 230 V up to 2,2 kW for 4" motors.
- three-phase 230 V; 400 V, for 4" motors.
- three-phase 400 V; 400/690 V, for 6" motors.
Voltage tolerance : +6% / -10%.

In order to limit both current and torque at each starting, for rated motor powers equal to or higher than 7.5kW, one of the following types of starting is necessary: star/delta, soft starter, stator impedance or autotransformer.

Motor	Max. Liquid temperature	Cooling : minimum flow velocity	Max. starts per hour
4"	35 °C	0,08 m/s	20
6"	25 °C	0,20 m/s for 4 ÷ 15 kW 0,50 m/s for 18,5 ÷ 30 kW	15

Insulation class F for 4" motors, pVC coated wire for 6" motors. protection Ip 68.

Cable

Motor 230V - 50Hz - 1~	Section	Length
4CS 0,37 ÷ 1,5 kW	3x1,5 + 1G1,5 mm ²	2 m
4CS 2,2 kW	3x2 + 1G2 mm ²	2 m
Motor 400V - 50Hz - 3 ~	Section	Length
4CS 0,37 ÷ 1,5 kW	3x1,5 + 1G1,5 mm ²	2 m
4CS 2,2 ÷ 5,5 kW	3x1,5 + 1G1,5 mm ²	3 m
6CS 4 ÷ 30 kW	4G6 mm ²	3,5 m

Special features on request

- Other voltages. - 60 Hz frequency.
- Other temperatures.
- Motor suitable operation with frequency converter (standard feature for FK).
- encapsulated motor **FK series** (for characteristic see pag. 377).

Designation

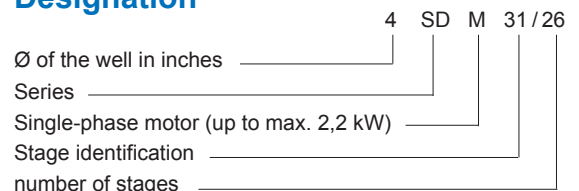

Materials

Components	part nr.	4SD, 4SDF	6SD, 6SDN
external jacket	14.02	Cr-ni steel aISI 304	
Stage casing (4SDF)	25.02	Cr-ni steel aISI 304	-
Stage casing (4,6SD)	25.02	polycarbonate (Lexan 141 R)	GFn2V* (nORyL [®])
Diffuser	26.00		
Impeller	28.00	GFn2V* (nORyL [®])* for 4SDF	(nORyL [®])
Wear ring		Cr-ni steel aISI 304	
Shaft	64.00	Cr steel aISI 430 F	
Delivery casing	12.01	Cr-ni steel aISI 304	Bronze
Suction lantern	32.02		G-Cu Sn 10 en 1982
Bearing bush	12.03-12.30	thermoplastic	Rubber
Strainer	15.50	Cr-ni steel aISI 430	
Screws		Cr-ni steel aISI 304	

* t rademark of General electric

Components	4CS	6CS
external frame	Cr-ni steel aISI 304	
Shaft	Cr-ni-Mo steel aISI 316 (shaft end)	Cr steel aISI 420 Hardened and tempered
thrust bearing	Oil wetted ball type	Oscillation pads
Bearing bush	Oil wetted ball type	Graphite

Coverage chart $n \approx 2900$ rpm

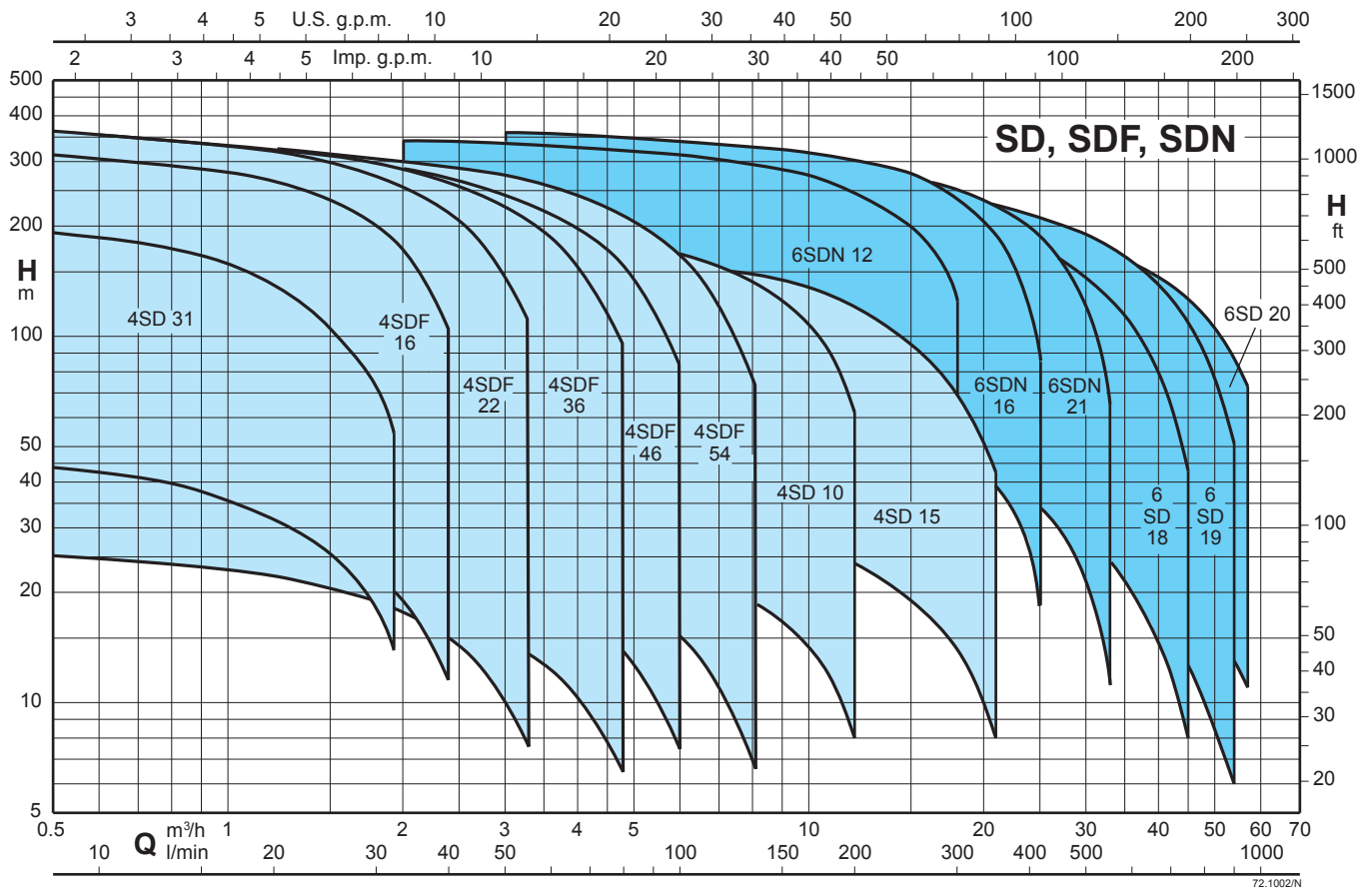

Regulation (EU) No 547/2012

- the benchmark for most efficient water pumps is $MeI \geq 0,70$.
- the efficiency of a pump with a trimmed impeller is usually lower than that of a pump with the full impeller diameter. The trimming of the impeller will adapt the pump to a fixed duty point, leading to reduced energy consumption. The minimum efficiency index (MeI) is based on the full impeller diameter.
- the operation of this water pump with variable duty points may be more efficient and economic when controlled, for example, by the use of a variable speed drive that matches the pump duty to the system.

Characteristic curves, performance $n \approx 2900$ rpm, dimensions and weights

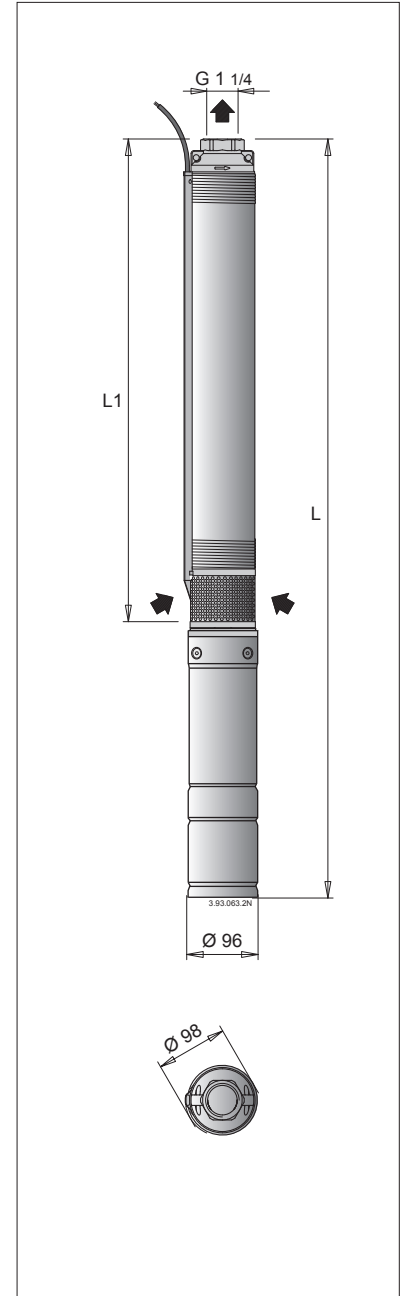
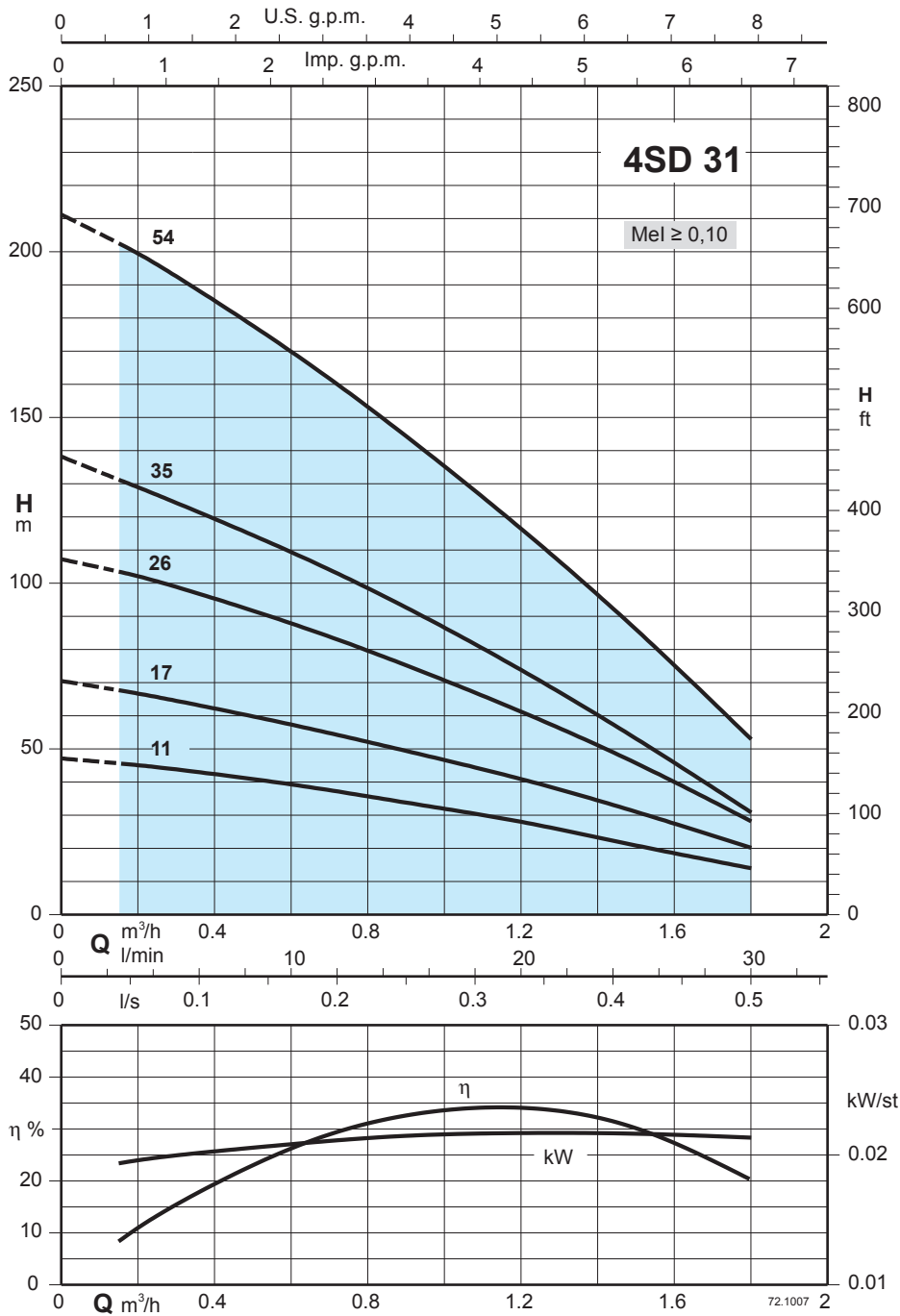

3~	400 V (380-415) 50 Hz	1~	230V *				P1	P2	Q	$n \approx 2900$ rpm													
			450 Vc		kW	kW				HP	m ³ /h	n ≈ 2900 rpm											
			A	μF								0	0,15	0,3	0,6	0,9	1,2	1,5	1,8				
4SD 31/11EC	1,2	4SDM 31/11EC	3,2	16	0,62	0,37	0,5	H m	47	45,6	43,8	39,3	33,8	28	20,9	14							
4SD 31/17EC	1,2	4SDM 31/17EC	3,2	16	0,7	0,37	0,5		70,5	67,7	64,5	57,3	49,4	40,9	31	20,2							
4SD 31/26EC	1,5	4SDM 31/26EC	4	25	0,89	0,55	0,75		107	104	98,9	87,9	75,2	61,2	45,7	28,1							
4SD 31/35EC	2	4SDM 31/35EC	5,6	35	1,22	0,75	1		138	131	124	109	92,6	73,8	53,1	30,8							
4SD 31/54EC	2,9	4SDM 31/54EC	8,4	40	1,82	1,1	1,5		211	203	193	170	144	116	86	52,9							

L1	4SD		4SDM	
	L	kg	L	kg
402	729	12	729	11,6
520	847	13	847	12,6
698	1045	13,5	1060	15,7
875	1237	15,8	1277	18,3
1295	1697	20	1742	23,3

p1 Max. power input p2 Rated motor power output * Only for single-phase motor 230 V - 50 Hz (on request) tolerances according to Unl en ISO 9906:2012

Characteristic curves, performance $n \approx 2900$ rpm, dimensions and weights

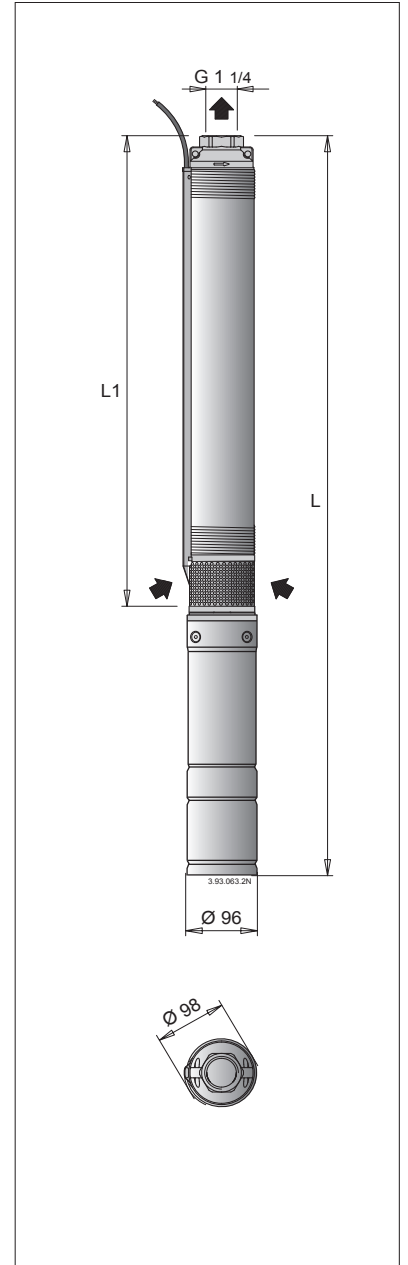
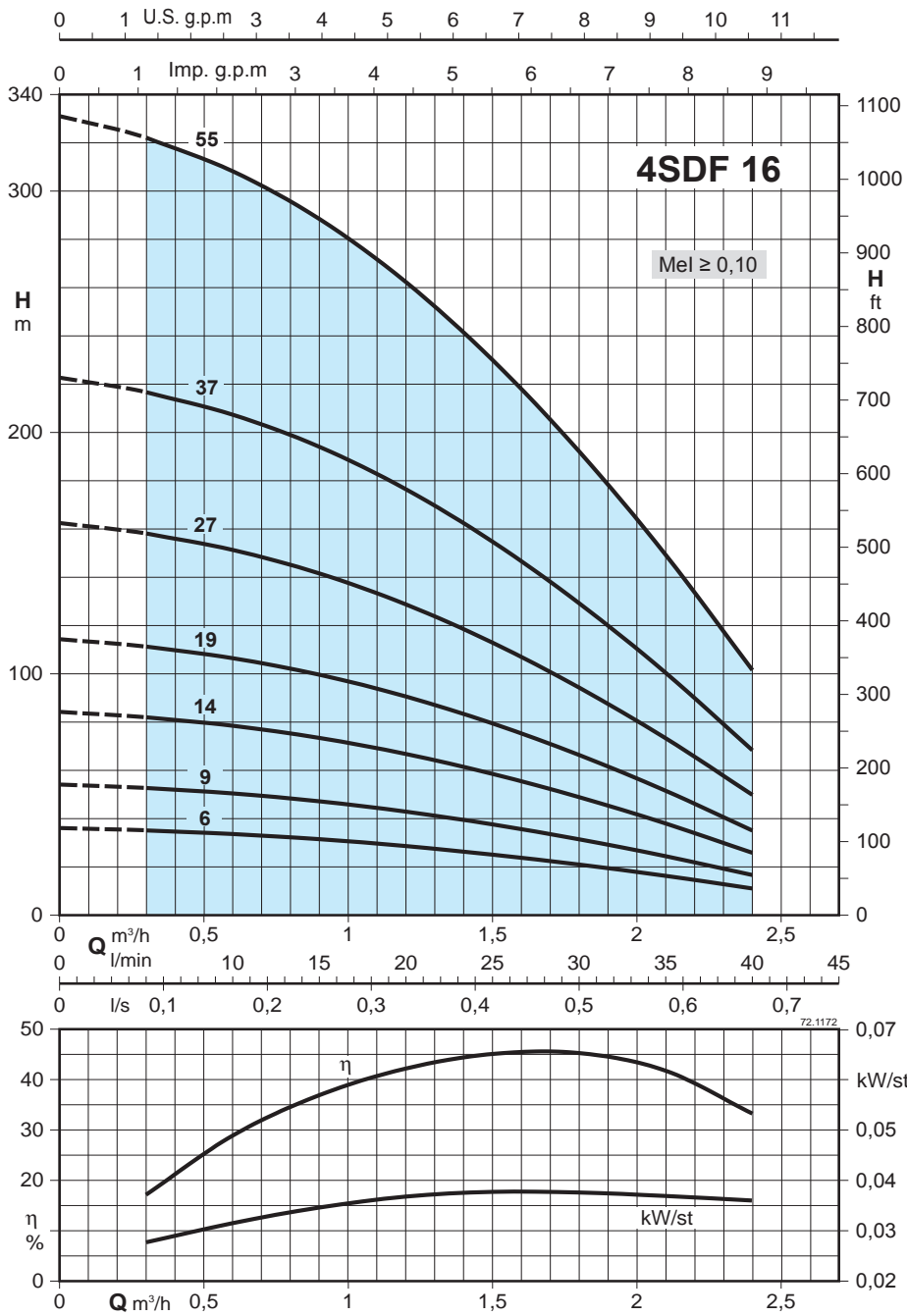

40

	400 V (380-415) 50 Hz		1~ 230V * P1 p2				Q m³/h l/min	n ≈ 2900 rpm										
	A		A	μF	kW	kW		Hp	0	0,3	0,6	0,9	1,2	1,5	1,8	2,1	2,4	
4SDF 16/6EC	1,2		4SDFM 16/6EC	3,2	16	0,62	0,37	0,5	36,1	35,1	33,6	31,5	28,6	25,1	21	16,3	11,1	
4SDF 16/9EC	1,2		4SDFM 16/9EC	3,2	16	0,7	0,37	0,5	54,2	52,7	50,4	47,2	42,9	37,6	31,4	24,4	16,6	
4SDF 16/14EC	1,5		4SDFM 16/14EC	4	25	0,89	0,55	0,75	84,3	82	78,5	73,4	66,8	58,5	48,9	38	25,8	
4SDF 16/19EC	2		4SDFM 16/19EC	5,6	35	1,22	0,75	1	114	111	106	100	90,6	79,5	66,4	51,5	35,1	
4SDF 16/27EC	2,9		4SDFM 16/27EC	8,4	40	1,82	1,1	1,5	163	158	151	142	129	113	94,3	73,2	49,8	
4SDF 16/37EC	4,2		4SDFM 16/37EC	11,2	60	2,33	1,5	2	223	217	207	194	176	155	129	100	68,3	
4SDF 16/55EC	5,5		4SDFM 16/55EC	14,7	70	3,27	2,2	3	331	322	308	288	262	230	192	149	102	

L1 mm	4SDF		4SDFM	
	L mm	kg	L mm	kg
305	632	11	632	11,1
365	692	11,5	692	11,6
465	812	13,4	827	12,7
565	927	15,6	967	14,8
725	1127	18	1172	17,4
915	1362	21,7	1382	22,8
1325	1727	24,6	1842	30,6

p1 Max. power input p2 Rated motor power output * Only for single-phase motor 230 V - 50 Hz (on request) tolerances according to Unl en ISO 9906:2012

Characteristic curves, performance $n \approx 2900$ rpm, dimensions and weights

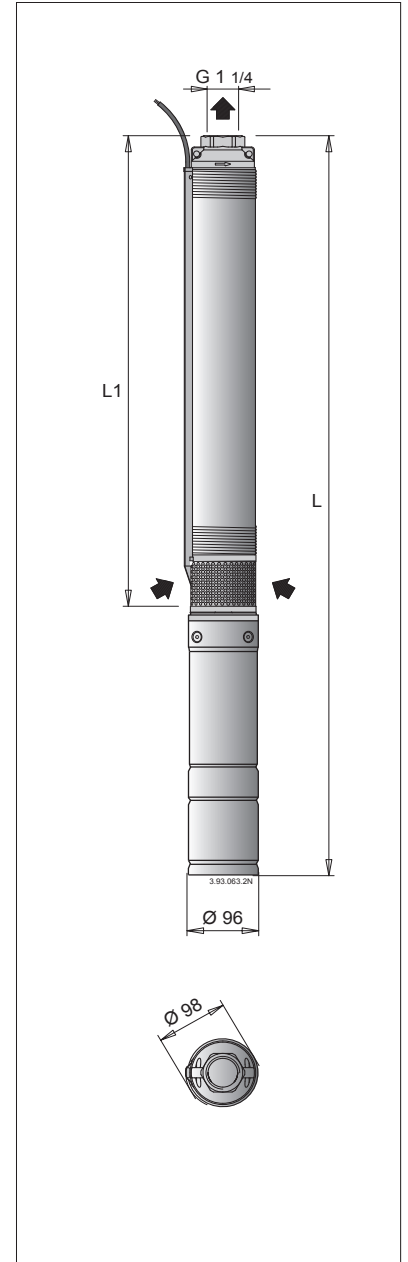
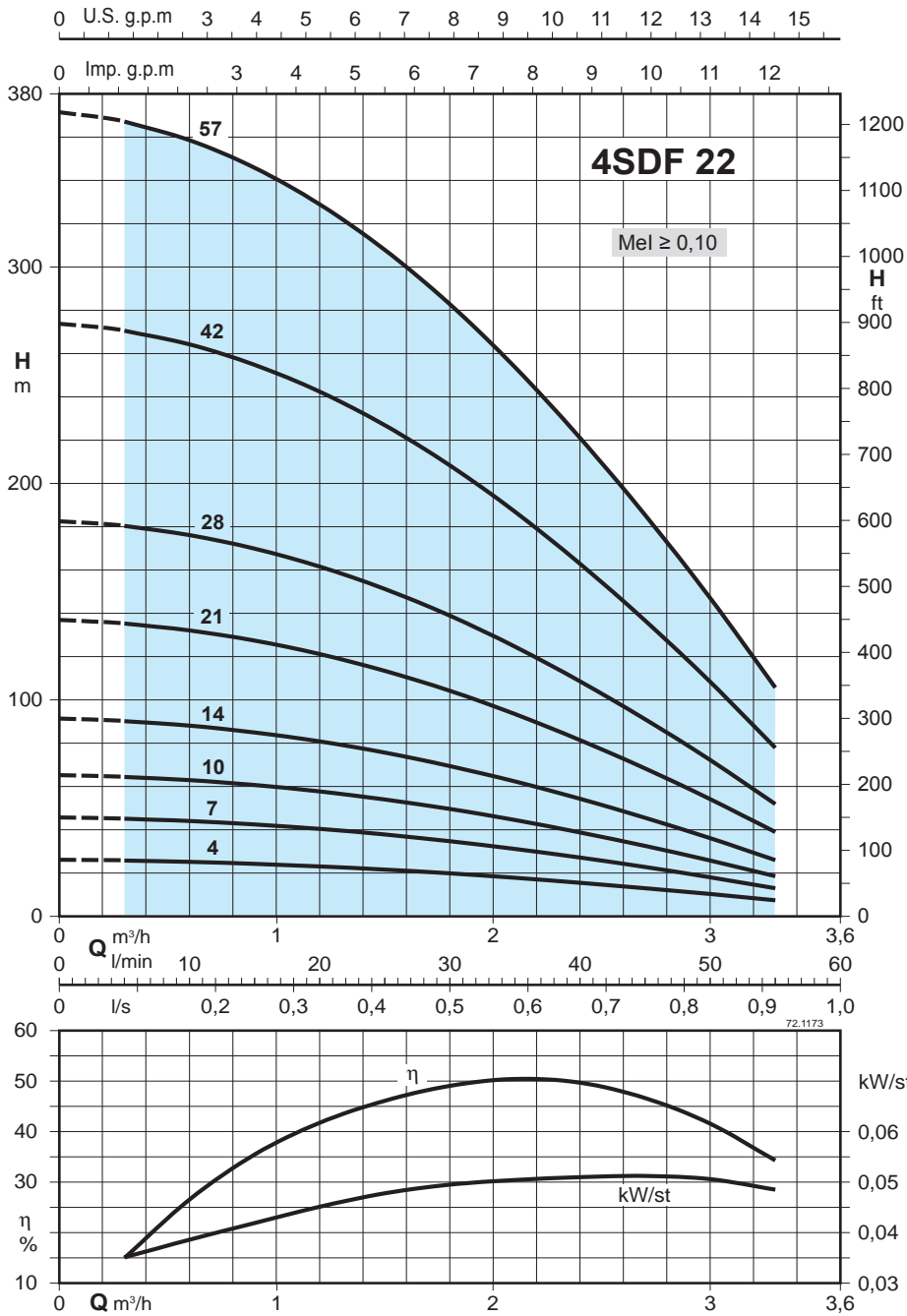

3~	400 V (380-415) 50 Hz	1~	230V *				P1	p2	Q	n \approx 2900 rpm												
			A	450 Vc	kW	kW				Hp	m ³ /h											
											0	0,3	0,6	0,9	1,2	1,5	1,8	2,4	3	3,3		
4SDF 22/4EC	1,2	4SDFM 22/4EC	3,2	16	0,62	0,37	0,5	H m	26,1	25,8	25,2	24,3	23,1	21,6	19,8	15,5	10,3	7,4				
4SDF 22/7EC	1,2	4SDFM 22/7EC	3,2	16	0,7	0,37	0,5		45,6	45,1	44	42,5	40,4	37,8	34,7	27,1	18	13				
4SDF 22/10EC	1,5	4SDFM 22/10EC	4	25	0,89	0,55	0,75		65,2	64,4	62,9	60,7	57,7	54	49,6	38,8	25,8	18,5				
4SDF 22/14EC	2	4SDFM 22/14EC	5,6	35	1,22	0,75	1		91,2	90,2	88,1	84,9	80,8	75,6	69,5	54,3	36,1	25,9				
4SDF 22/21EC	2,9	4SDFM 22/21EC	8,4	40	1,82	1,1	1,5		137	135	132	127	121	113	104	81,4	54,1	38,9				
4SDF 22/28EC	4,2	4SDFM 22/28EC	11,2	60	2,33	1,5	2		182	180	176	170	162	151	139	109	72,2	51,9				
4SDF 22/42EC	5,5	4SDFM 22/42EC	14,7	70	3,27	2,2	3		274	271	264	255	242	227	208	163	108	77,8				
4SDF 22/57EC	7,4					3	4		371	367	359	346	329	308	283	221	147	106				

L1	4SDF			4SDFM	
	L	L	kg	L	kg
265	592	10,6	592	10,6	
325	652	11,2	652	11,1	
385	732	10,7	747	13,4	
465	827	12,2	867	15,4	
605	1007	14,7	1052	18,5	
745	1192	17,4	1212	20,9	
1015	1417	28,4	1532	25,8	
1365	1846	33			

p1 Max. power input p2 Rated motor power output * Only for single-phase motor 230 V - 50 Hz (on request) tolerances according to Unl en ISO 9906:2012

Characteristic curves, performance $n \approx 2900$ rpm, dimensions and weights

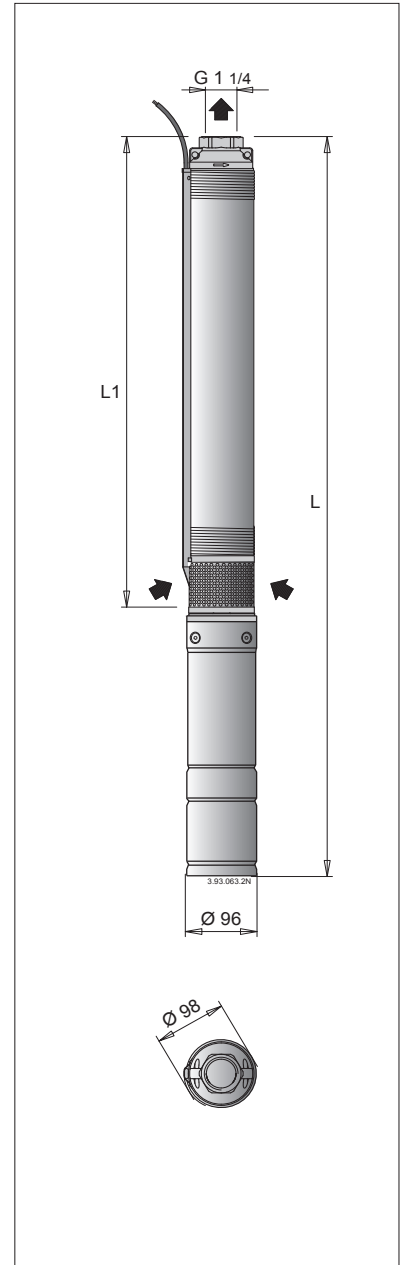
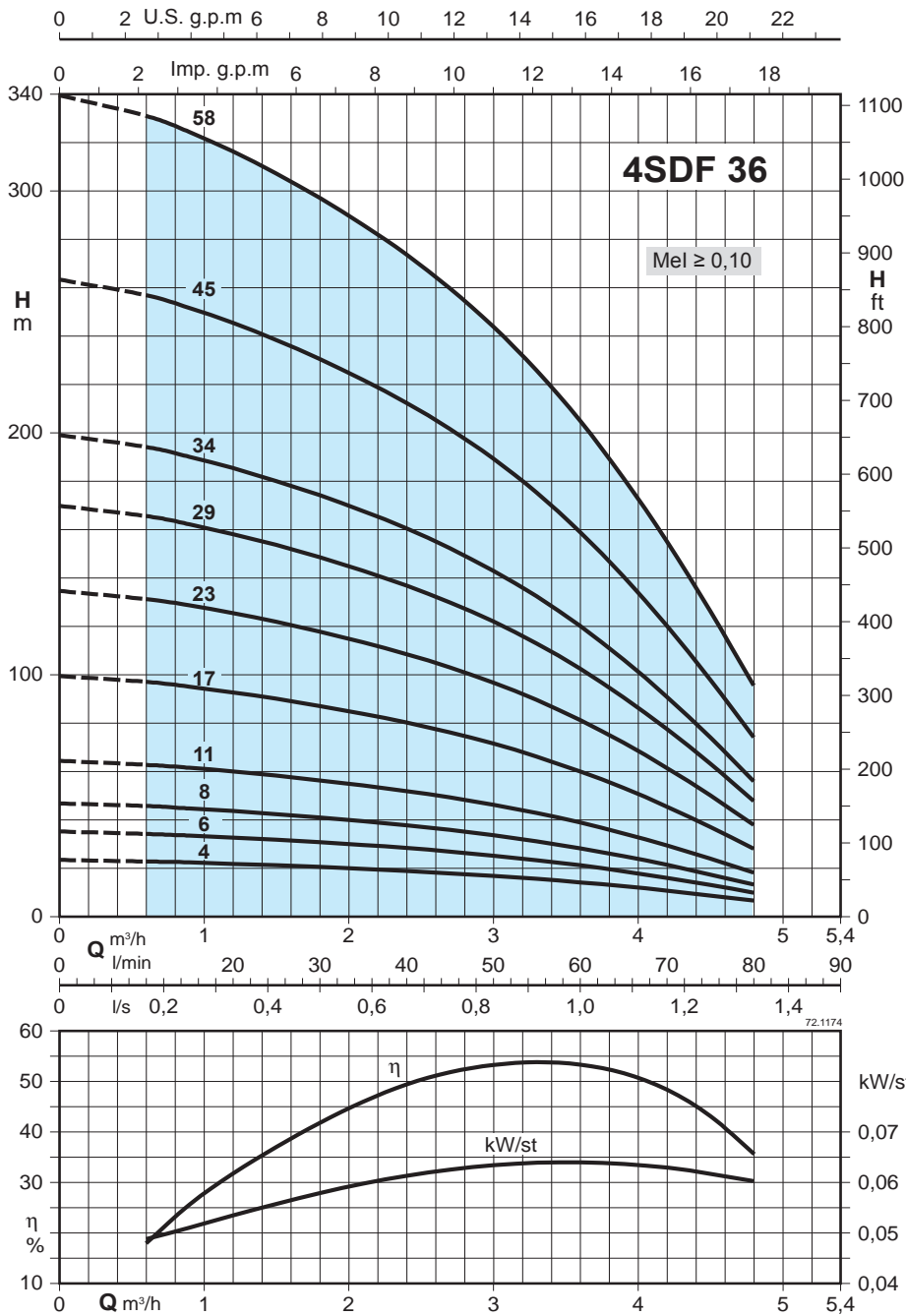

3~	400 V (380-415) 50 Hz	1~	230V	* P1			n ≈ 2900 rpm													
				A	450 Vc μF	kW	p2 kW	Hp	Q m³/h	Q										
										l/min	0	0,6	1,2	1,8	2,4	3	3,6	4,2	4,8	
4SDF 36/4EC	1,2	4SDFM 36/4EC	3,2	16	0,62	0,37	0,5	23,4	22,8	21,8	20,5	18,8	16,8	14,1	10,7	6,6				
4SDF 36/6EC	1,2	4SDFM 36/6EC	3,2	16	0,7	0,37	0,5	35,1	34,2	32,7	30,7	28,3	25,2	21,2	16	9,9				
4SDF 36/8EC	1,5	4SDFM 36/8EC	4	25	0,89	0,55	0,75	46,8	45,6	43,6	40,9	37,7	33,6	28,2	21,3	13,2				
4SDF 36/11EC	2	4SDFM 36/11EC	5,6	35	1,22	0,75	1	64,3	62,7	59,9	56,3	51,8	46,2	38,8	29,4	18,1				
4SDF 36/17EC	2,9	4SDFM 36/17EC	8,4	40	1,82	1,1	1,5	99,4	96,9	92,6	87	80,1	71,4	60	45,4	28				
4SDF 36/23EC	4,2	4SDFM 36/23EC	11,2	60	2,33	1,5	2	134	131	125	118	108	96,6	81,2	61,4	37,8				
4SDF 36/29EC	5,5	4SDFM 36/29EC	14,7	70	3,27	2,2	3	170	165	158	148	137	122	102	77,4	47,7				
4SDF 36/34EC	5,5	4SDFM 36/34EC	14,7	70	3,27	2,2	3	199	194	185	174	160	143	120	90,7	55,9				
4SDF 36/45EC	7,4					3	4	263	256	245	230	212	189	159	120	74				
4SDF 36/58EC	9,4					4	5,5	339	331	316	297	273	244	205	155	95,4				

L1 mm	4SDF		4SDFM	
	L mm	kg	L mm	kg
306	633	10,7	633	10,6
366	693	11,1	693	11
426	773	10,6	788	13,3
517	879	12,2	919	15,4
699	1101	14,7	1146	18,5
880	1327	17,5	1347	21
1063	1465	27,3	1580	24,7
1213	1694	28,7	1730	26,1
1590	2136	28,4		
1981	2627	34,3		

p1 Max. power input p2 Rated motor power output * Only for single-phase motor 230 V - 50 Hz (on request) tolerances according to Unl en ISO 9906:2012

Characteristic curves, performance $n \approx 2900$ rpm, dimensions and weights

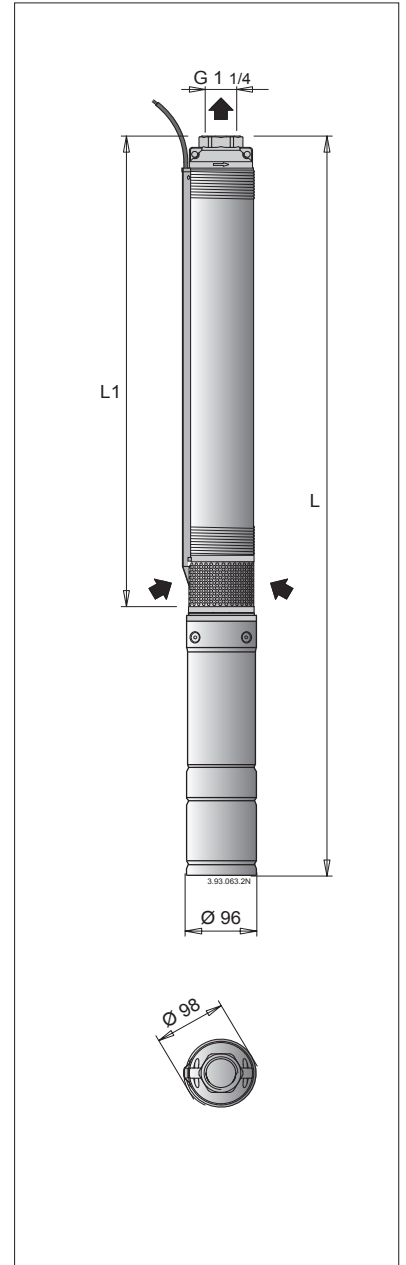
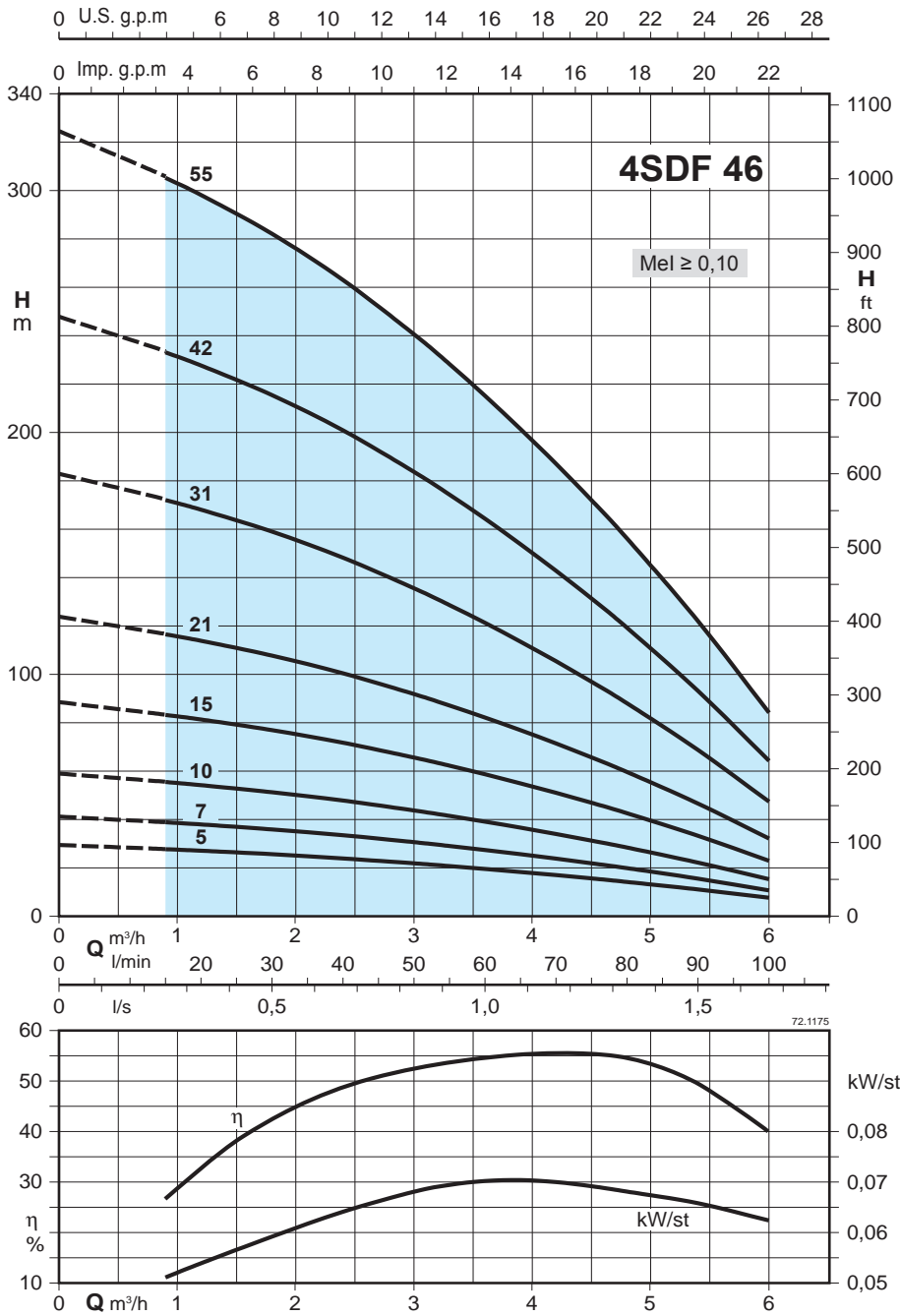

3~	400 V (380-415) 50 Hz	1~	230V	* P1			p2		Q m³/h l/min	n ≈ 2900 rpm												
				450 Vc		kW	kW	Hp		H m												
				A	μF					0	0,9	1,2	1,8	2,4	3	3,6	4,2	4,8	6			
4SDF 46/5EC	1,2	4SDFM 46/5EC	3,2	16	0,7	0,37	0,5	29,4	27,8	27,1	25,6	23,9	21,9	19,6	17	14,2	7,6	315	642	10,9	642	10,8
4SDF 46/7EC	1,5	4SDFM 46/7EC	4	25	0,89	0,55	0,75	41,2	38,9	37,9	35,9	33,5	30,6	27,4	23,8	19,9	10,7	370	717	10,4	732	13,1
4SDF 46/10EC	2	4SDFM 46/10EC	5,6	35	1,22	0,75	1	58,9	55,5	54,2	51,3	47,8	43,7	39,1	34	28,4	15,3	450	812	11,8	852	15
4SDF 46/15EC	2,9	4SDFM 46/15EC	8,4	40	1,82	1,1	1,5	88,3	83,3	81,3	76,9	71,7	65,6	58,7	51	42,6	22,9	585	987	14	1032	17,8
4SDF 46/21EC	4,2	4SDFM 46/21EC	11,2	60	2,33	1,5	2	124	117	114	108	100	91,9	82,2	71,4	59,6	32,1	740	1187	16,7	1207	20,2
4SDF 46/31EC	5,5	4SDFM 46/31EC	14,7	70	3,27	2,2	3	183	172	168	159	148	136	121	105	88	47,4	1005	1407	27,2	1522	24,6
4SDF 46/42EC	7,4					3	4	247	233	228	215	201	184	164	143	119	64,2	1340	1821	31,5		
4SDF 46/55EC	9,4					4	5,5	324	305	298	282	263	241	215	187	156	84,1	1685	2231	38,6		

L1 mm	4SDF		4SDFM	
	L mm	kg	L mm	kg
315	642	10,9	642	10,8
370	717	10,4	732	13,1
450	812	11,8	852	15
585	987	14	1032	17,8
740	1187	16,7	1207	20,2
1005	1407	27,2	1522	24,6
1340	1821	31,5		
1685	2231	38,6		

p1 Max. power input p2 Rated motor power output * Only for single-phase motor 230 V - 50 Hz (on request) tolerances according to Unl en ISO 9906:2012

Characteristic curves, performance $n \approx 2900$ rpm, dimensions and weights

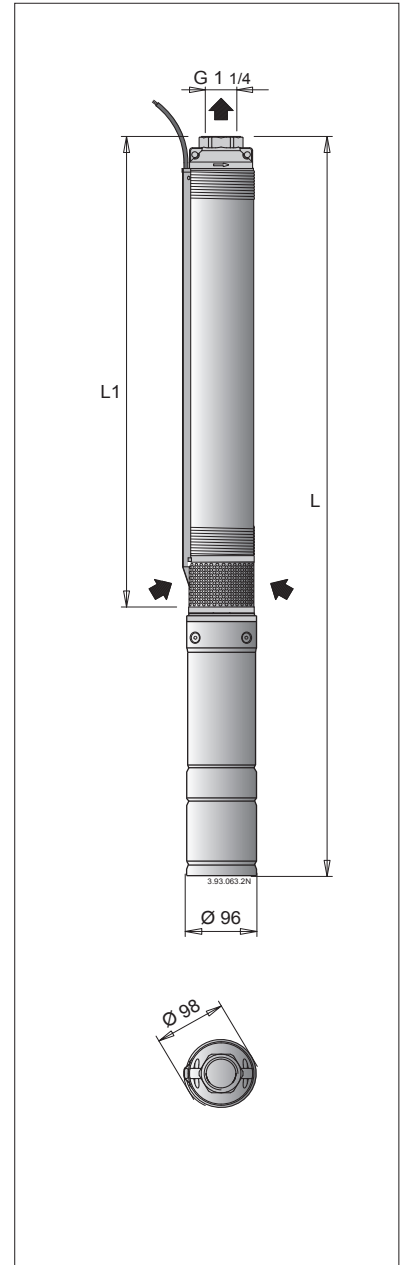
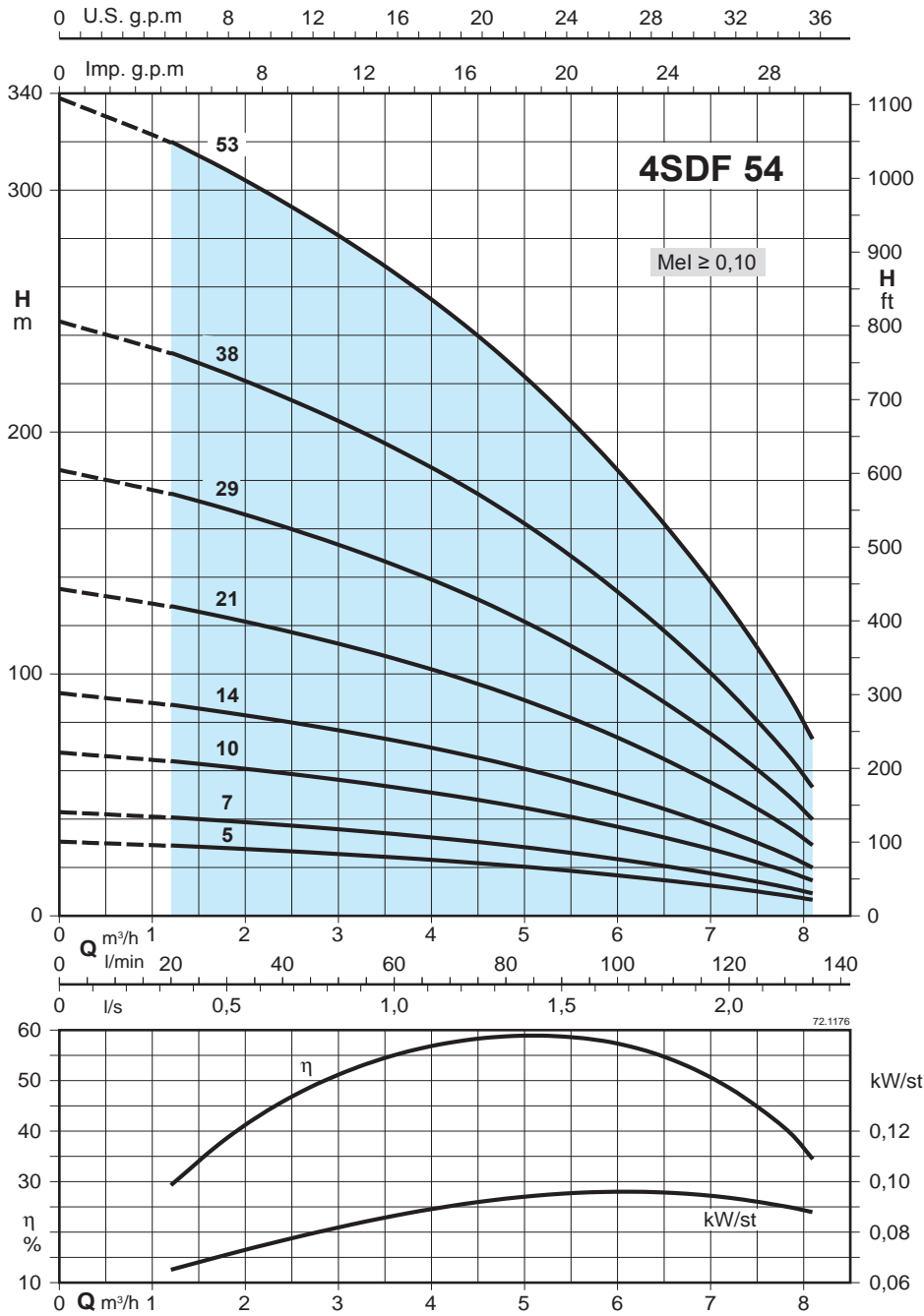

40

3~ 400 V (380-415) 50 Hz	1~ 230V	* P1		p2		Q m³/h l/min	n ≈ 2900 rpm										
		450 Vc		kW	Hp		0	1,2	1,8	2,4	3	3,6	4,8	6	7,2	8,1	
		A	µF				0	20	30	40	50	60	80	100	120	135	
4SDF 54/5EC	1,5	4SDFM 54/5EC	4	25	0,89	0,55	0,75	30,8	29,1	28	26,8	25,6	24,2	20,9	16,8	11,6	6,6
4SDF 54/7EC	2	4SDFM 54/7EC	5,6	35	1,22	0,75	1	43,1	40,7	39,2	37,6	35,8	33,8	29,3	23,5	16,3	9,3
4SDF 54/10EC	2,9	4SDFM 54/10EC	8,4	40	1,82	1,1	1,5	67,7	64	61,6	59,1	56,3	53,2	46	36,9	25,6	14,6
4SDF 54/14EC	4,2	4SDFM 54/14EC	11,2	60	2,33	1,5	2	92,3	87,3	84,1	80,5	76,7	72,5	62,7	50,3	34,8	19,9
4SDF 54/21EC	5,5	4SDFM 54/21EC	14,7	70	3,27	2,2	3	135	128	123	118	113	106	92	73,7	51,1	29,2
4SDF 54/29EC	7,4					3	4	185	175	168	161	153	145	125	101	69,7	39,9
4SDF 54/38EC	9,4					4	5,5	246	233	224	215	205	193	167	134	92,9	53,1
4SDF 54/53EC	13					5,5	7,5	338	320	308	295	281	266	230	184	128	73,1

L1 mm	4SDF		4SDFM	
	L mm	kg	L mm	kg
340	687	9,9	702	12,6
400	762	11,2	802	14,4
490	892	13	937	16,8
610	1057	15,4	1077	18,9
820	1222	25,4	1337	22,8
1060	1541	28,8		
1380	1926	35,6		
1830	2476	41,8		

p1 Max. power input p2 Rated motor power output * Only for single-phase motor 230 V - 50 Hz (on request) tolerances according to Unl en ISO 9906:2012

Characteristic curves, performance $n \approx 2900$ rpm, dimensions and weights

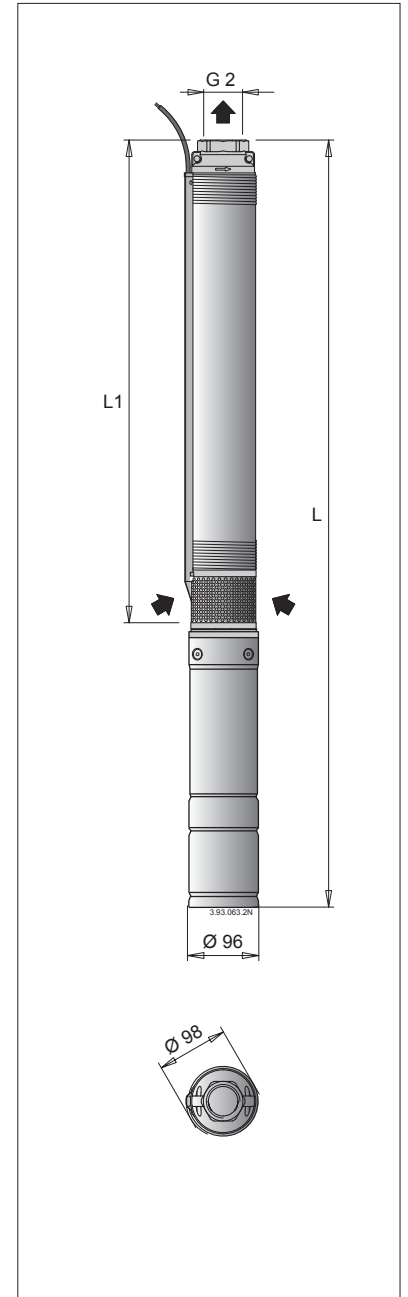
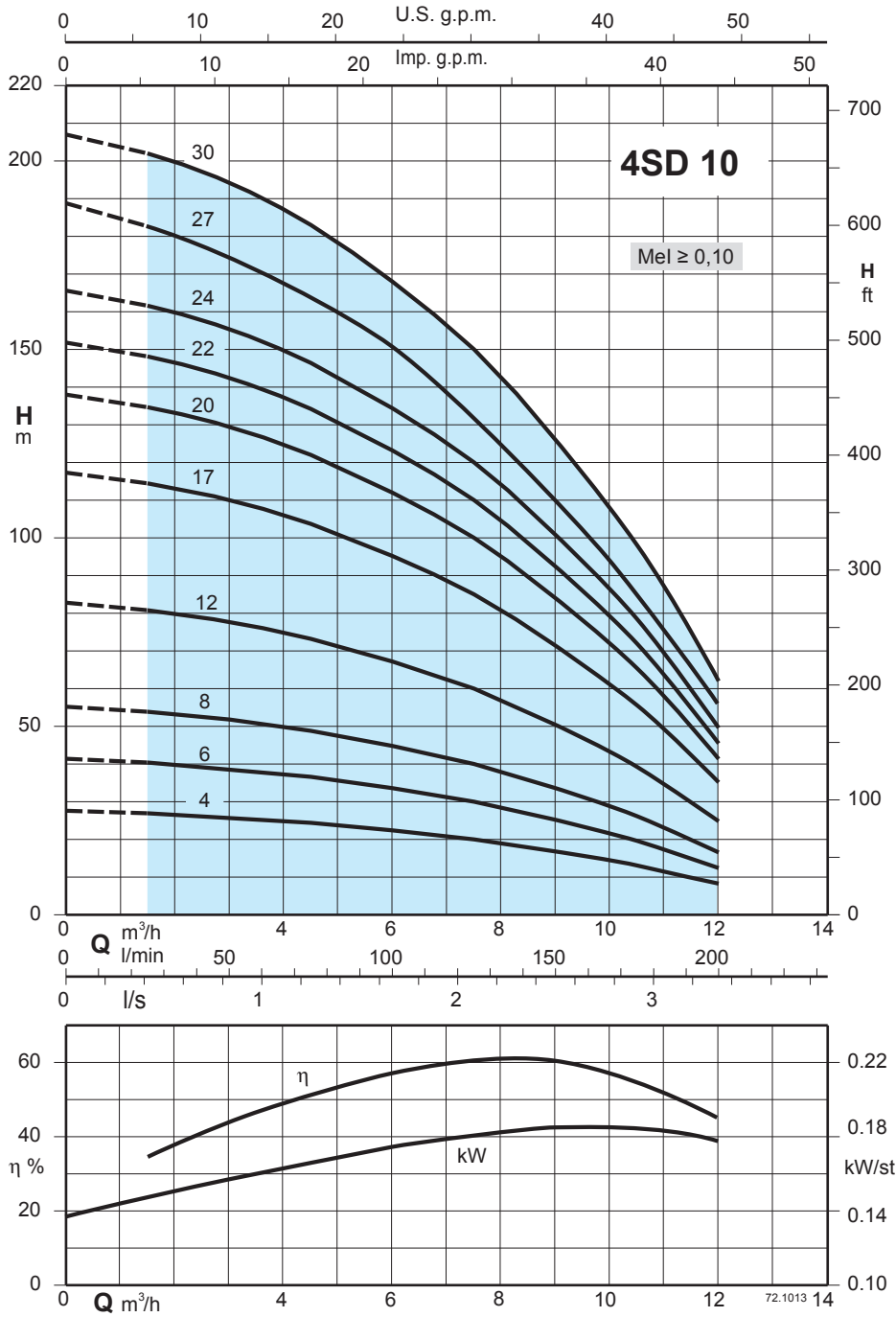

3~ 400 V (380-415) 50 Hz A	1~ 230V A	* 450 Vc μ F	P1 kW	p2 kW	Hp	n \approx 2900 rpm												
						Q m³/h	H m											
							1,5	2,4	3	3,6	4,8	6	7,2	8,4	9,6	10,8	12	
4SD 10/4EC	2	4SDM 10/4EC	5,6	35	1,22	0,75	1	27	26	26	25	24	23	20	18	15	12	8
4SD 10/6EC	2,9	4SDM 10/6EC	8,4	40	1,82	1,1	1,5	40	39	39	38	36	34	31	27	23	18	12
4SD 10/8EC	4,2	4SDM 10/8EC	11,2	60	2,33	1,5	2	54	53	52	51	48	45	41	36	30	25	16
4SD 10/12EC	5,5	4SDM 10/12EC	14,7	70	3,27	2,2	3	81	79	78	76	72	67	61	54	46	37	25
4SD 10/17EC	7,4					3	4	114	112	111	108	102	95	87	76	65	52	35
4SD 10/20EC	9,4					4	5,5	134	132	130	127	120	112	102	90	76	61	41
4SD 10/22EC	9,4					4	5,5	148	145	143	139	132	123	112	99	84	67	45
4SD 10/24EC	9,4					4	5,5	162	158	156	152	144	134	122	108	91	74	50
4SD 10/27EC	13					5,5	7,5	182	178	176	171	162	151	138	122	103	83	56
4SD 10/30EC	13					5,5	7,5	202	198	195	190	180	168	153	135	114	92	62

L1 mm	4SD		4SDM	
	L mm	kg	L mm	kg
409	771	11,6	811	14,1
515	917	13,4	962	16,7
621	1068	15,7	1088	18,6
833	1235	25,9	1350	22,7
1098	1579	28		
1312	1858	36		
1418	1964	36,8		
1524	2070	37,6		
1683	2329	41,1		
1842	2488	42,1		

p1 Max. power input p2 Rated motor power output * Only for single-phase motor 230 V - 50 Hz (on request) tolerances according to Unl en ISO 9906:2012

Characteristic curves, performance $n \approx 2900$ rpm, dimensions and weights

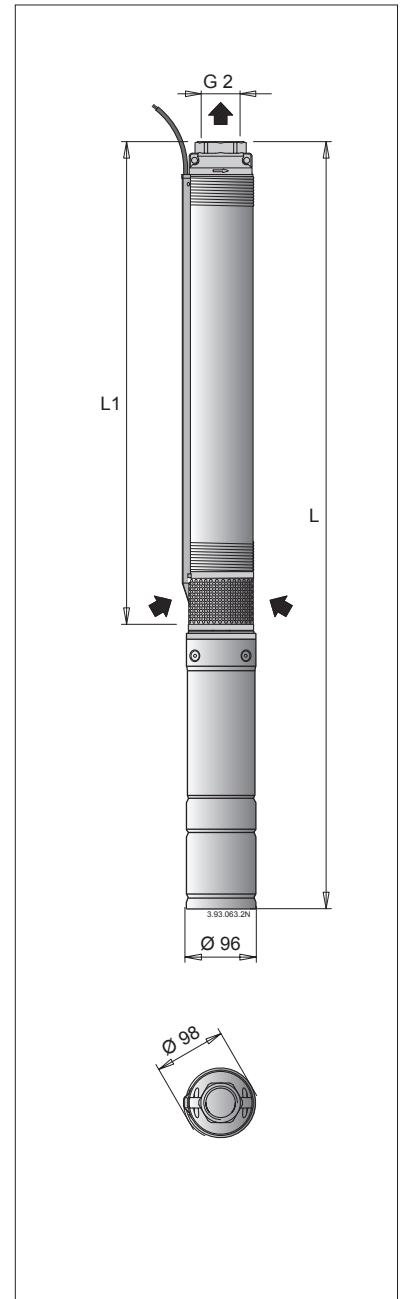
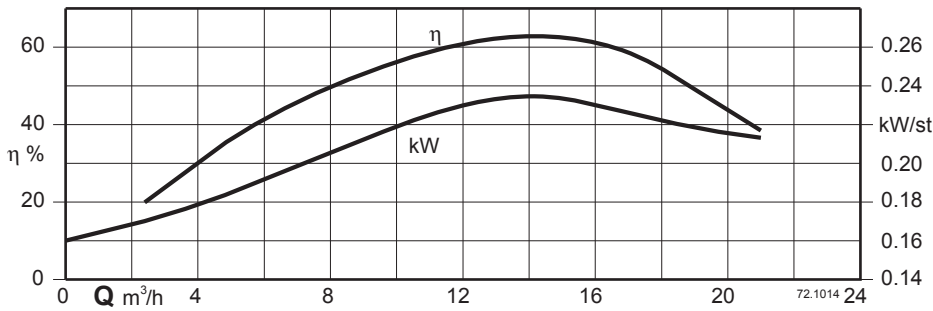
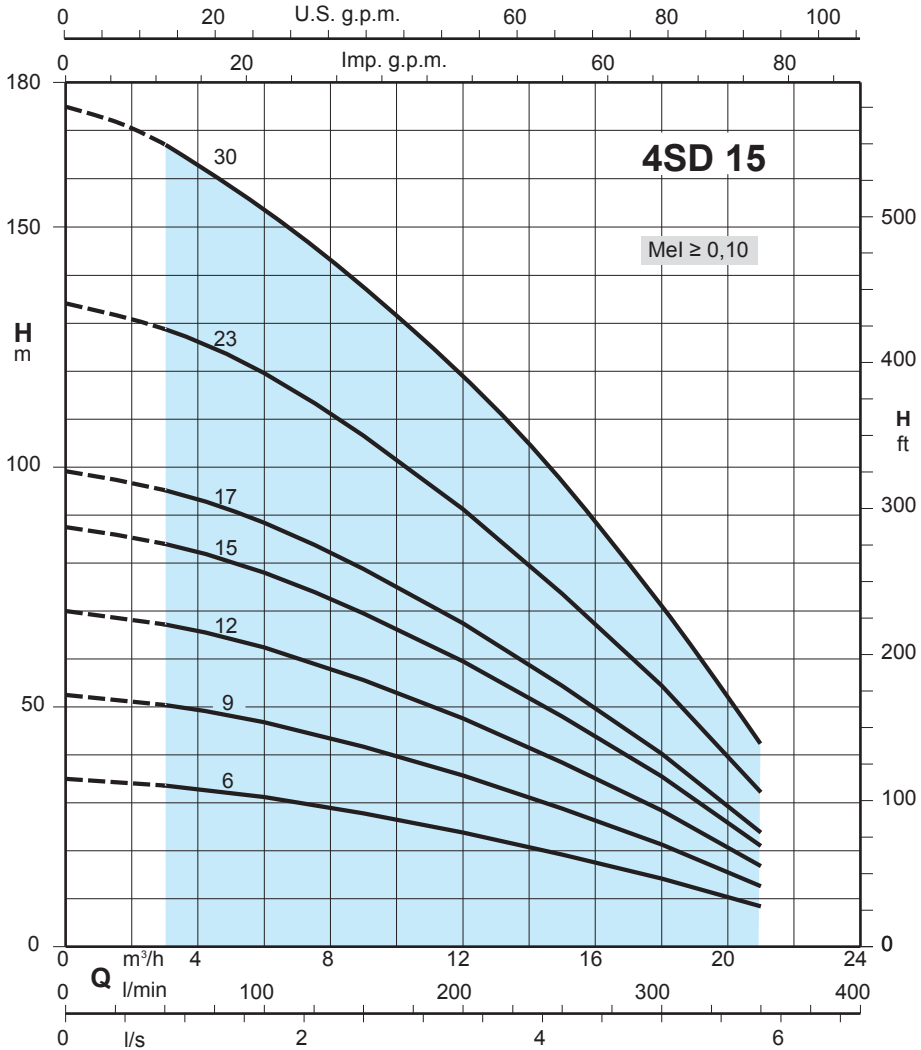

3~ 400 V (380-415) 50 Hz A	1~ 230V A	* 450 Vc µF	P1 kW	p2 kW	Hp	Q														L1 mm	4SD		4SDM	
						n ≈ 2900 rpm															L mm	kg	L mm	kg
						3	3,6	4,8	6	7,2	8,4	9,6	10,8	12	15	18	21	L	kg					
4SD 15/6EC	4,2	4SDM 15/6EC	11,2	60	2,33	1,5	2	33	33	32	31	30	29	28	26	24	19	14	8	755	1202	15,6	1222	18,5
4SD 15/9EC	5,5	4SDM 15/9EC	14,7	70	3,27	2,2	3	50	49	48	47	45	43	42	38	36	29	21	13	988	1390	33	1505	30,2
4SD 15/12EC	7,4					3	4	67	66	64	62	59	57	56	51	48	38	28	17	1299	1780	34,3		
4SD 15/15EC	9,4				4	5,5		84	83	81	78	74	71	69	64	59	48	35	21	1601	2147	40,6		
4SD 15/17EC	9,4				4	5,5		95	94	92	88	84	81	79	72	67	54	40	24	1756	2302	41,4		
4SD 15/23EC	13				5,5	7,5		129	127	124	120	114	109	107	98	91	74	54	32	2291	2937	49,4		
4SD 15/30E	18,8				7,5 ¹⁾	10 ¹⁾		168	166	162	156	149	142	140	128	119	97	70	42	2836	3610	62		

p1 Max. power input p2 Rated motor power output * Only for single-phase motor 230 V - 50 Hz (on request) tolerances according to Unl en ISO 9906:2012
1) Franklin motor

Characteristic curves, performance $n \approx 2900$ rpm, dimensions and weights

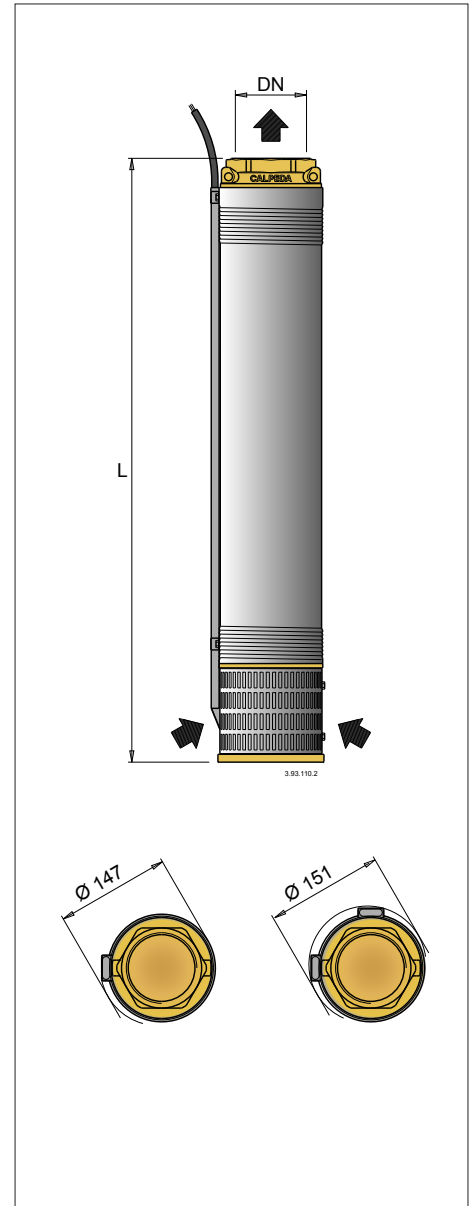
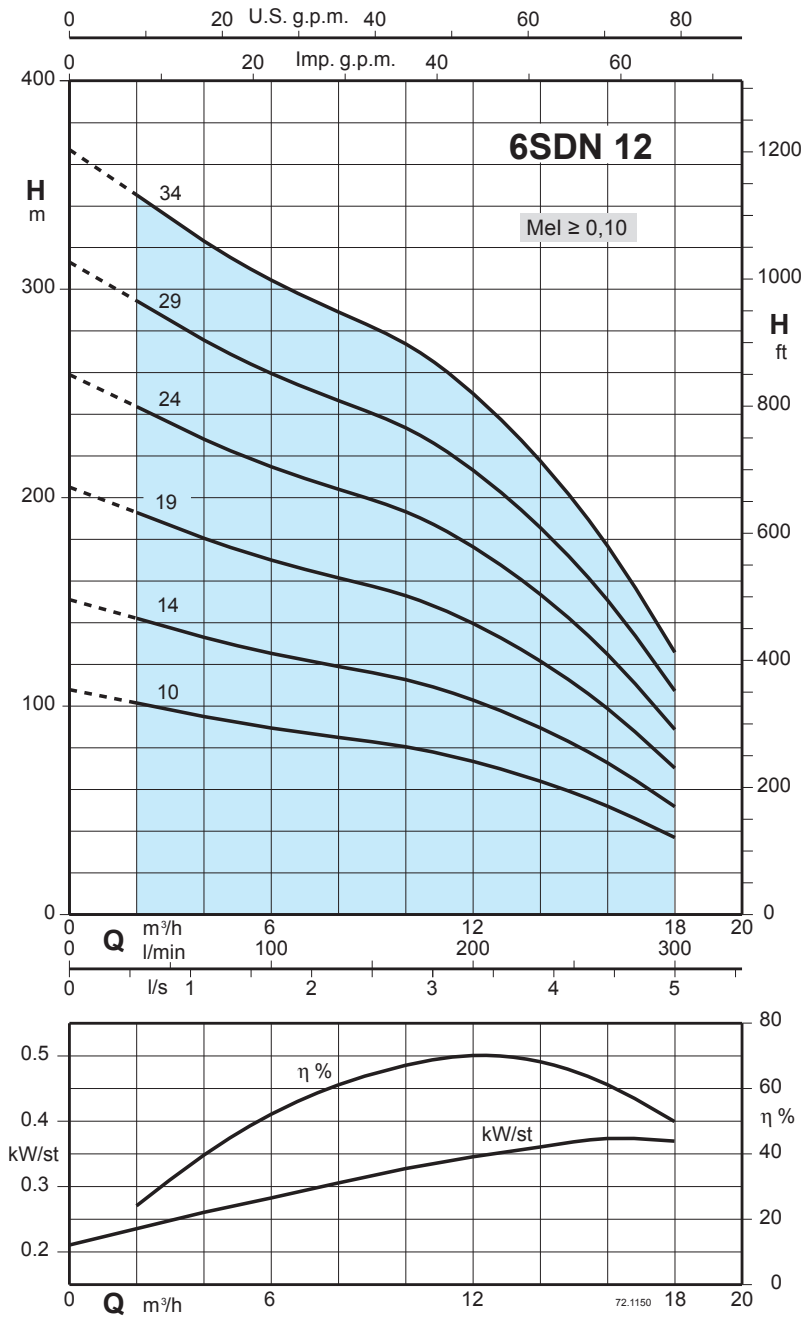

3~	p ₂		Q	n \approx 2900 rpm												
	kW	Hp		m ³ /h	2	4	6	8	10	12	14	16	18			
				l/min	33,3	66,6	100	133,3	166,6	200	233	266	300			
6SDn 12/10	4	5,5	H m	102	95	89,5	85	80,5	73,5	64	52	37				
6SDn 12/14	5,5	7,5		142	133	125	119	113	103	89,5	73	52				
6SDn 12/19	7,5	10		193	181	170	162	153	140	122	99	70,5				
6SDn 12/24	9,2	12,5		244	231	215	204	193	176	154	125	89				
6SDn 12/29	11	15		294	276	260	247	233	213	186	151	107				
6SDn 12/34	13 (15)	17,5 (20)		345	323	304	289	274	250	218	177	126				

Dn	L	
	mm	kg
G 3 ISO 228	715	15,5
	870	17,5
	1060	20
	1320	23
	1510	25,7
	1705	28,5

p₂ Rated motor power output

(...) FK motor rated power output

H total head in m

tolerances according to Unl en ISO 9906:2012

Characteristic curves, performance $n \approx 2900$ rpm, dimensions and weights

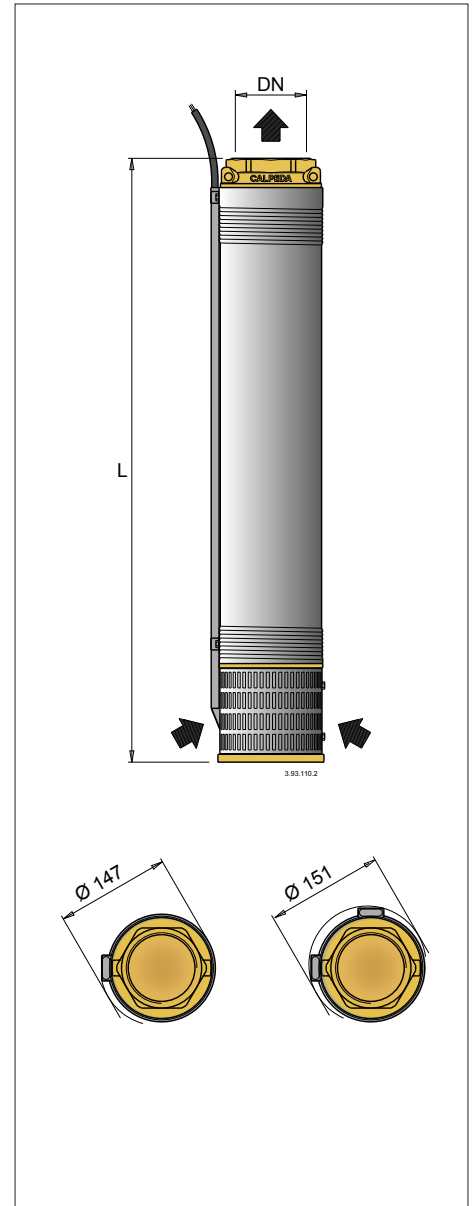
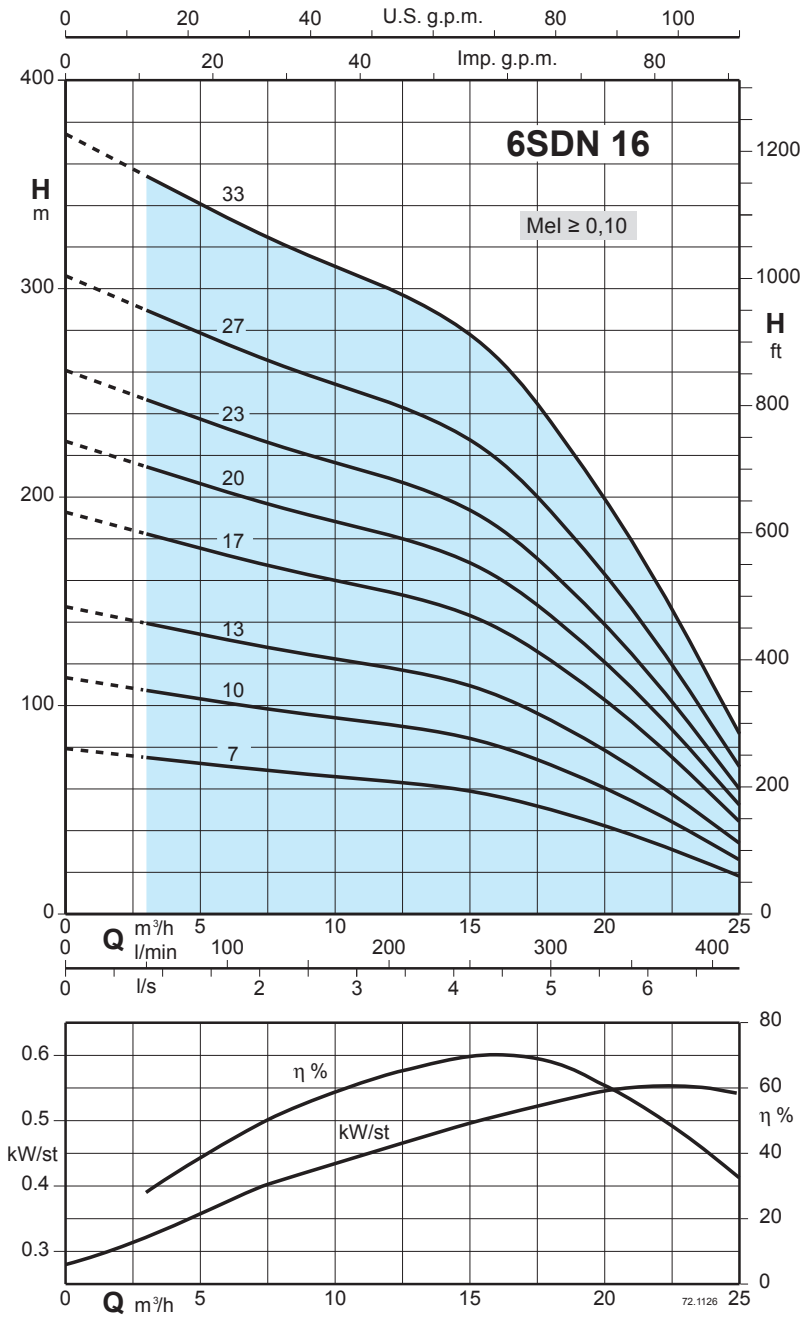

3~	p ₂		Q	n ≈ 2900 rpm											
	kW	Hp	m³/h	3	6	9	12	15	18	21	25				
			l/min	50	100	150	200	250	300	350	416,6				
		H m		75	71	67	63,5	59	50	38	18,5				
6SDn 16/7	4		5,5	107	101	96	91	84	71,5	54,5	26				
6SDn 16/10	5,5		7,5	139	132	124	118	110	93	70,5	34				
6SDn 16/13	7,5		10	182	172	163	155	143	122	92,5	44,5				
6SDn 16/17	9,2		12,5	215	202	192	182	168	143	109	52,5				
6SDn 16/20	11		15	247	233	220	209	194	165	125	60				
6SDn 16/23	13 (15)		17,5 (20)	290	273	259	245	227	193	147	71				
6SDn 16/27	15		20	354	334	316	300	278	236	179	86,5				
6SDn 16/33	18,5	25													

Dn	L	
	mm	kg
G 3 ISO 228	600	14
	715	15,5
	830	17
	985	19
	1100	20,5
	1285	22,5
	1435	24,6
	1665	28

p₂ Rated motor power output

(...) FK motor rated power output

H total head in m

tolerances according to Unl en ISO 9906:2012

Characteristic curves, performance $n \approx 2900$ rpm, dimensions and weights

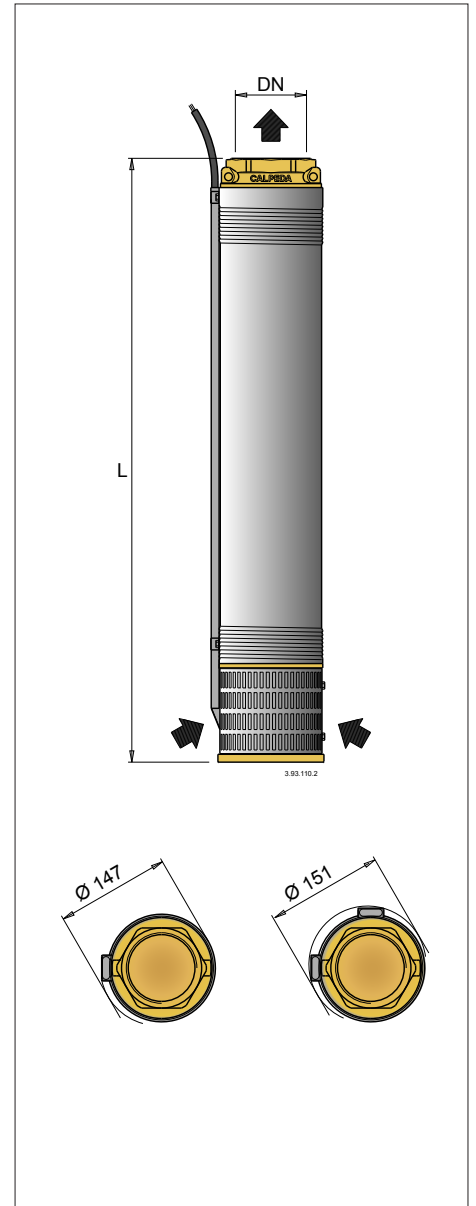
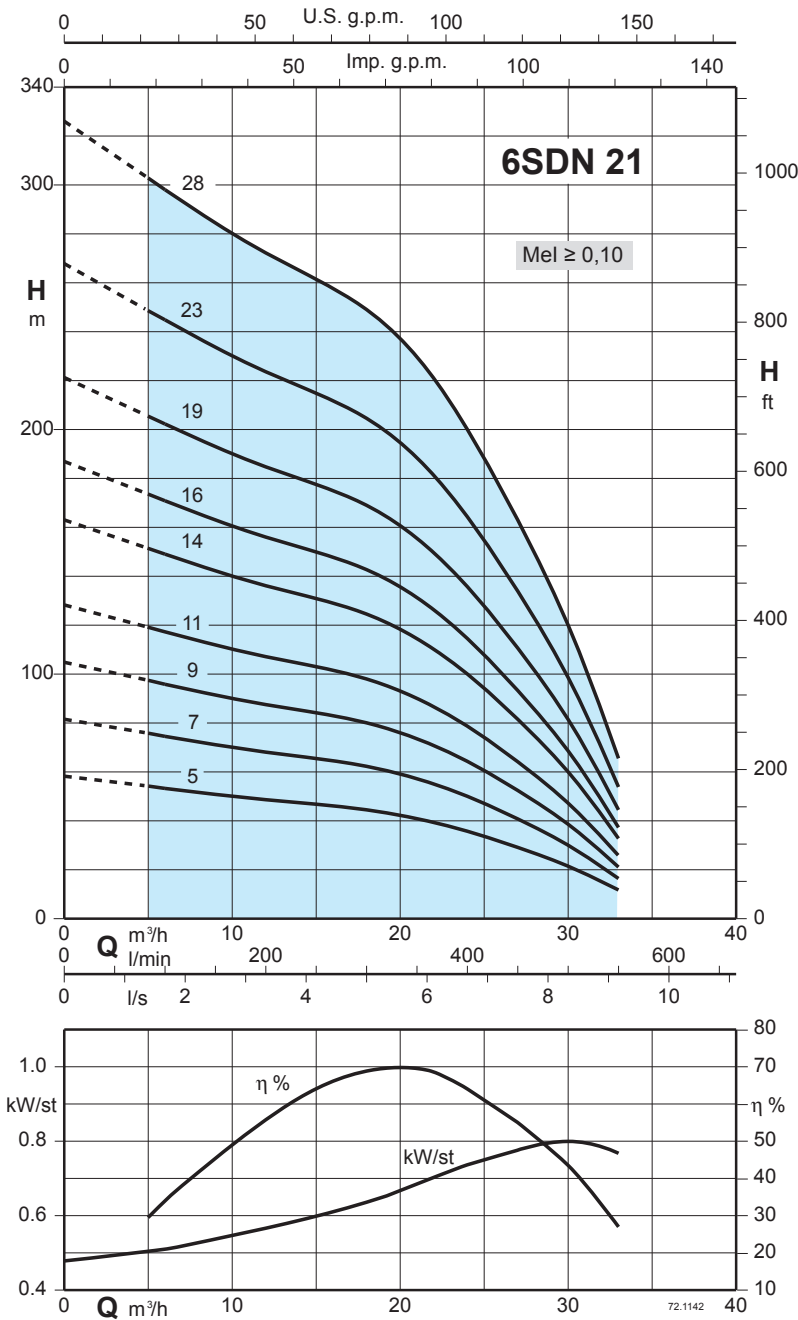

3~	p2		Q	n \approx 2900 rpm											
	kW	Hp		H m											
				5	9	12	15	18	21	24	27	30	33		
6SDn 21/5	4	5,5	83,3	54	51	48,5	46,5	45	41,5	36	29	21,5	11,5		
6SDn 21/7	5,5	7,5	150	75,5	71,5	68	65	62,5	58	50	41	30	16		
6SDn 21/9	7,5	10	200	97	92	87,5	83,5	80,5	74,5	64,5	53	38,5	21		
6SDn 21/11	9,2	12,5	250	119	112	107	102	99	91	79	64	47	25,5		
6SDn 21/14	11	15	300	151	143	136	130	125	116	100	81,5	60	32,5		
6SDn 21/16	13 (15)	17,5 (20)	350	173	163	155	149	143	132	114	93	69	37		
6SDn 21/19	15	20	400	205	194	185	176	170	157	136	111	81,5	44		
6SDn 21/23	18,5	25	450	249	235	224	213	206	190	164	134	99	53		
6SDn 21/28	22	30	500	303	286	272	260	251	231	200	163	120	64,5		

Dn	L	
	mm	kg
G 3 ISO 228	565	13,3
	660	14,5
	755	15,7
	850	16,9
	990	18,7
	1085	19,9
	1225	21,7
	1480	24,5
	1710	27,5

p2 Rated motor power output

(...) FK motor rated power output

H total head in m

tolerances according to Unl en ISO 9906:2012

Characteristic curves, performance $n \approx 2900$ rpm, dimensions and weights

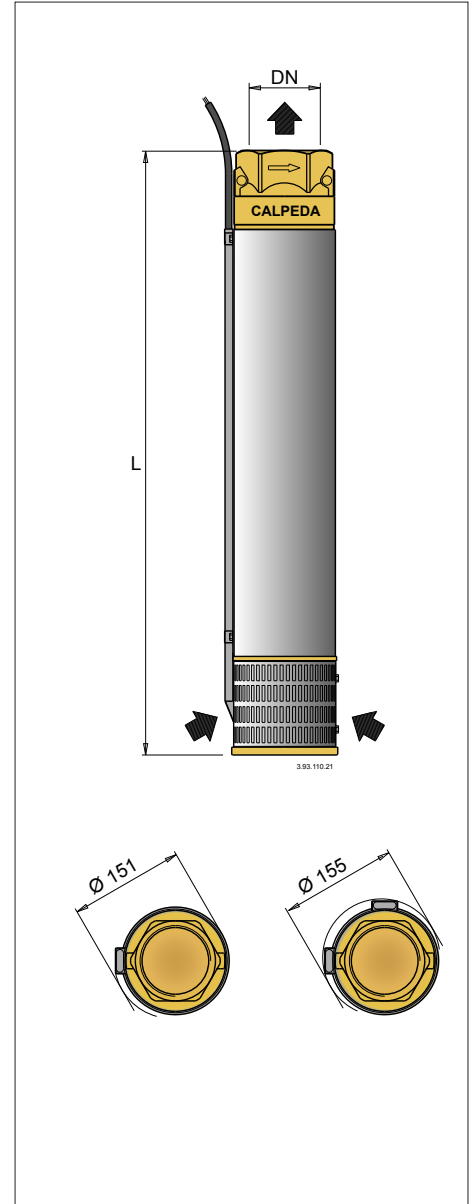
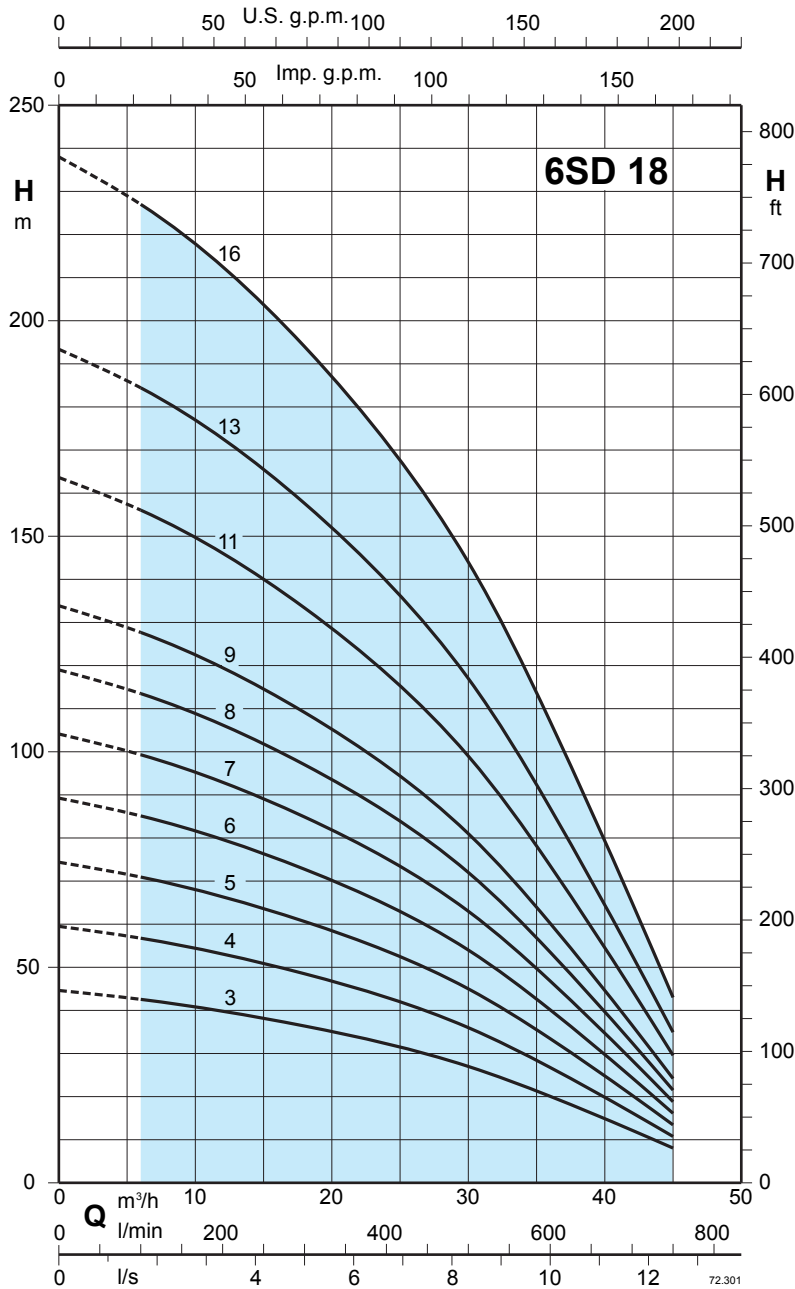

3 ~	p ₂		Q	n ≈ 2900 rpm													
	kW	Hp		H													
				m													
6SD 18/3	4	5,5	l/min	100	200	300	400	500	600	700	750						
6SD 18/4	5,5	7,5		42	39	36	32	27	20	12	8						
6SD 18/5	7,5	10		56	53	48	43	36	27	16	11						
6SD 18/6	9,2	12,5		70	66	60	53	45	34	21	13						
6SD 18/7	9,2	12,5		85	79	72	64	54	40	25	16						
6SD 18/8	11	15		100	93	84	75	63	46	28	19						
6SD 18/9	13 (15)	17,5 (20)		113	105	96	86	72	54	32	21						
6SD 18/11	15	20		127	119	108	96	81	60	37	24						
6SD 18/13	18,5	25		156	145	132	118	99	74	45	30						
6SD 18/16	22	30		184	172	157	139	117	87	52	35						
				227	213	194	172	144	107	65	43						

Dn	L	
	mm	kg
G 3 ISO 228	647	20,5
	756	23
	865	25
	974	27
	1083	29,5
	1192	32
	1301	34,5
	1519	39,5
	1737	43
	2064	50,2

p₂ Rated motor power output

(...) FK motor rated power output

H total head in m

tolerances according to Unl en ISO 9906:2012

Characteristic curves, performance $n \approx 2900$ rpm, dimensions and weights

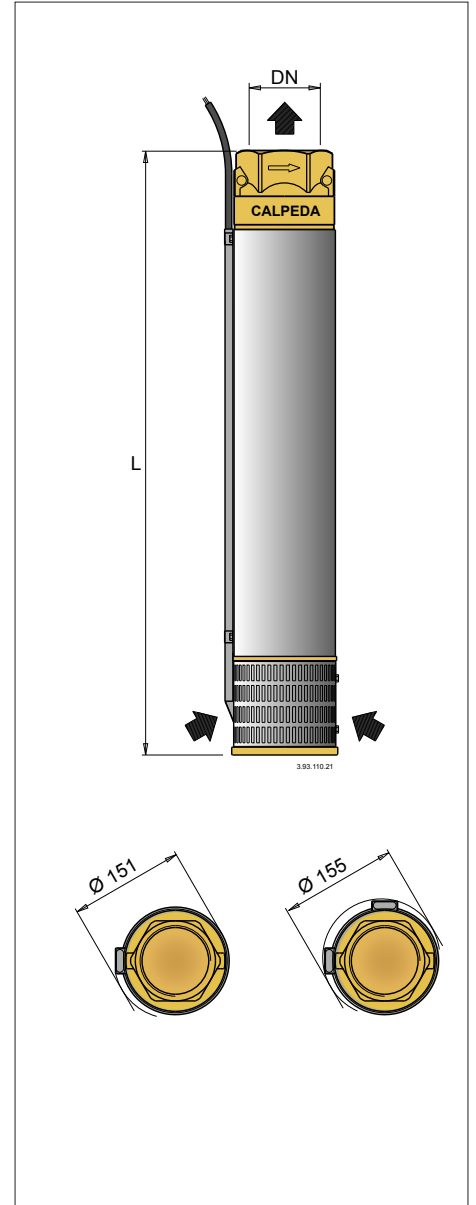
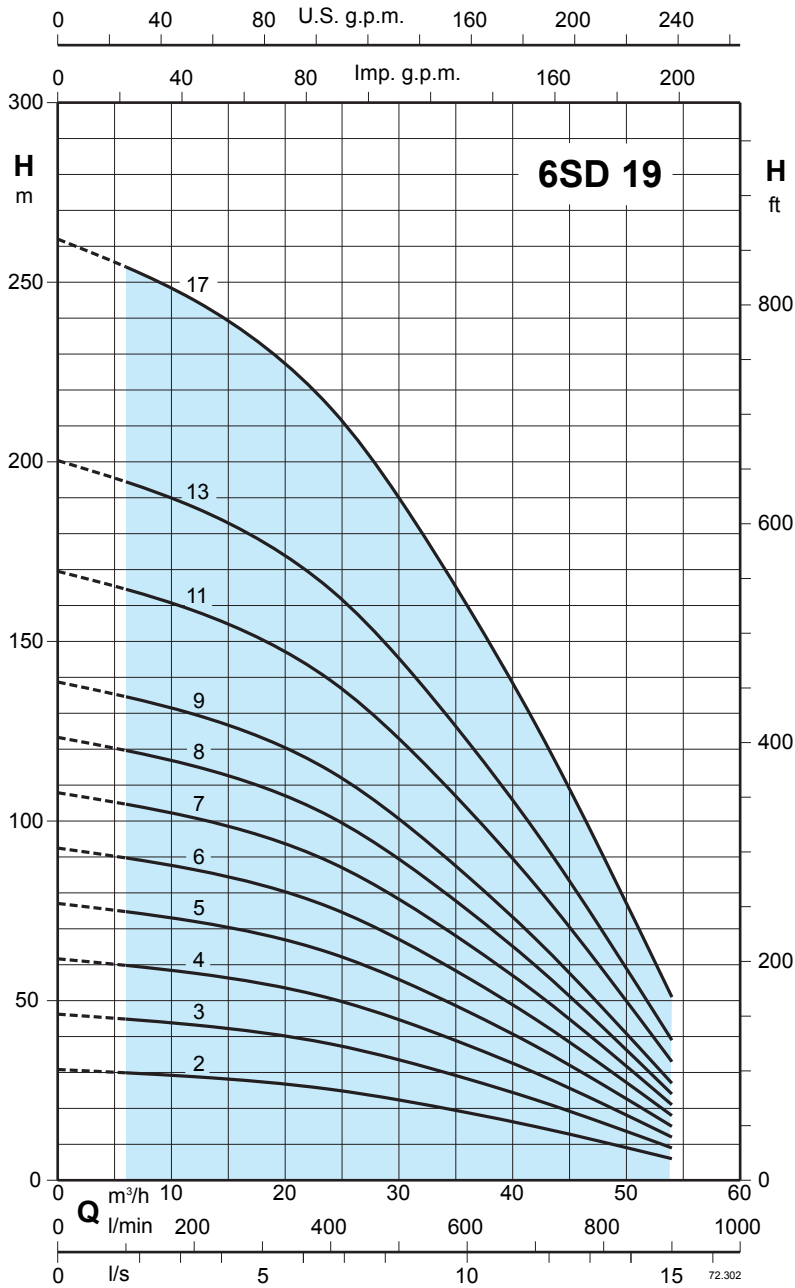

3 ~	p2		Q	$n \approx 2900$ rpm												
	kW	Hp		m³/h	6	12	18	24	30	36	42	48	54			
			l/min	100	200	300	400	500	600	700	800	900				
6SD 19/2	4	5,5	H m	30	29	27	25	22	19	15	10	6				
6SD 19/3	5,5	7,5		45	43	41	38	33	29	23	15	9				
6SD 19/4	7,5	10		60	57	55	50	45	38	30	21	12				
6SD 19/5	9,2	12,5		75	72	69	63	56	47	38	26	15				
6SD 19/6	11	15		90	86	82	75	67	56	45	31	18				
6SD 19/7	13 (15)	17,5 (20)		105	100	96	88	79	66	53	37	21				
6SD 19/8	15	20		120	115	110	101	89	75	60	42	24				
6SD 19/9	15	20		135	130	123	114	100	85	68	47	27				
6SD 19/11	18,5	25		165	158	151	139	123	104	83	58	33				
6SD 19/13	22	30		195	188	179	164	145	122	98	69	39				
6SD 19/17	30	40		255	245	234	215	190	160	127	90	51				

Dn	L	
	mm	kg
G 3 ISO 228	538	18
	647	20,5
	756	23
	865	25
	974	27
	1083	29,5
	1192	32
	1301	34,5
	1519	39,5
	1737	43
	2173	53

p2 Rated motor power output

(...) FK motor rated power output

H total head in m

tolerances according to Unl en ISO 9906:2012

Characteristic curves, performance $n \approx 2900$ rpm, dimensions and weights

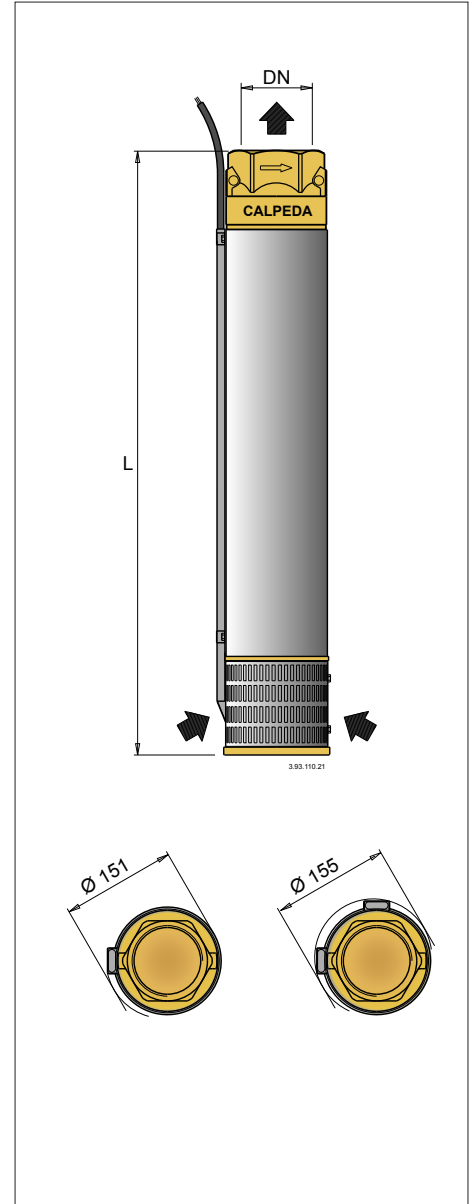
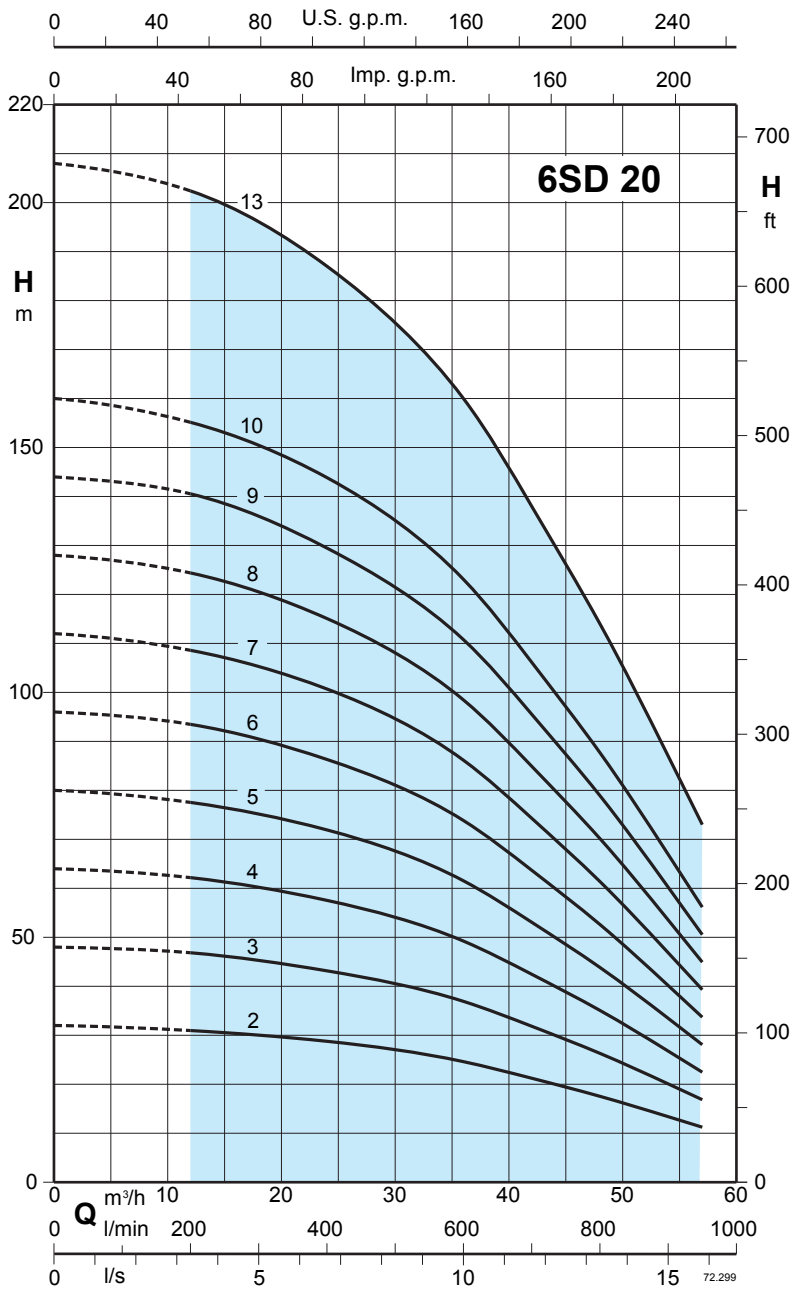

3 ~	p2		Q	n ≈ 2900 rpm										
	kW	Hp		H										
				12	18	24	30	36	42	48	54	57		
6SD 20/2	5,5	7,5	31	30	29	28	24	21	17	13	11			
6SD 20/3	7,5	10	46	45	44	42	37	32	26	20	17			
6SD 20/4	9,2	12,5	62	60	58	55	49	42	35	26	22			
6SD 20/5	11	15	77	76	73	68	61	53	44	33	28			
6SD 20/6	13 (15)	17,5 (20)	93	91	87	83	73	63	53	40	34			
6SD 20/7	15	20	108	106	102	96	86	74	61	47	39			
6SD 20/8	18,5	25	124	120	115	110	99	85	70	53	45			
6SD 20/9	18,5	25	140	136	130	124	111	96	79	60	51			
6SD 20/10	22	30	155	151	144	138	123	106	88	67	56			
6SD 20/13	30	40	202	196	188	179	160	138	114	87	73			

Dn	L1	
	mm	kg
G 3 ISO 228	538	18
	647	20,5
	756	23
	865	25
	974	27
	1083	29,5
	1192	32
	1301	34,5
1410	36,2	
1737	44,4	

p2 Rated motor power output

(...) FK motor rated power output

H total head in m

tolerances according to Unl en ISO 9906:2012