



Construction

Close-coupled centrifugal pumps with open impeller. The built-in backflow preventer avoids reverse siphoning when the pump is stopped and assures automatic re-priming at the next start. The pump re-priming itself even if partially filled with liquid and with completely empty suction pipe.
 A: version with pump casing and lantern bracket in cast iron.
 B-A: version with pump casing and lantern bracket in bronze (the pumps are supplied fully painted).

Applications

For clean or slightly dirty water, also with solids up to 10 mm grain size for A 40, A 50 and 15 mm for A 65, A 80. For draining a basin or a sump. For irrigation. For civil and industrial applications.

Operating conditions

Liquid temperature from -10 °C to +90 °C. Room temperature up to 40 °C. Maximum permissible working pressure up to 6 bar (10 bar for A 80-170). Continuous duty.

Motor

2-pole induction motor, 50 Hz (n ≈ 2900 rpm).
A three-phase 230/400 V ± 10% up to 3 kW; 400/690 V ± 10% from 4 to 7,5 kW;
AM: single-phase 230 V ± 10%, with thermal protector. Capacitor inside the terminal box.
 Insulation class F. Protection IP 54.

Classification scheme IE2 for three-phase motors from 0,75 kW.
 Constructed in accordance with: EN 60034-1; EN 60034-30. EN 60335-1, EN 60335-2-41.

Special features on request

Other voltages. Frequency 60 Hz (as per 60 Hz data sheet). Protection IP 55. Special mechanical seal. Higher or lower liquid or ambient temperatures. Explosion proof construction in accordance with Directive 94/9 EEC (ATEX). Construction with bearing bracket.

Materials

Components	A	B-A
Pump casing Suction flange Inspection cover (for A 65, A 80) Lantern bracket Impeller	Cast iron G.JL 200 EN 1561	Bronze G-Cu Sn 10 EN 1982
Shaft	Chrome-nickel steel 1.4305 EN 10088 (AISI 303) Chrome steel 1.4104 EN 10088 (AISI 430) for A 65-150	Cr-Ni-Mo steel 1.4401 EN 10088 (AISI 316)
Mechanical seal	Carbon - Ceramic - NBR	

Coverage chart n ≈ 2900 rpm

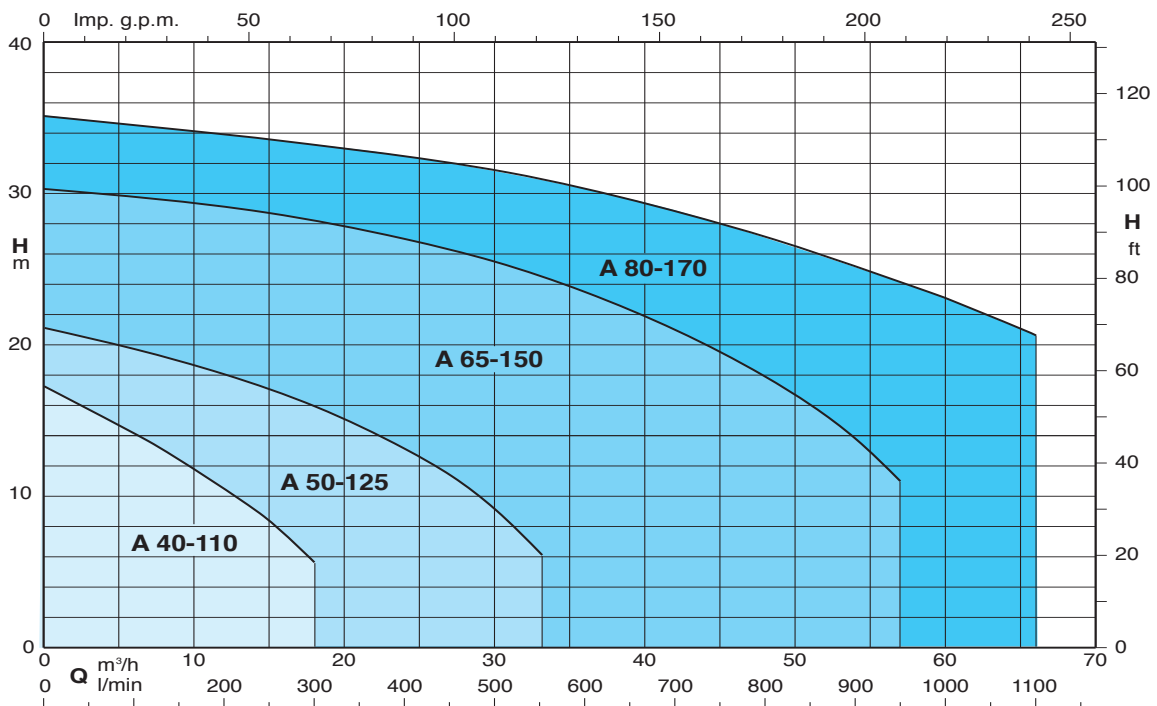



Performance n ≈ 2900 rpm

3 ~	230 V 400 V		1 ~	230 V		P ₁		P ₂		Q	H _m									
	A	A		A	kW	HP	kW	HP	m ³ /h		l/min	3,6	4,8	6	7,5	8,4	9,6	10,8	12	15
A 40-110B/A B-A 40-110B/A	2,8	1,6	AM 40-110B/A B-AM 40-110B/A	4,5	0,85	0,55	0,75	H _m	12,9	12,4	11,8	11	10,4	9,8	9	8,3	6	3,4		
A 40-110A/A B-A 40-110A/A	3,7	2,2	AM 40-110A/A B-AM 40-110A/A	6	1,1	0,75	1		15,4	14,9	14,2	13,3	12,9	12,1	11,3	10,5	8,4	5,6		

3 ~	230 V 400 V		1 ~	230 V		P ₁		P ₂		Q	H _m										
	A	A		A	kW	HP	kW	HP	m ³ /h		l/min	6	9	12	15	18	21	24	27	30	33
A 50-125CE B-A 50-125CE	3,3	1,9	AM 50-125CE B-AM 50-125CE	5,8	1,2	0,75	1	H _m	12,8	12,2	11,3	10	8,5	7	5,3	3,3					
A 50-125BE B-A 50-125BE	4,7	2,7	AM 50-125BE B-AM 50-125BE	7,4	1,6	1,1	1,5		15,5	14,9	14,2	12,9	11,6	10	8,3	6,2	4				
A 50-125AE B-A 50-125AE	7,5	4,3	AM 50-125AE B-AM 50-125AE	9,2	2,1	1,5	2	19,5	19	18	17	15,5	14	12,5	10,5	8	5				

3 ~	230 V 400 V		P ₂	P ₂		Q	H _m														
	A	A		kW	HP		m ³ /h	l/min	15	18	24	30	33	36	42	48	54	57			
A 65-150C/B B-A 65-150C/A	11,5	6,6	2,2	3	H _m	17,5	17	16	14	13	11,5	9	6,5								
A 65-150B/B B-A 65-150B/A	11,5	6,6				21,5	21	19,5	17,5	16,5	15,5	12,5	9,5	6,5							
A 65-150A/B B-A 65-150A/A	-	9,6	4	5,5	29	28	27	25,5	24,5	23,5	21	18	14	11							

3 ~	230 V 400 V		P ₂	P ₂		Q	H _m															
	A	A		kW	HP		m ³ /h	l/min	15	18	21	24	30	36	45	54	60	66				
A 80-170B/A B-A 80-170B/A	-	10,9	5,5	7,5	H _m	27,3	27,3	27	26,8	25,7	24,4	22,1	19	16,7	13,7							
A 80-170A/A B-A 80-170A/A	-	14,3				33,6	33,2	32,9	32,5	31,6	30,5	28,1	25,3	23,2	20,4							

P₁ Maximum power input. P₂ Rated motor power output. H Total head in m. B-A, B-AM = Bronze construction. Tolerances according to UNI EN ISO 9906:2012

Self-priming Capability

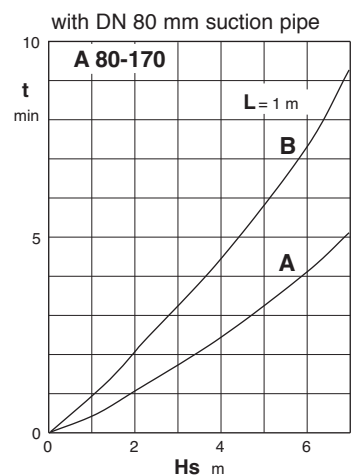
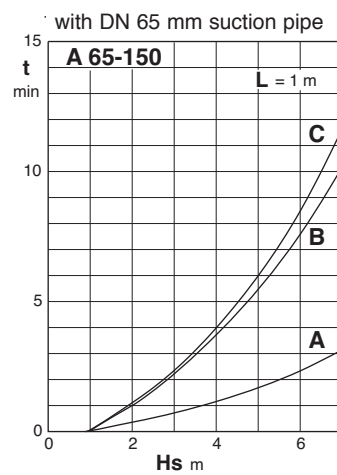
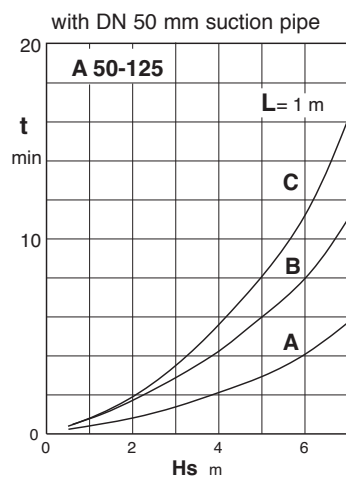
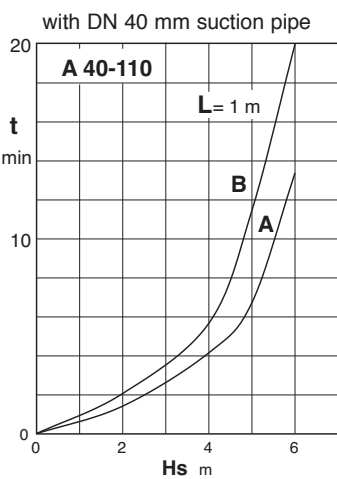

H_s (m) Suction lift.

L (m) Horizontal length of suction pipe above the water level.

t (min) Self-priming time.

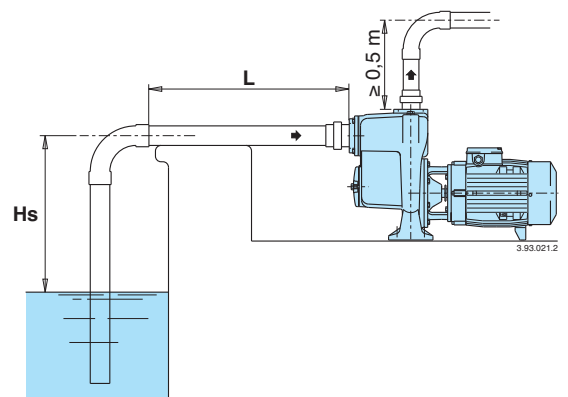



Characteristic curves $n \approx 2900$ rpm

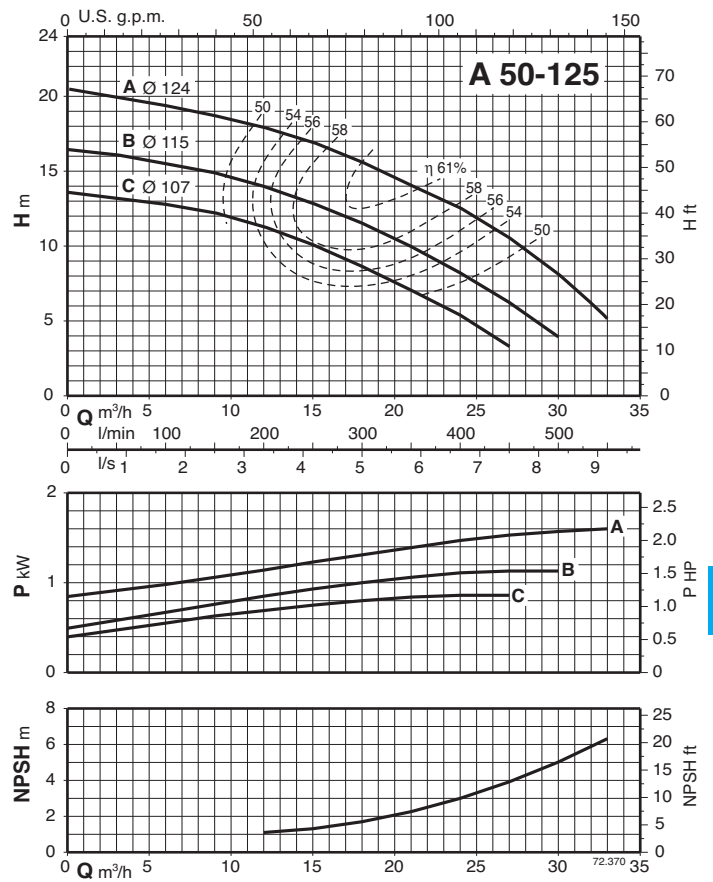
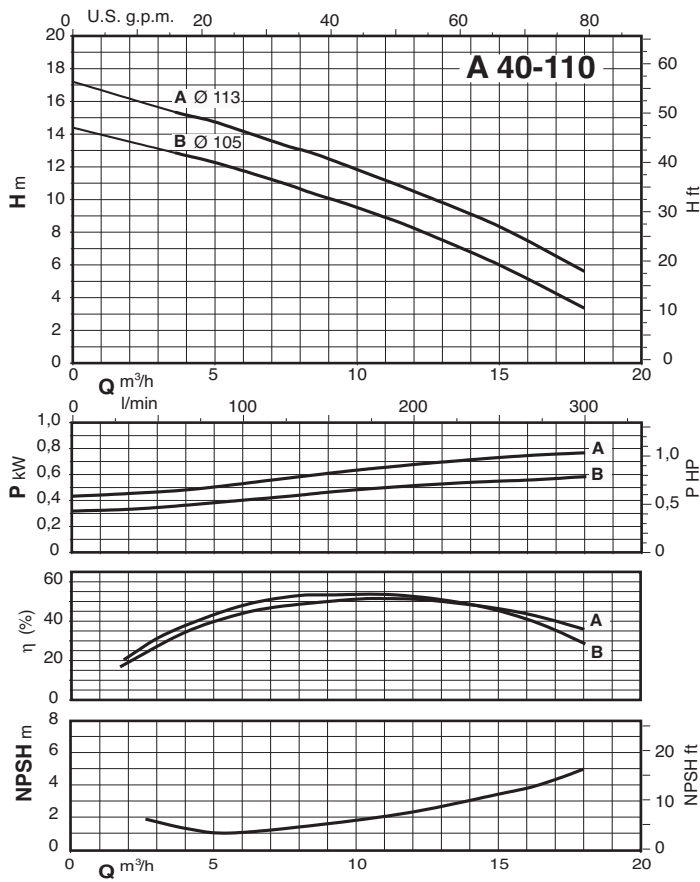

17

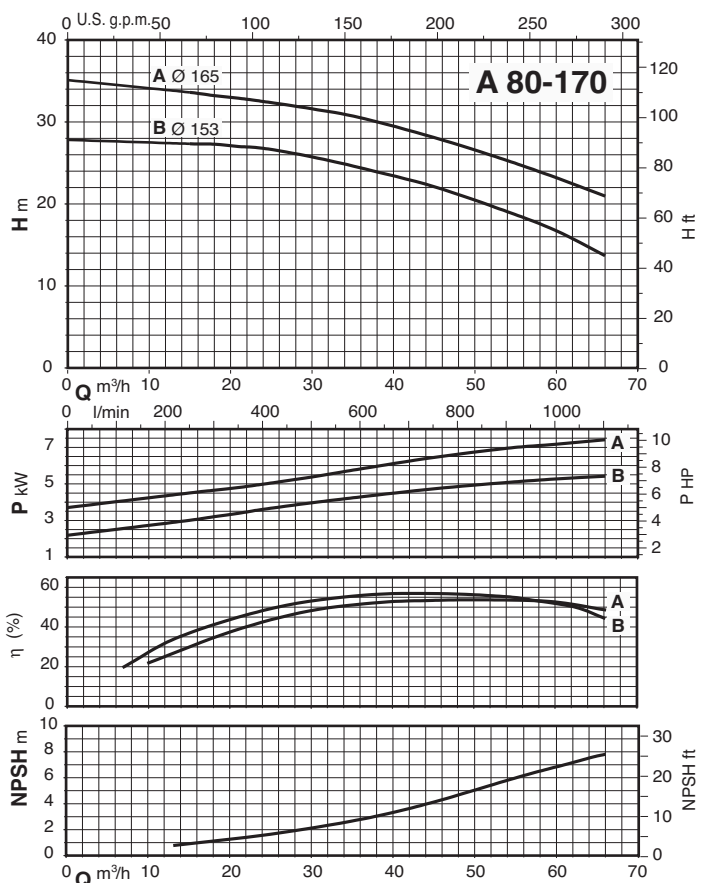
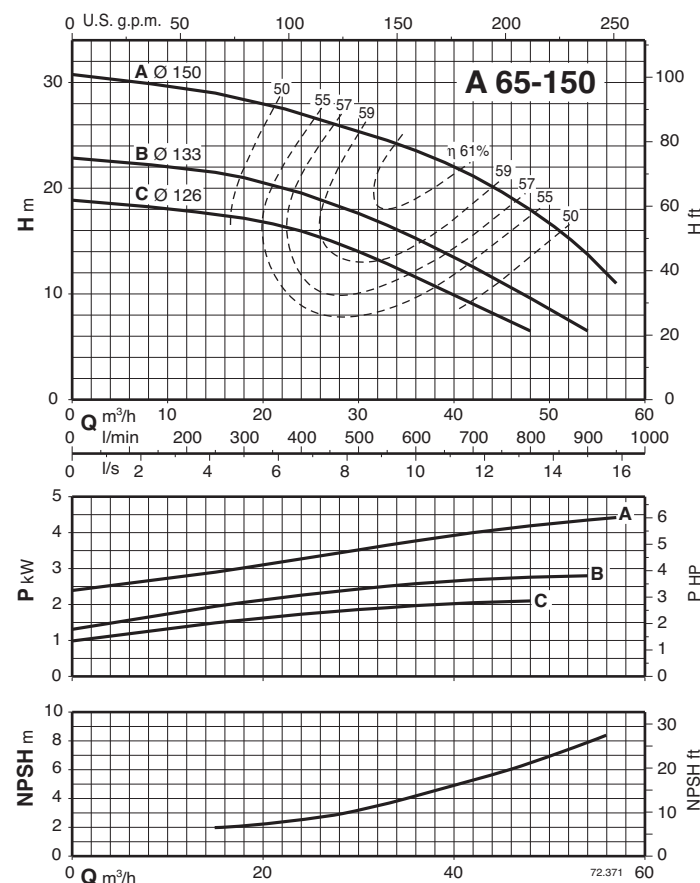



Dimensions and weights

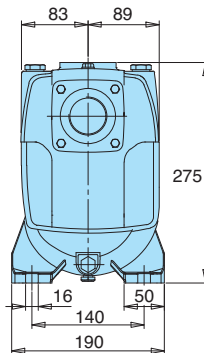
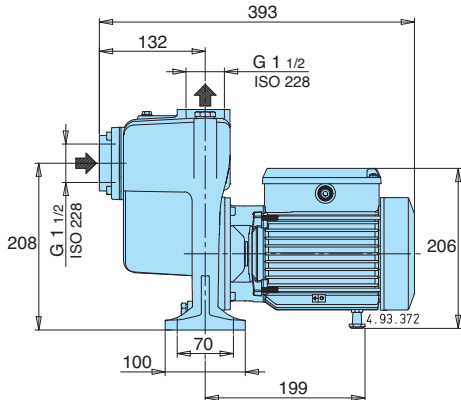

	kg
A 40-110A/A	19,8
AM 40-110A/A	20,8
A 40-110B/A	18,9
AM 40-110B/A	19,8
B-A 40-110A/A	22,5
B-AM 40-110A/A	23,5
B-A 40-110B/A	21,6
B-AM 40-110B/A	22,5

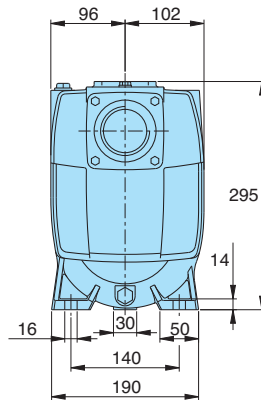
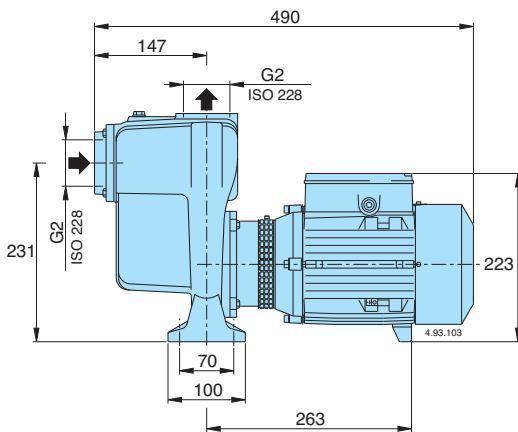

	kg
A 50-125AE	29,9
AM 50-125AE	31
A 50-125BE	28
AM 50-125BE	29,1
A 50-125CE	26,9
AM 50-125CE	27,8
B-A 50-125AE	33,6
B-AM 50-125AE	33,6
B-A 50-125BE	31
B-AM 50-125BE	32,6
B-A 50-125CE	29,6
B-AM 50-125CE	30,6

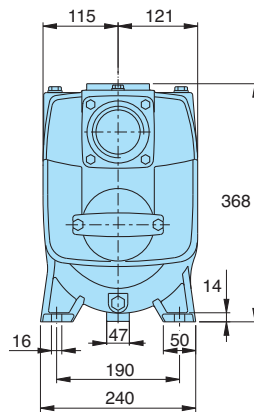
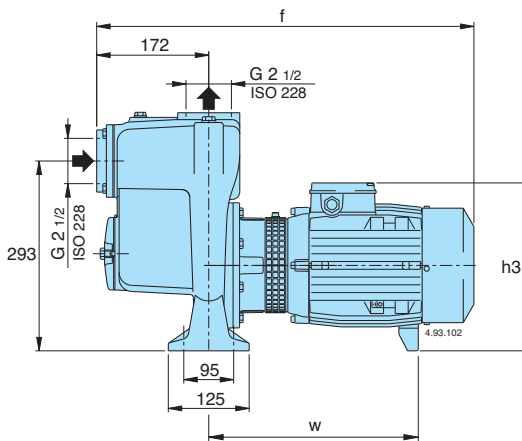

TYPE	mm			kg
	f	h3	w	
A 65-150C/B	595	270	324	56,7
B-A 65-150C/A	583	260	319	50,4
A 65-150B/B	595	270	324	57
B-A 65-150B/A	595	270	324	58,5
A 65-150A/B	595	270	324	58,5
B-A 65-150A/A	595	270	324	60

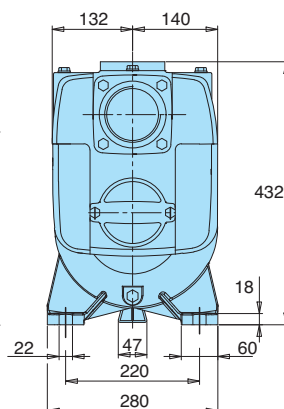
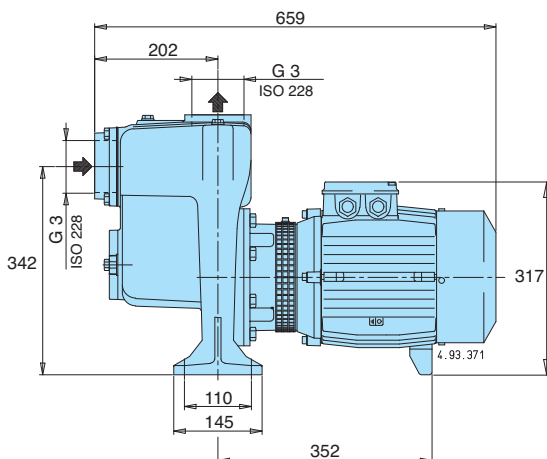

	kg
A 80-170A/A	85,8
A 80-170B/A	80,3
B-A 80-170A/A	95,6
B-A 80-170B/A	90,1

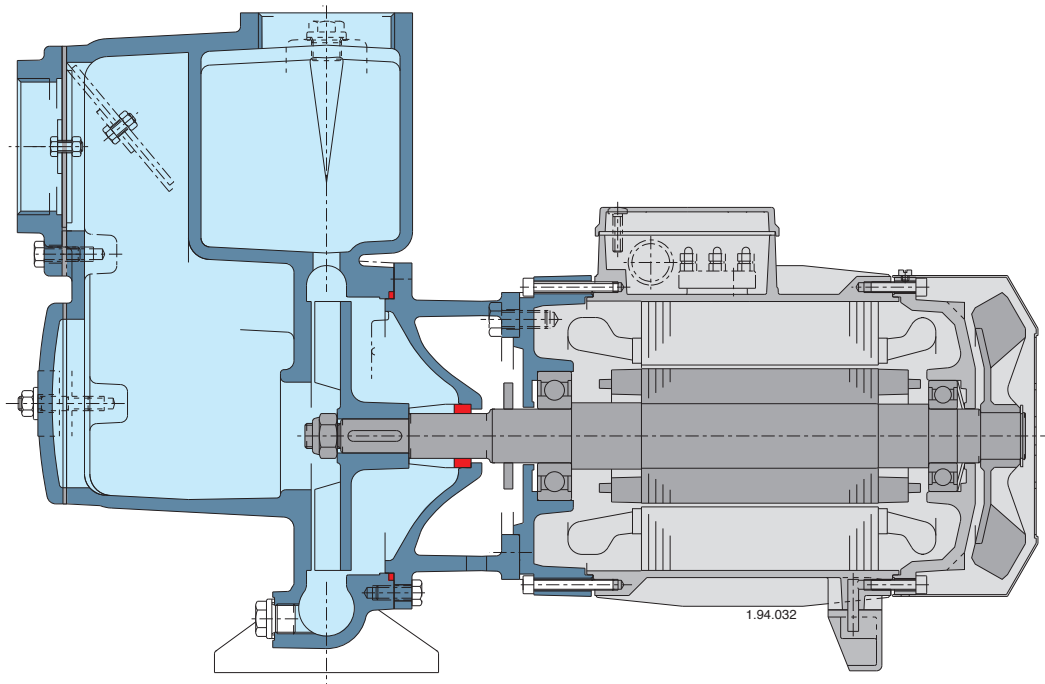
Features**Fast self priming**

An integrated non-return valve and the design of the pump casing ensures rapid priming, once the pump body has been filled with water.

Flexible

The option to choose between cast iron and bronze materials for the hydraulic parts in contact with the pumped liquid allows A series pumps to be selected for use with different types of liquids.

Solid parts

The open impeller allows for the passage of suspended solids in pumped liquid.

Exclusive design

An innovative, patented guard prevents contact with rotating parts, providing protection to the end user whilst allowing for inspection of the mechanical seal.

Reliable

The bearing and shaft are designed to ensure the reduction of the stress, providing high reliability under all operating conditions.