



PERFORMANCE RANGE

- Flow rate up to **90 l/min** (5.4 m³/h)
- Head up to **100 m**

APPLICATION LIMITS

- Manometric suction lift up to **8 m**
- Liquid temperature between **-10 °C** and **+90 °C**
- Ambient temperature between **-10 °C** and **+40 °C** (+45 °C for PQ 60, PQ 60-Bs)
- Max. working pressure:
 - **6.5 bar** for PQ 60-65
 - **10 bar** for PQ 70-80-81-90-100-200-300
- Continuous service **S1**

CONSTRUCTION AND SAFETY STANDARDS

EN 60034-1
IEC 60034-1
CEI 2-3



CERTIFICATIONS



AN30



PIPOMTECT-168

INSTALLATION AND USE

Suitable for use with clean water that does not contain abrasive particles and liquids that are not chemically aggressive towards the materials from which the pump is made.

The hydraulic characteristics of these pumps, coupled with their compactness, makes them suitable for use in both domestic and industrial applications.

The pump should be installed in an enclosed environment, or at least sheltered from inclement weather.

PATENTS - TRADE MARKS - MODELS

- Registered model [®]PQm60 n° 0001520591
- Motor bracket: patent n° IT1243605
- Registered Community Design n° 002146548

OPTIONALS AVAILABLE ON REQUEST

- Special mechanical seal
- EN 10088-3 - 1.4401 (AISI 316) stainless steel motor shaft
- Other voltages or 60 Hz frequency
- IP X5 class protection for PQ 70-80-90-100-200-300

GUARANTEE

2 years subject to terms and conditions

CHARACTERISTIC CURVES AND PERFORMANCE DATA

50 Hz n= 2900 1/min HS= 0 m

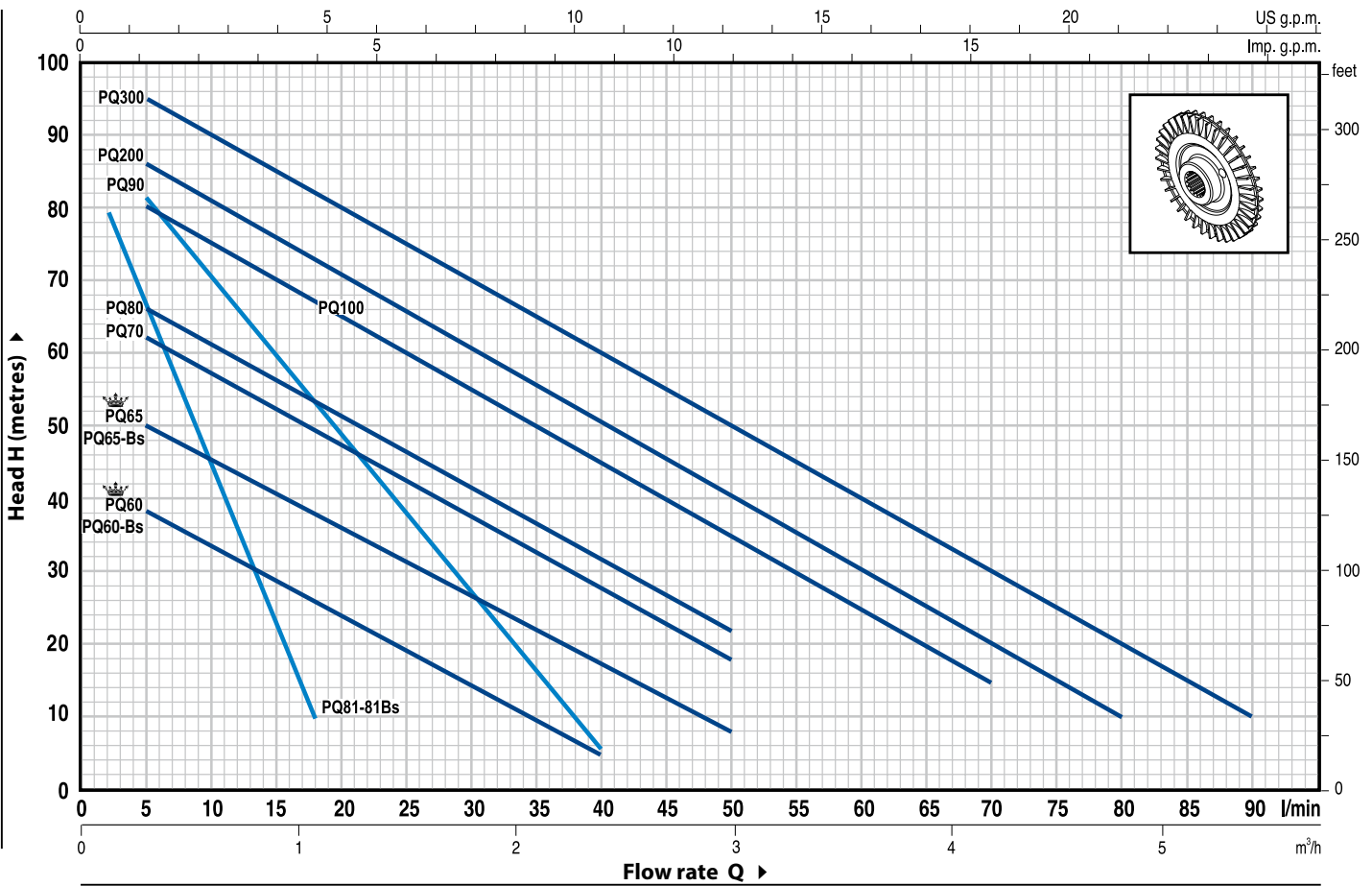

MODEL		POWER		Q	Flow rate																
Single-phase	Three-phase	kW	HP		m³/h	0	0.3	0.6	0.9	1.2	1.5	1.8	2.1	2.4	3.0	3.6	4.2	4.8	5.4		
				l/min	0	5	10	15	20	25	30	35	40	50	60	70	80	90			
PQm 60®	PQ 60®	0.37	0.50	H metres	40	38	33.5	29	24	19.5	15	10	5								
PQm 65	PQ 65	0.50	0.70		55	50	45.5	40.5	36	31	27	22	17	8							
PQm 70	PQ 70	0.60	0.85		65	62	57	52	47	42	37	32	27	18							
PQm 80	PQ 80	0.75	1		70	66	61	56	51	46	41	36.5	31	22							
PQm 90	PQ 90	0.75	1		90	82	71	60	49	38	27	17	5								
PQm 100	PQ 100	1.1	1.5		85	80	75	70	65	60	55	50	45	35	25	15					
PQm 200	PQ 200	1.5	2		90	86	81	76	71	65.5	60	55	50	40	30	20	10				
-	PQ 300	2.2	3		100	95	90	85	80	75	70	65	60	50	40	30	20	10			
PQm 60-Bs	PQ 60-Bs	0.37	0.50		40	38	33.5	29	24	19.5	15	10	5								
PQm 65-Bs	PQ 65-Bs	0.50	0.70		55	50	45.5	40.5	36	31	27	22	17	8							

MODEL		POWER		Q	Flow rate										
Single-phase	Three-phase	kW	HP		m³/h	0	0.12	0.24	0.36	0.48	0.60	0.72	0.84	0.96	1.08
				l/min	0	2	4	6	8	10	12	14	16	18	
PQm 81	PQ 81	0.50	0.70	H metres	90	80	71	63	54	45	37	28	19	10	
PQm 81-Bs	PQ 81-Bs	0.50	0.70		90	80	71	63	54	45	37	28	19	10	

Q = Flow rate H = Total manometric head HS = Suction height

Tolerance of characteristic curves in compliance with EN ISO 9906 Grade 3.

➡ Bs= version with brass pump body

POS.	COMPONENT	CONSTRUCTION CHARACTERISTICS					
1	PUMP BODY	Cast iron (brass for PQ-Bs), complete with threaded ports in compliance with ISO 228/1					
2	MOTOR BRACKET	Aluminium with brass insert (patented), reduces the risk of impeller seizure					
3	IMPELLER	Brass, with peripheral radial vanes					
4	MOTOR SHAFT	Stainless steel EN 10088-3 - 1.4104					
5	MECHANICAL SEAL	<i>Pump</i>	<i>Seal</i>	<i>Shaft</i>	<i>Materials</i>		
		<i>Model</i>	<i>Model</i>	<i>Diameter</i>	<i>Stationary ring</i>	<i>Rotational ring</i>	<i>Elastomer</i>
		PQ 60-65	AR-12	Ø 12 mm	Ceramic	Graphite	NBR
		PQ 70-80-81-90 PQ 60Bs-65Bs-81Bs	MG1-12	Ø 12 mm	Silicon carbide	Graphite	NBR
		PQ 100-200-300	FN-14	Ø 14 mm	Graphite	Ceramic	NBR
6	BEARINGS	<i>Pump</i>	<i>Model</i>				
		PQ 60-65-81 PQ 60Bs-65Bs-81Bs	6201 ZZ / 6201 ZZ				
		PQ 70-80-90	6203 ZZ / 6203 ZZ				
		PQ 100-200-300	6204 ZZ / 6204 ZZ				
		7	CAPACITOR	<i>Pump</i>	<i>Capacitance</i>		
<i>Single-phase</i>	<i>(230 V or 240 V)</i>			<i>(110 V)</i>			
PQm 60 - 60Bs	10 µF 450 VL			25 µF 250 VL			
PQm 65 - 65Bs	14 µF 450 VL			25 µF 250 VL			
PQm 70	16 µF 450 VL			60 µF 300 VL			
PQm 80	20 µF 450 VL			60 µF 300 VL			
PQm 81 - 81Bs	14 µF 450 VL			25 µF 250 VL			
PQm 90	20 µF 450 VL			60 µF 300 VL			
PQm 100	31.5 µF 450 VL			60 µF 250 VL			
PQm 200	45 µF 450 VL			80 µF 250 VL			
8	ELECTRIC MOTOR	PQm: single-phase 230 V - 50 Hz with thermal overload protector built-in to the winding.					
		PQ: three-phase 230/400 V - 50 Hz.					
<p>⇒ Pumps fitted with the three-phase motor option offer IE2 (IEC 60034-30) class high performance</p> <ul style="list-style-type: none"> - Insulation: F class. - Protection: IP X4. 							

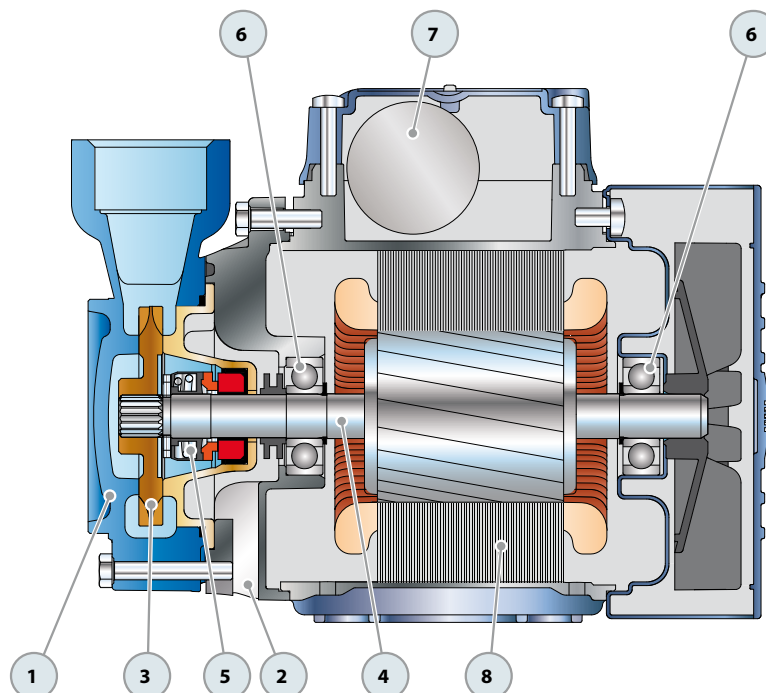

DIMENSIONS AND WEIGHT

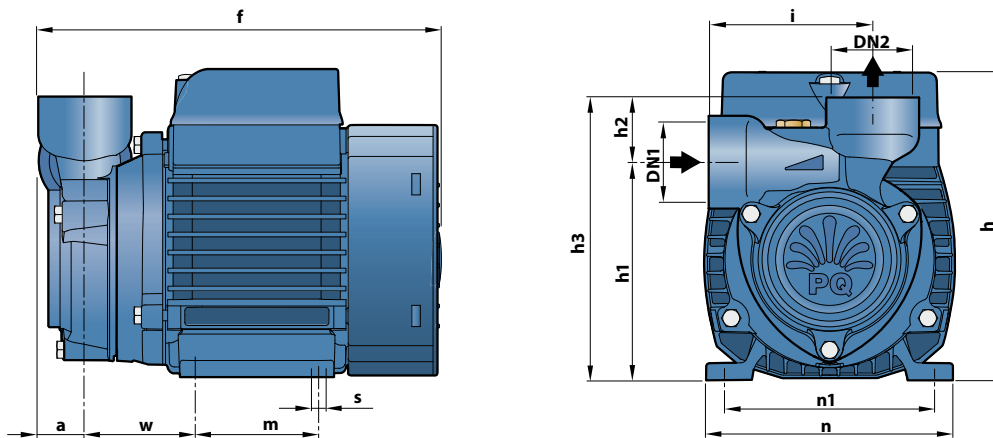

MODEL		PORTS		DIMENSIONS mm												kg		
Single-phase	Three-phase	DN1	DN2	a	f	h	h1	h2	h3	i	m	n	n1	w	s	1~	3~	
👑 PQm 60°	👑 PQ 60°	1"	1"	22	190	145	101	30	131	76	55	118	93-100	53	7	5.1	5.1	
PQm 60-Bs	PQ 60-Bs				216	152	113		143	78	80	120	100			6.4	5.9	
👑 PQm 65	👑 PQ 65				216	152	108		138	76	80	120	100			6.7	6.2	
PQm 65-Bs	PQ 65-Bs				255	180	121		151	83	90	138	112			62	9.7	9.0
PQm 70	PQ 70				255	180	121		151	83	90	138	112			62	9.7	9.0
PQm 80	PQ 80				255	180	121		151	83	90	138	112			62	9.7	9.0
PQm 81	PQ 81	½"	½"	18	214	152	119	22	141	71	80	120	100	56	6.6	6.2		
PQm 81-Bs	PQ 81-Bs				214	152	119		141	71	80	120	100	56	6.5	6.1		
PQm 90	PQ 90	¾"	¾"	22	255	180	126	27	153	84	90	138	112	62	9.9	8.8		
PQm 100	PQ 100				255	180	126		153	84	90	138	112	62	14.1	12.2		
PQm 200	PQ 200	1"	1"	25	318	212	140	30	170	89	100	164	125	85	9	15.2	14.1	
-	PQ 300				318	212	140		170	89	100	164	125	85	9	-	15.2	

ABSORPTION

MODEL	VOLTAGE (single-phase)		
	230 V	240 V	110 V
Single-phase	230 V	240 V	110 V
👑 PQm 60° – PQm 60-Bs	2.6 A	2.4 A	5.2 A
👑 PQm 65 – PQm 65-Bs	3.7 A	3.4 A	7.4 A
PQm 70	5.2 A	4.8 A	10.8 A
PQm 80	5.2 A	4.8 A	10.8 A
PQm 81 – PQm 81-Bs	3.4 A	2.7 A	5.8 A
PQm 90	5.6 A	5.1 A	11.5 A
PQm 100	9.0 A	8.2 A	18.0 A
PQm 200	12.0 A	11.0 A	24.0 A

MODEL	VOLTAGE (three-phase)				
	230 V	400 V	690 V	240 V	415 V
Three-phase	230 V	400 V	690 V	240 V	415 V
👑 PQ 60° – PQ 60-Bs	2.0 A	1.15 A	-	1.9 A	1.1 A
👑 PQ 65 – PQ 65-Bs	3.0 A	1.7 A	-	2.8 A	1.6 A
PQ 70	3.8 A	2.2 A	-	3.3 A	1.9 A
PQ 80	3.8 A	2.2 A	-	3.3 A	1.9 A
PQ 81 – PQ 81-Bs	2.2 A	1.3 A	-	2.0 A	1.15 A
PQ 90	4.2 A	2.4 A	-	3.8 A	2.2 A
PQ 100	6.3 A	3.6 A	2.05 A	5.7 A	3.3 A
PQ 200	7.6 A	4.4 A	2.5 A	7.0 A	4.0 A
PQ 300	9.3 A	5.4 A	3.15 A	8.7 A	5.0 A

PALLETIZATION

MODEL		GROUPAGE				CONTAINER			
Single-phase	Three-phase	n° pumps	H (mm)	kg		n° pumps	H (mm)	kg	
				1~	3~			1~	3~
👑 PQm 60°	👑 PQ 60°	252	1239	1309	1309	324	1563	1676	1676
PQm 60-Bs	PQ 60-Bs	238	1240	1309	1309	306	1563	1676	1676
👑 PQm 65	👑 PQ 65	216	1484	1407	1299	270	1790	1752	1617
PQm 65-Bs	PQ 65-Bs	216	1484	1471	1363	243	1625	1652	1531
PQm 70	PQ 70	102	1280	1013	942	170	2040	1673	1554
PQm 80	PQ 80	102	1280	1013	942	170	2040	1673	1554
PQm 81	PQ 81	216	1484	1450	1363	270	1790	1806	1698
PQm 81-Bs	PQ 81-Bs	216	1484	1428	1342	270	1790	1779	1671
PQm 90	PQ 90	102	1280	1034	922	170	2040	1707	1520
PQm 100	PQ 100	72	1510	1040	900	96	1970	1380	1190
PQm 200	PQ 200	72	1510	1120	1040	96	1970	1480	1380
-	PQ 300	72	1510	-	1120	96	1970	-	1480

