

# GRF



## Impeller with grinder system



All product images are indicative only

### General characteristics

Impeller with grinder system	
motor power	1,1 ÷ 1,5 kW
poles	2
discharge	GAS 1½"-DN32 horizontal
free passage	-
max flow rate	6.4 l/s
max head	23 m

### Electromechanical assembly

Electromechanical assembly in GJL-250 cast iron, for submerged operation. Seal set comprising 2 (two) silicon carbide mechanical seals assembled opposing in inspectable oil sump. Ecological dry motor. Series with explosion-proof ATEX certification.

### Applications

Designed specifically for use where there are traces of flammable liquids or in potentially explosive atmospheres, the GRF is especially recommended for wastewaters containing filaments or fibres, and unstrained civil and industrial wastewaters in general.

### Construction materials

Case	Cast iron EN-GJL 250
Impeller	Cast iron EN-GJL-250
Nuts and bolts	Stainless steel - Class A2-70
Standard gasket	Rubber - NBR - VITON
Cutter material	Chromium steel - X102 CrMo17 KU
Cutting disk material	Chromium steel - X102 CrMo17 KU
Shaft	Stainless steel - AISI 420
Paint type	Ecological bicomponent epoxy (medium thickness 150 µm)
Set of standard mechanical seals	Two silicon carbide mechanical seals (2SiC)

### Operating limits

Maximum operating temperature	40 °C
PH of treated fluid	6 ÷ 14
Viscosity of treated fluid	1 mm <sup>2</sup> /s
Maximum immersion depth	20 m
Density of treated fluid	1 Kg/dm <sup>3</sup>
Maximum acoustic pressure	70 dB
max starts per hour	30



CE 0496 Ex II 2GD Ex db k c IIB T4 Ex tb IIIC T135°C IP68

Models with ATEX certification, suitable for installation in the presence of potentially explosive gases, powders and liquids



**Handle/Cable gland**

Cast iron lifting and carrying handle. The GAS thread ring-nut can be removed to fix a rigid or flexible duct to the cable gland to protect the power supply cable.

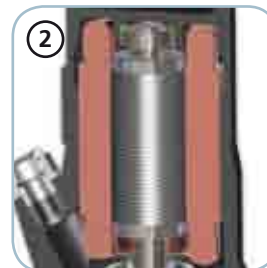

**Motor**

Ecological dry motor with thermal protections.



**Mechanical seals**

Two silicon carbide (SiC) mechanical seals in oil sump.



**Oil sump**

Large oil sump to guarantee longer mechanical seal lifetime.



**Grinder system**

Grinder system comprising a revolving cutter and a plate with holes with sharpened edges that fine-chops filaments, preventing fouling of the impeller.

Up to 69.000 cuts per minute



**Discharge**

Threaded, flanged discharge for the maximum ease of installation.

# GRF

## Models with horizontal GAS 1½" threaded - DN32 PN6 flanged discharge - 2 poles

### Performances

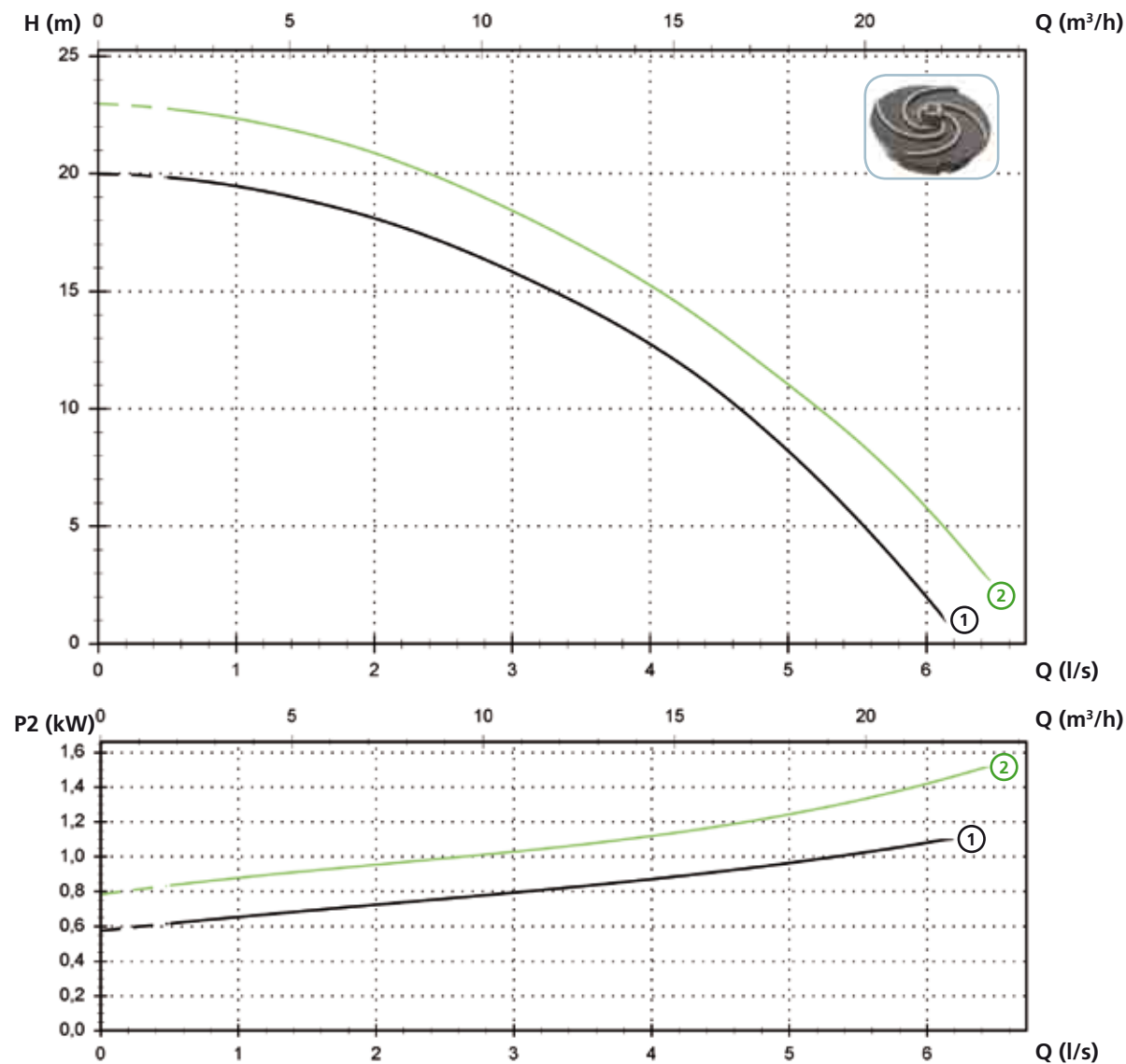

### Technical data

	V	Phases	P1 (kW)	P2 (kW)	A	Rpm	Start	Ø	Free passage	
①	GRF 150/2/G40H A1CM/50	230	1	1.6	1.1	7.2	2900	Dir	G 1½"-DN32 PN6	-
②	GRF 200/2/G40H A1CM/50	230	1	2.2	1.5	9.8	2900	Dir	G 1½"-DN32 PN6	-
	V	Phases	P1 (kW)	P2 (kW)	A	Rpm	Start	Ø	Free passage	
①	GRF 150/2/G40H A1CT/50	400	3	1.7	1.1	2.9	2900	Dir	G 1½"-DN32 PN6	-
②	GRF 200/2/G40H A1CT/50	400	3	2.1	1.5	3.7	2900	Dir	G 1½"-DN32 PN6	-

**Versions available**

(Key to versions on page 16)

	Electrical variants											Cooling				Mechanical seals				
	N A E	T	T C	T C D	T C D T	T C D G T	T C G	T C S T	T C S G T	T S	T R	T R G	N	CC	FT	C G F T	2SIC	SICM	SICAL	2SICAL
GRF 150/2/G40H A1CM/50				●								●					●			
GRF 200/2/G40H A1CM/50				●								●					●			
GRF 150/2/G40H A1CT/50	●											●					●			
GRF 200/2/G40H A1CT/50	●											●					●			

NOTE FOR SINGLE PHASE PUMPS: thermal protections into the winding have to be connected to the electrical panel. Capacitor supplied but not connected to the pump cable. The use of an electrical panel as circuit breaker housing is mandatory. For installation please see use and maintenance instructions booklet.

**Overall dimensions and weights**

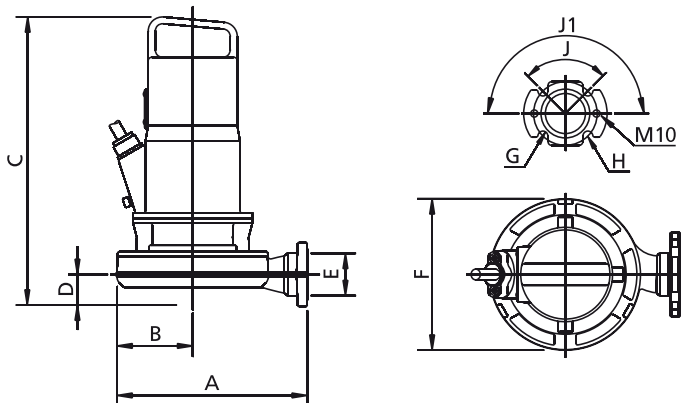

	A	B	C	D	E	F	G	H	J	J1	kg
GRF 150/2/G40H A1CM(T)/50	265	105	405	45	G 1½"	215	14	90	90°	180°	32
GRF 200/2/G40H A1CM(T)/50	265	105	405	45	G 1½"	215	14	90	90°	180°	34

Dimensions in mm

All weights and dimensions are indicative only

**Packaging dimension**

	A	B	C
GRF 150/2/G40H A1CM(T)/50	580	310	310
GRF 200/2/G40H A1CM(T)/50	580	310	310

Dimension in mm

All weights and dimensions are indicative only

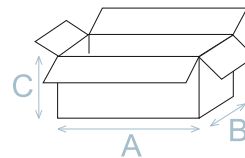

**Installations available**

